

FEDERAL ROAD DISTRICT NO.	STATE	PROJECT NO.	FISCAL YEAR	SHEET NO.	TOTAL SHEETS
5	IND.	STI-94-2()39	1992	41	

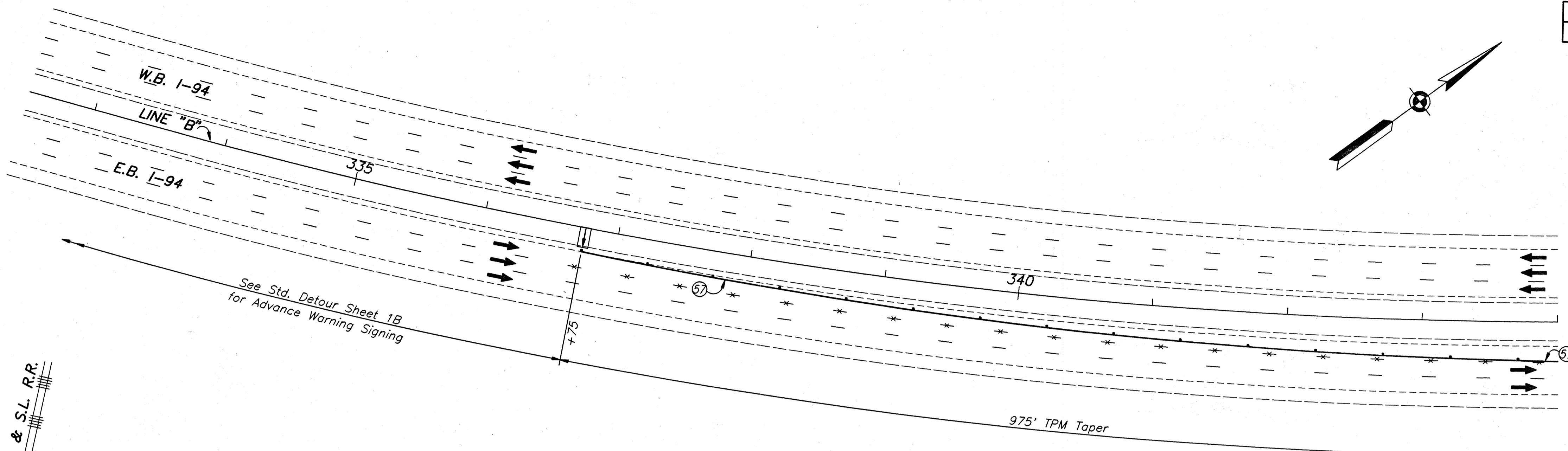
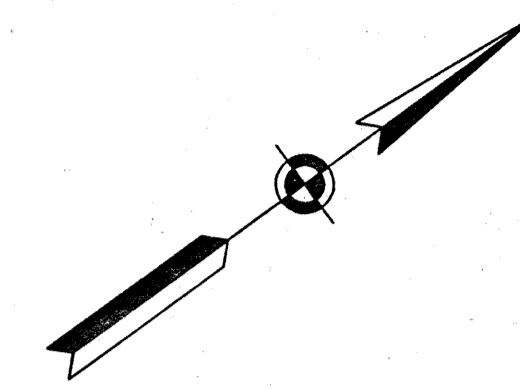

END CONSTRUCTION
XG20-2
60" x 24"

M.Y., C. & S.L. R.R.

BEGIN STI-PROJECT NO. 94-2()39
STA. 350+00 LINE "B"

ROAD CONSTRUCTION AHEAD
XW20-1
48" x 48"

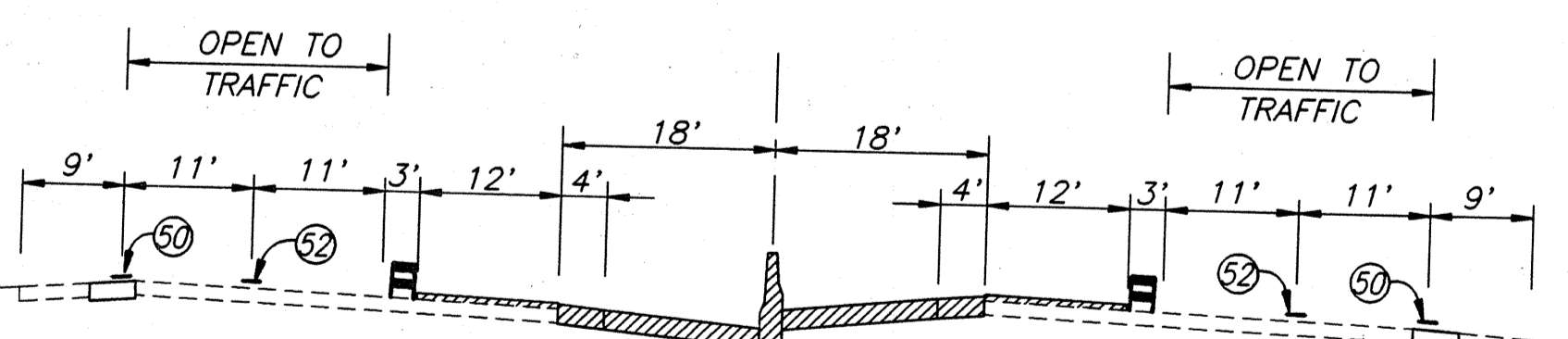
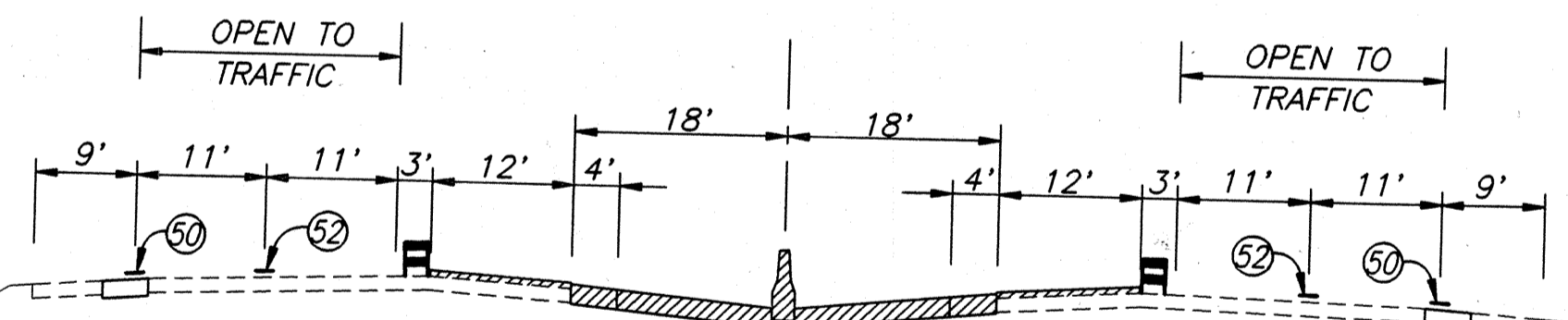
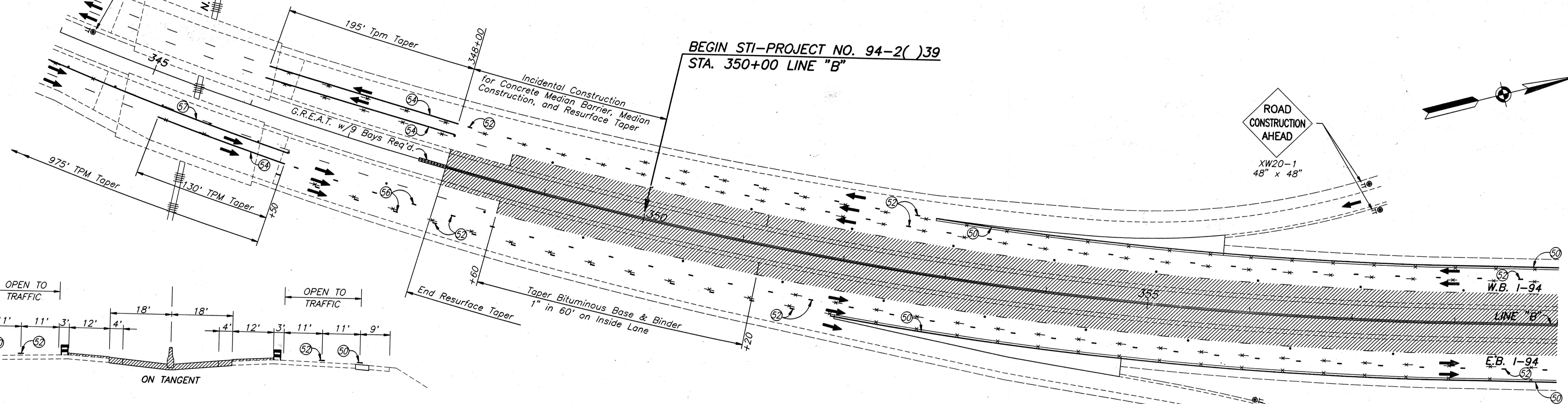
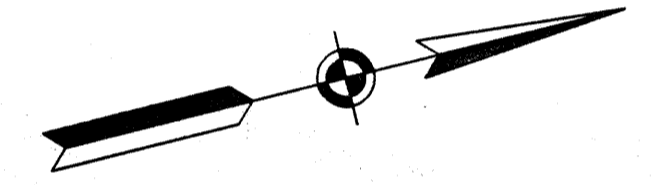

Sta. 348+00 to 511+00 "B"

1. Construct Concrete Median Barrier
2. Construct Inside Shoulder & Median with Full Depth Bituminous Pavement:
220#/Syd. Bituminous Binder 8 or 9, MV on
440#/Syd. Bituminous Base 5, MV on
400#/Syd. Bituminous Base 5C, MV on
400#/Syd. Bituminous Base 5D, MV on
3. Resurface Inside Lane:
165#/Syd. Bituminous Binder 8 or 9, HV on
305#/Syd. Bituminous Base 5, HV

LEGEND

- Section to be Built During Phase II of Construction
- Type II Barricade or Standard Drum
- Typical Sign Standard with Construction Warning Light Type A
- Flashing Arrow Sign
- Pavement Marking Removal
- Temporary Pavement Marking Type II, White, 4 in.
- Temporary Pavement Marking Type II, White, Broken, 5 in. (4' Spaced 40' C. to C.)
- Temporary Pavement Marking Type I, White, 4 in.
- Temporary Pavement Marking Type I, White, Broken, 5 in. (4' Spaced 40' C. to C.)
- Temporary Pavement Marking Type I, Yellow, 4 in.
- Temporary Pavement Marking

END CONSTRUCTION
XG20-2
60" x 24"

NOTE:
1. Remove existing bituminous wedge at all bridges prior to resurfacing.

PHASE II MAINTENANCE OF TRAFFIC DETAILS

Scale: 1"=50'

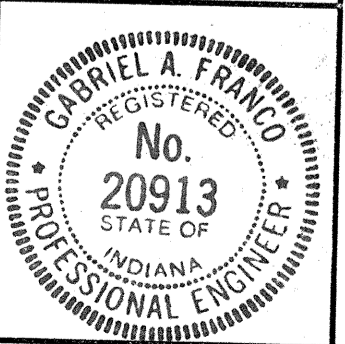

R-20060 2 OF 6

G:\CADD\DWG\101\101\101.DWG

FEDERAL ROAD REGION NO.	STATE	PROJECT NO.	FISCAL YEAR	SHEET NO.	TOTAL SHEETS
5	IND.	571-94-2()39	1992	42	126

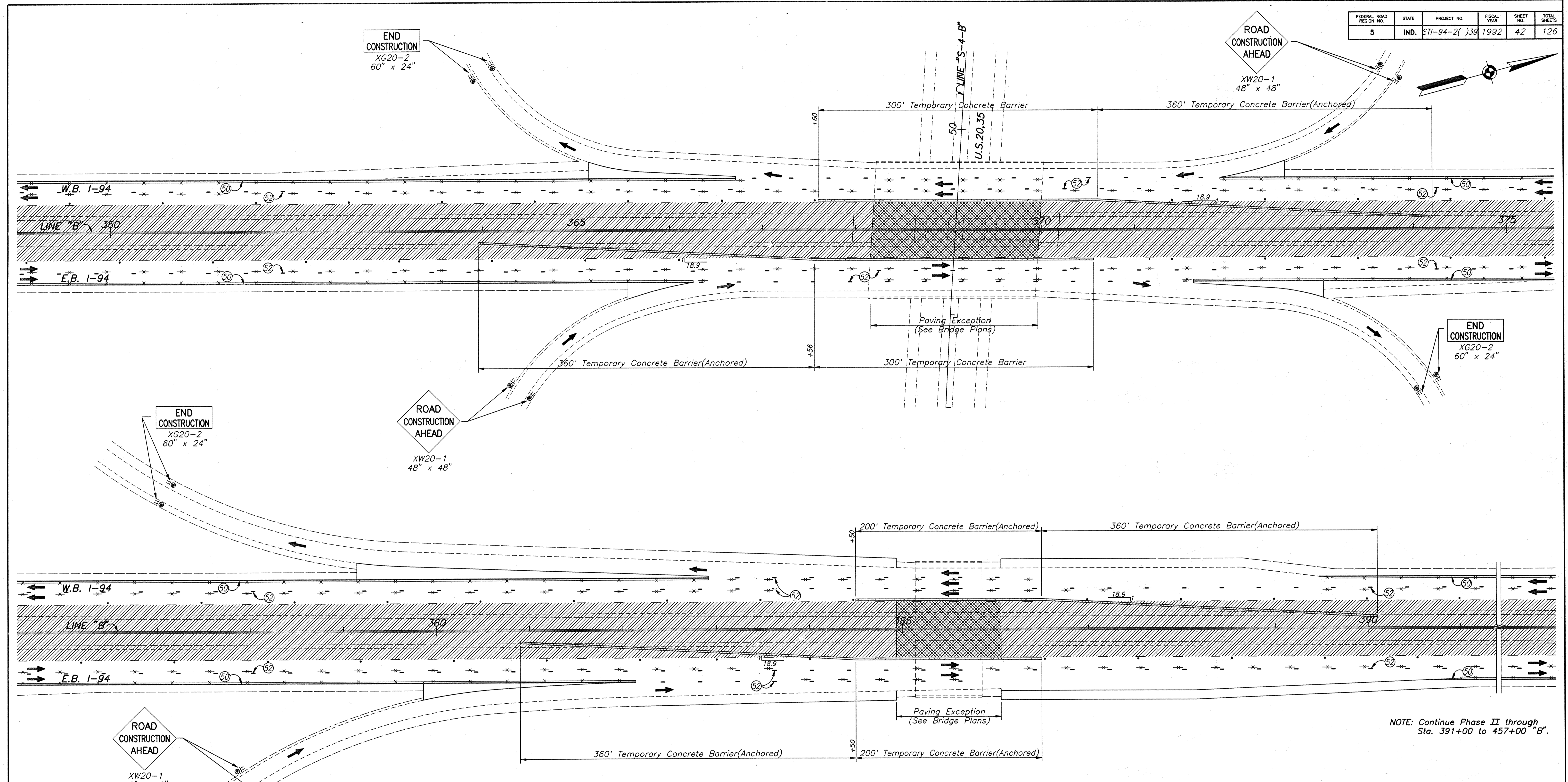

NOTE: Continue Phase II through Sta. 391+00 to 457+00 "B".

- LEGEND**
- Section to be Built During Phase II of Construction (See Detail Sheet No.41)
 - Paving Exception (See Bridge Plans)
 - Type II Barricade or Standard Drum
 - Typical Sign Standard with Construction Warning Light Type A
 - Temporary Concrete Barrier
 - Pavement Marking Removal
 - Temporary Pavement Marking Type II, White, 4 in.
 - Temporary Pavement Marking Type II, White, Broken, 5 in. (4' Spaced 40' C. to C.)

PHASE II MAINTENANCE OF TRAFFIC DETAILS

Scale: 1"=50'

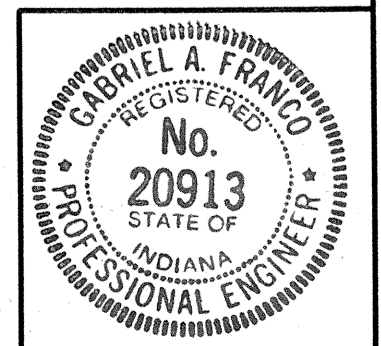

R-20060

G:\CADD\DWG\7017TMO4.DWG

FEDERAL ROAD DISTRICT NO.	STATE	PROJECT NO.	FISCAL YEAR	SHEET NO.	TOTAL SHEETS
5	IND.	STI-94-2()39	1992	43	126

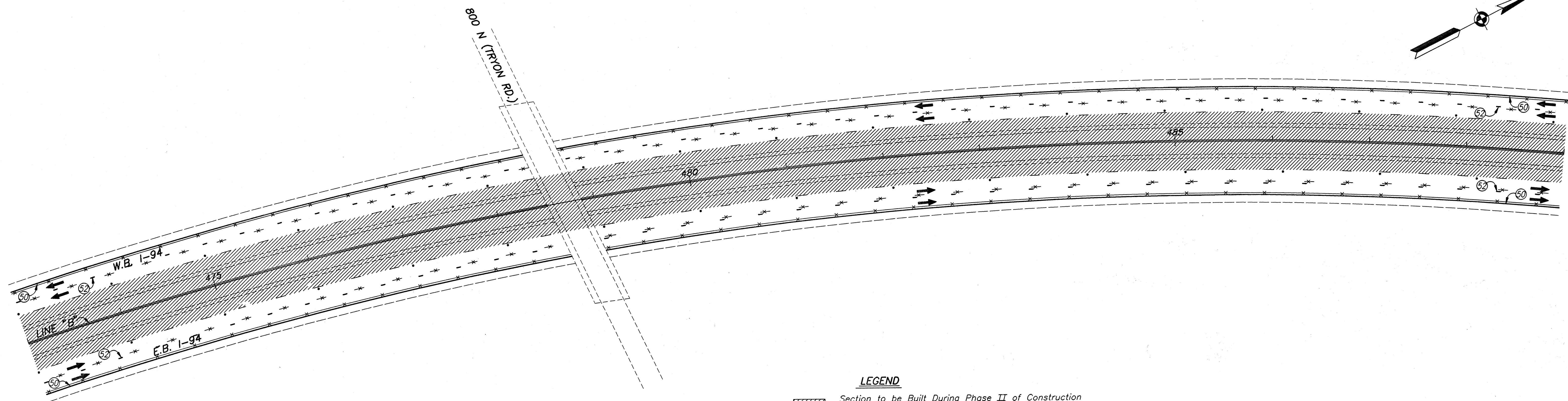
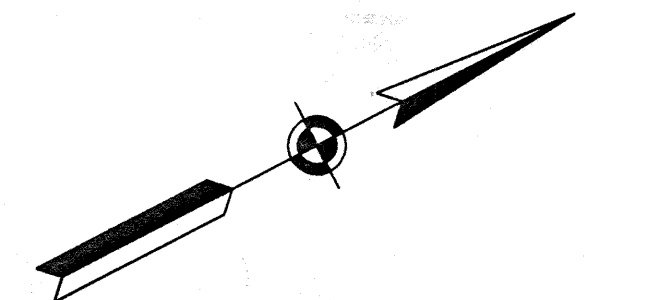
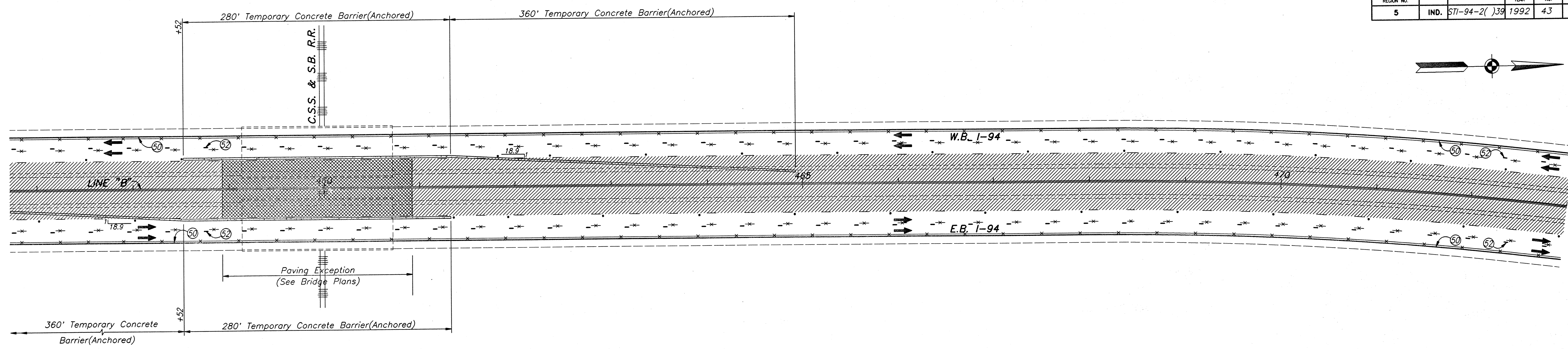

G:\CADD\DWG\70177M05.DWG

- LEGEND**
- Section to be Built During Phase II of Construction (See Detail Sheet No.41)
 - Paving Exception (See Bridge Plans)
 - Type II Barricade or Standard Drum
 - Typical Sign Standard with Construction Warning Light Type A
 - Temporary Concrete Barrier
 - Pavement Marking Removal
 - Temporary Pavement Marking Type II, White, 4 in.
 - Temporary Pavement Marking Type II, White, Broken, 5 in. (4' Spaced 40' C. to C.)

PHASE II MAINTENANCE OF TRAFFIC DETAILS

Scale: 1"=50'



R-20000

Rev 9/14/92
Revised and Replace sh. 44

FEDERAL ROAD REGION NO.	STATE	PROJECT NO.	FISCAL YEAR	SHEET NO.	TOTAL SHEETS
5	IND.	STI-94-2()39	1992	44	126

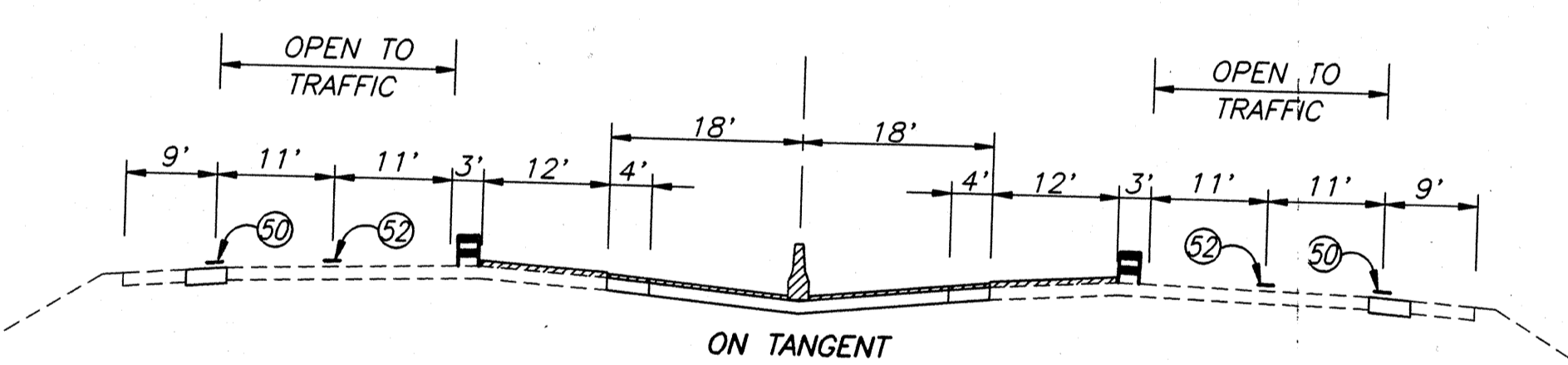
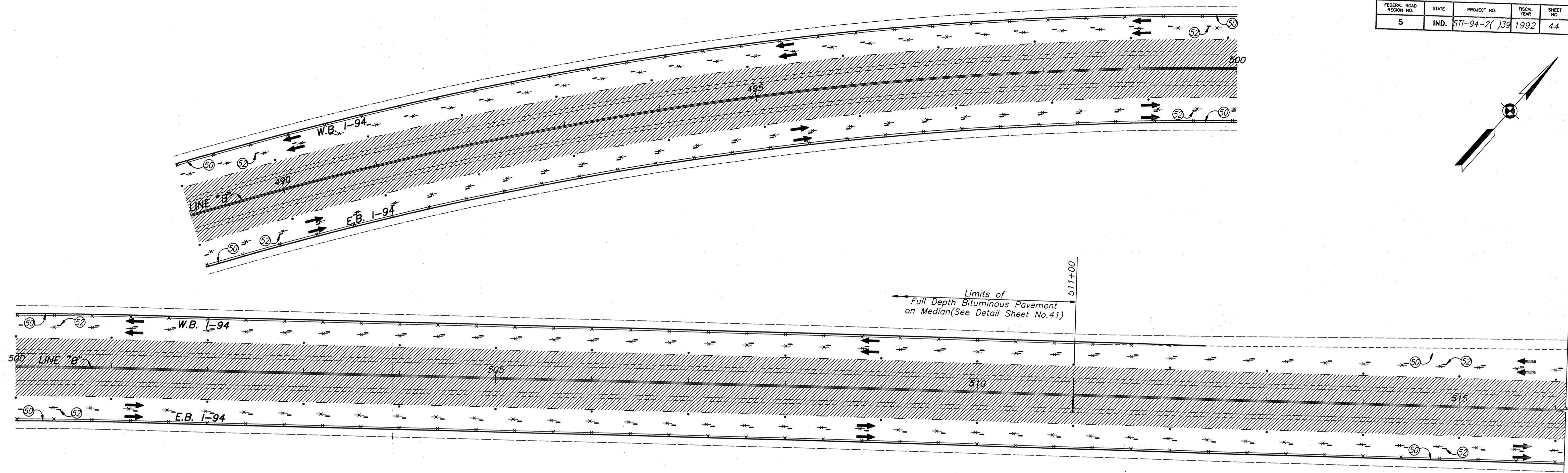
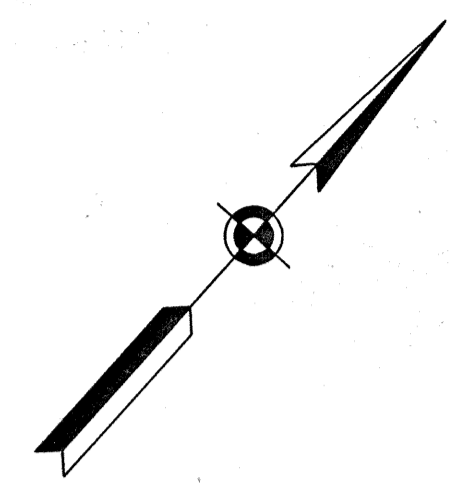

- Sta. 665+00 to 679+18.48 "B"**
1. Construct Concrete Median Barrier
 2. Resurface Median and Inside Shoulder:
165#/Syd. Bituminous Binder 8 or 9, LV on
250#/Syd. Bituminous Base 5, LV
 3. Resurface Inside Lane:
165#/Syd. Bituminous Binder 8 or 9, HV on
305#/Syd. Bituminous Base 5, HV

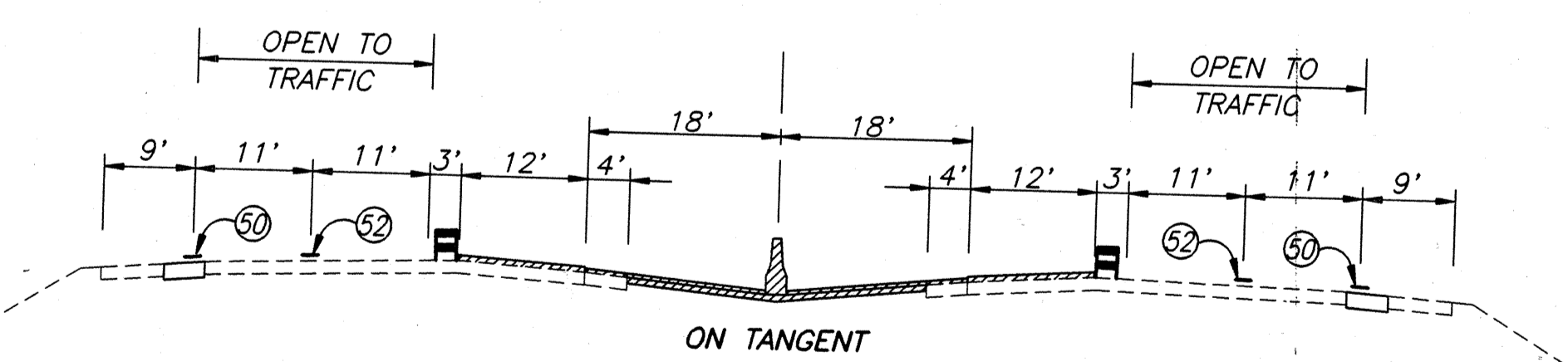

- Sta. 511+00 to 665+00 "B"**
1. Construct Concrete Median Barrier
 2. Construct Median:
165#/Syd. Bituminous Binder 8 or 9, LV on
250#/Syd. Bituminous Base 5, LV on
6" Compacted Aggregate for Base, Type "O" (No.53)
 3. Resurface Median and Inside Shoulder:
165#/Syd. Bituminous Binder 8 or 9, LV on
250#/Syd. Bituminous Base 5, LV
 4. Resurface Inside Lane:
165#/Syd. Bituminous Binder 8 or 9, HV on
305#/Syd. Bituminous Base 5, HV

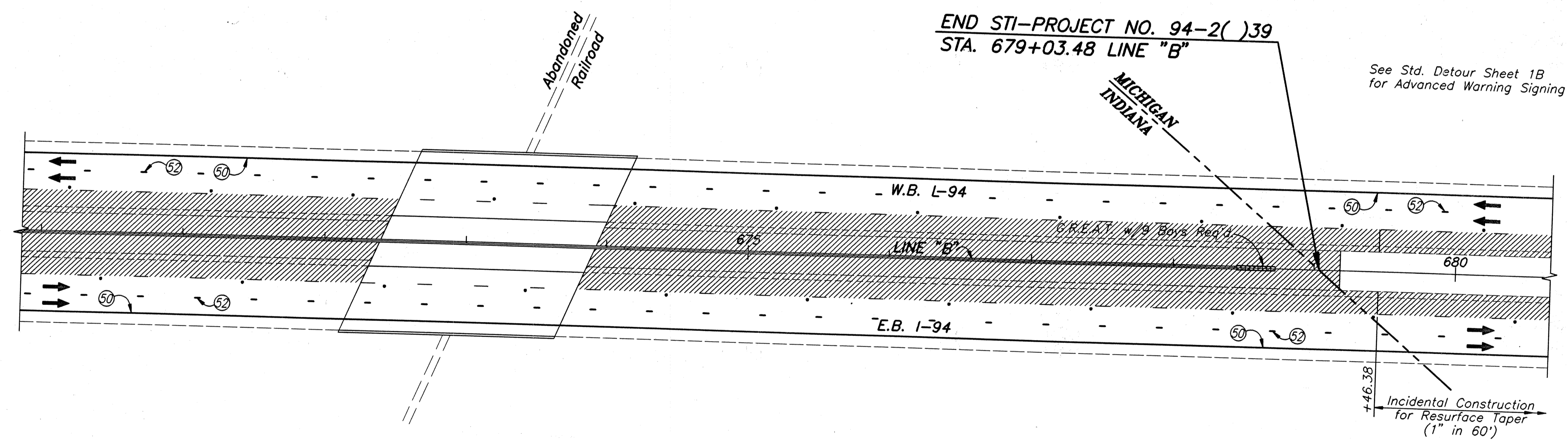

END STI-PROJECT NO. 94-2()39
STA. 679+03.48 LINE "B"

See Std. Detour Sheet 1B
for Advanced Warning Signing

- LEGEND**
- Section to be Built During Phase II Construction
 - Type II Barricade or Standard Drum
 - Pavement Marking Removal
 - Temporary Pavement Marking Type II, White, 4 in.
 - Temporary Pavement Marking Type II, White, Broken, 5 in. (4' Spaced 40' C. to C.)

PHASE II MAINTENANCE OF TRAFFIC DETAILS

Scale: 1"=50'

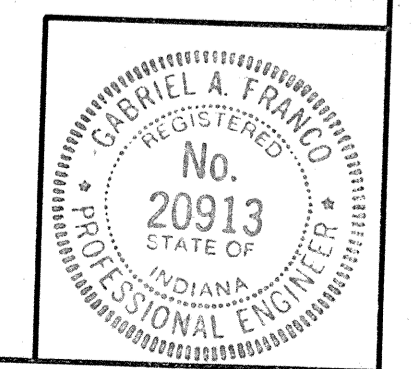

R-20060

G:\CADD\DWG\7017TMO6.DWG

FEDERAL ROAD REGION NO.	STATE	PROJECT NO.	FISCAL YEAR	SHEET NO.	TOTAL SHEETS
5	IND.	STI-94-2()39	1992	45	126

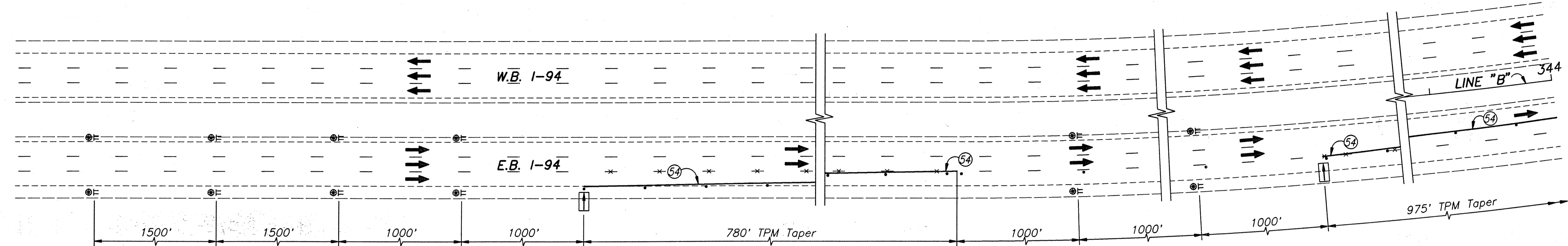

- NOTES:**
- Remove existing bituminous wedge at all bridges prior to resurfacing.
 - Immediately following the movement of traffic to the median and inside lane, base and binder shall be placed on the center, outside and auxiliary lanes from Sta. 348+60 to Sta. 352+00 NB, Sta. 359+70 to Sta. 374+89 SB, Sta. 363+28 to Sta. 378+63 NB, Willow Creek Bridge Approach to 394+40 NB, Willow Creek Bridge Approach to Sta. 391+65 SB to allow all movements at the interchange. The placement of the base and binder shall be done such that closure of the ramps will be for the shortest possible time. (See Special Provisions)
 - After placement of base and binder on the center lane from Sta. 348+60 to Sta. 358+00 NB, closure of the center lane prior to the project limits will not be necessary. Traffic shall be maintained on the inside and center lanes up to Sta. 348+00, then moved to the median and inside lane with a 975' taper.

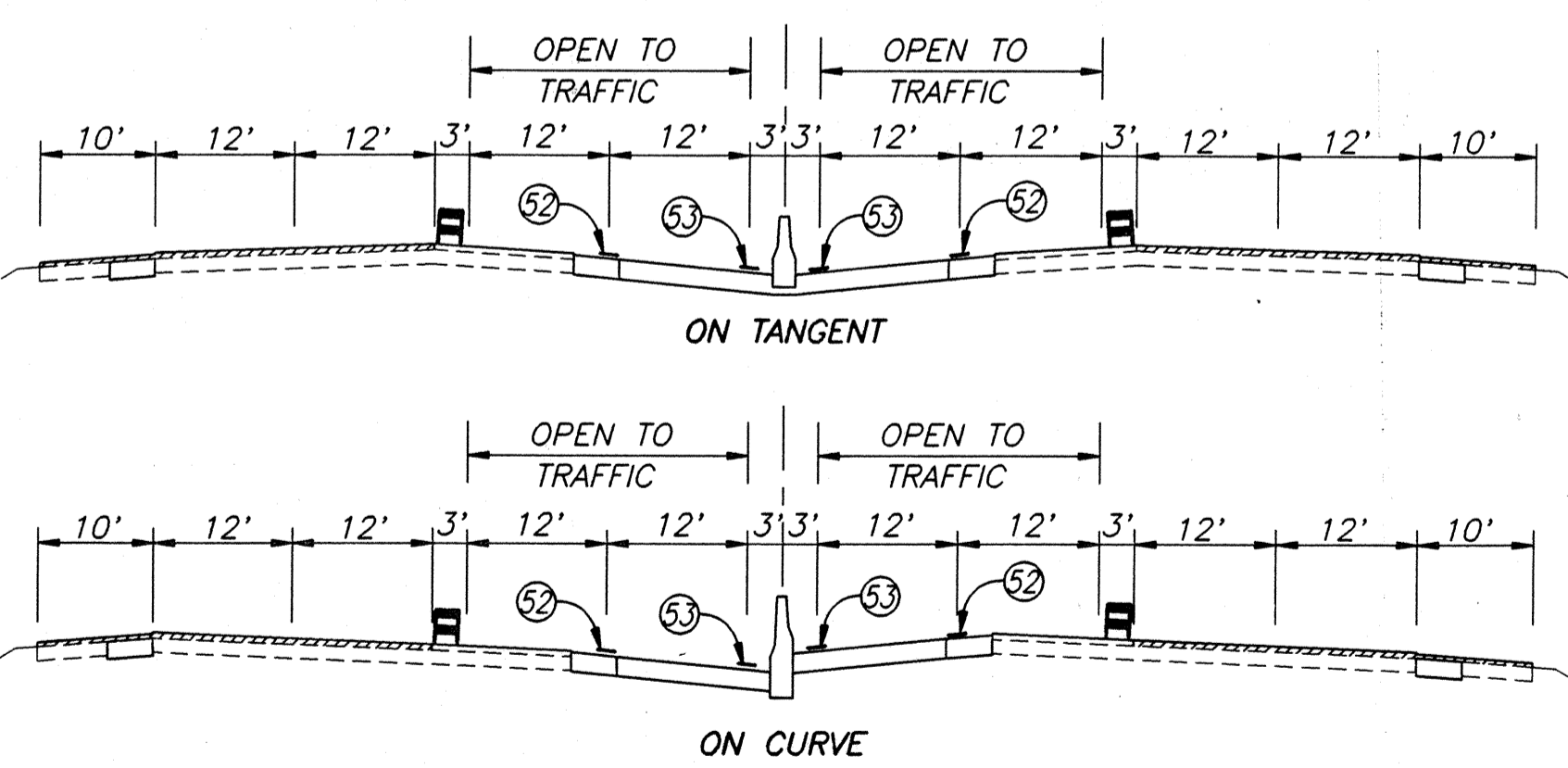
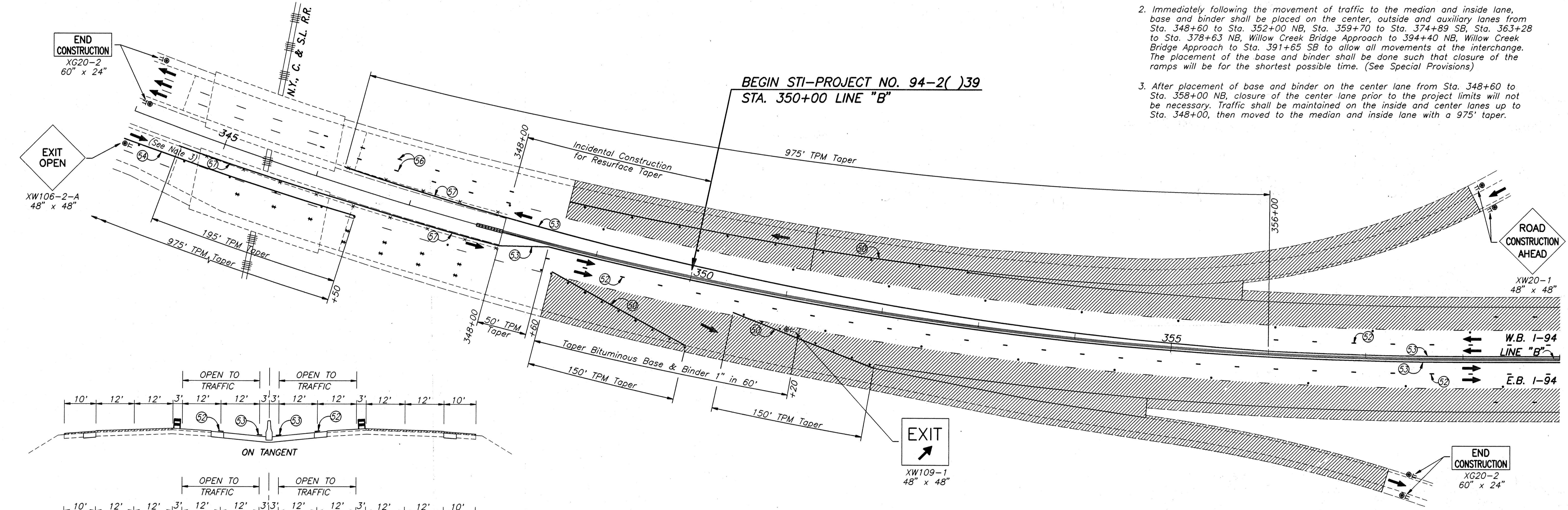

- Sta. 348+00 to 511+00 "B"**
- Resurface Center Lane and Outside Lane:
165#/Syd. Bituminous Binder 8 or 9, HV on
305#/Syd. Bituminous Base 5, HV
 - Resurface Outside Shoulder:
165#/Syd. Bituminous Binder 8 or 9, LV on
250#/Syd. Bituminous Base 5, LV

- LEGEND**
- Section to be Built During Phase III of Construction
 - Type II Barricade or Standard Drum
 - Typical Sign Standard with Construction Warning Light Type A
 - Flashing Arrow Sign
 - Pavement Marking Removal
 - Temporary Pavement Marking Type II, White, 4 in.
 - Temporary Pavement Marking Type II, White, Broken, 5 in. (4' Spaced 40' C. to C.)
 - Temporary Pavement Marking Type II, Yellow, 4 in.
 - Temporary Pavement Marking Type I, White, 4 in.
 - Temporary Pavement Marking Type I, White, Broken, 5 in. (4' Spaced 40' C. to C.)
 - Temporary Pavement Marking Type I, Yellow, 5 in.
 - TPM Temporary Pavement Marking

PHASE III MAINTENANCE OF TRAFFIC DETAILS

Scale: 1"=50'

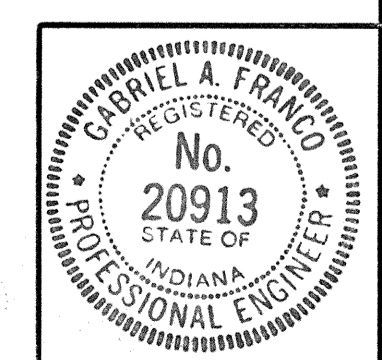

G:\CADD\DWG\70171M07.DWG

FEDERAL ROAD DISTRICT NO.	STATE	PROJECT NO.	FISCAL YEAR	SHEET NO.	TOTAL SHEETS
5	IND.	571-94-2()39	1992	46	126

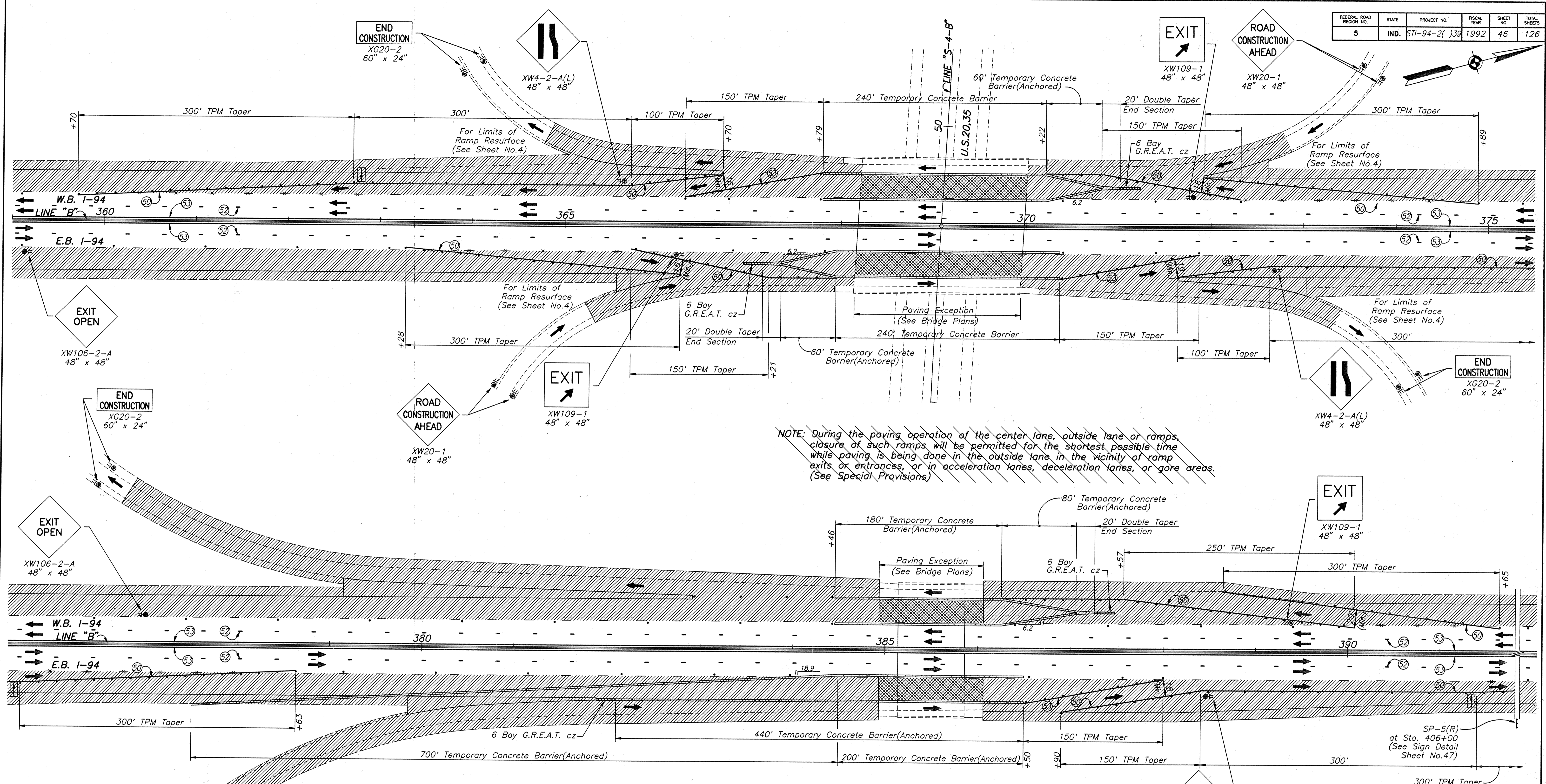

NOTE: During the paving operation of the center lane, outside lane or ramps, closure of such ramps will be permitted for the shortest possible time while paving is being done in the outside lane in the vicinity of ramp exits or entrances, or in acceleration lanes, deceleration lanes, or gore areas. (See Special Provisions)

NOTE: Continue Phase III through Sta. 391+00 to 457+00 "B".

- LEGEND**
- Section to be Built During Phase III of Construction (See Detail Sheet No.45)
 - Paving Exception (See Bridge Plans)
 - Type II Barricade or Standard Drum
 - Construction Sign Type A with Construction Warning Light Type A
 - Flashing Arrow Sign
 - Temporary Concrete Barrier
 - Pavement Marking Removal
 - Temporary Pavement Marking Type II, White, 4 in.
 - Temporary Pavement Marking Type II, White, Broken, 5 in. (4' Spaced 40' C. to C.)
 - Temporary Pavement Marking Type II, Yellow, 4 in.
 - Temporary Pavement Marking

PHASE III MAINTENANCE OF TRAFFIC DETAILS

Scale: 1"=50'

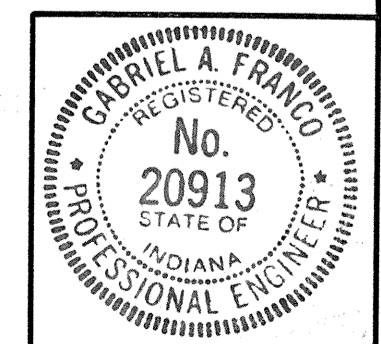

G:\CADD\DWG\70171M08.DWG

FEDERAL ROAD DISTRICT NO.	STATE	PROJECT NO.	FISCAL YEAR	SHEET NO.	TOTAL SHEETS
5	IND.	STI-94-2()39	1992	47	126

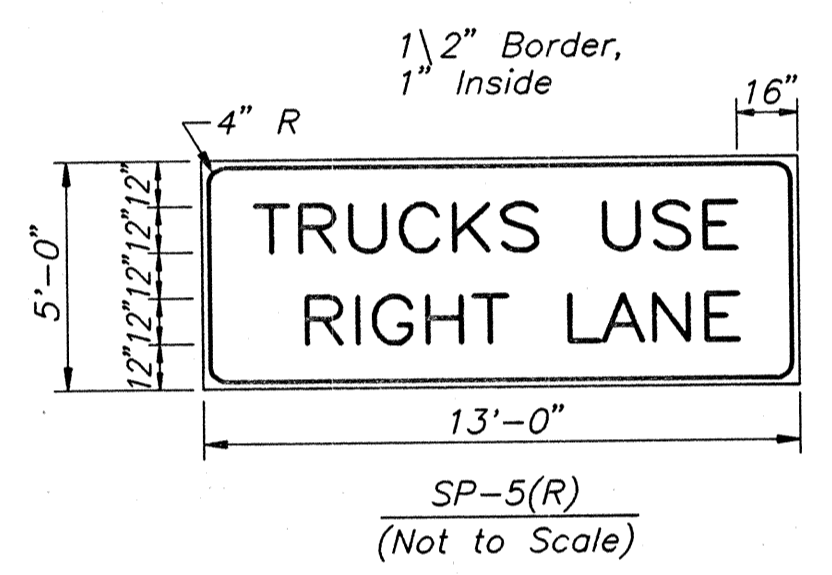
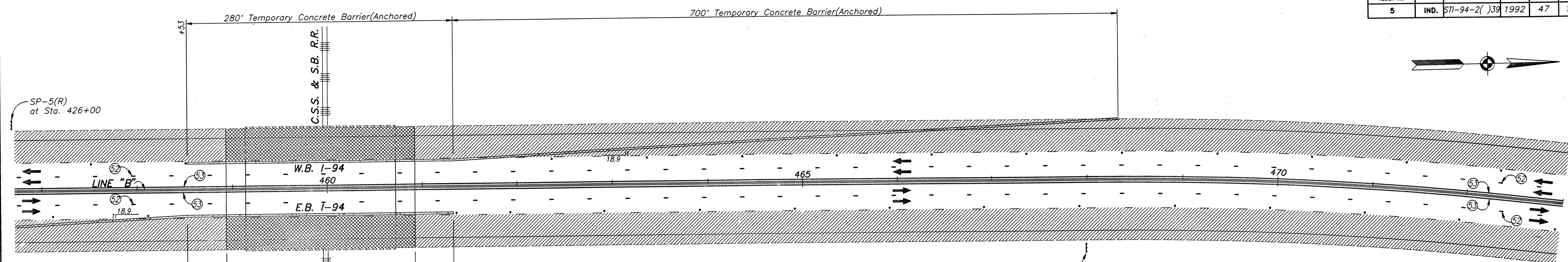

NOTES:

1. All Letters and Borders - Black(Non-Reflective).
2. All Background - Orange(Reflective).
3. Mount Signs on 3-4"x4" Wood Posts with Minimum Spacing of 6'-0".
4. Sign to be paid for as Construction Sign Type A.
5. Location of Sign SP-5(R) shall be as shown on the following Table or as directed:

STATION
406+00 Rt.
426+00 Lt.
468+00 Rt.
489+00 Lt.

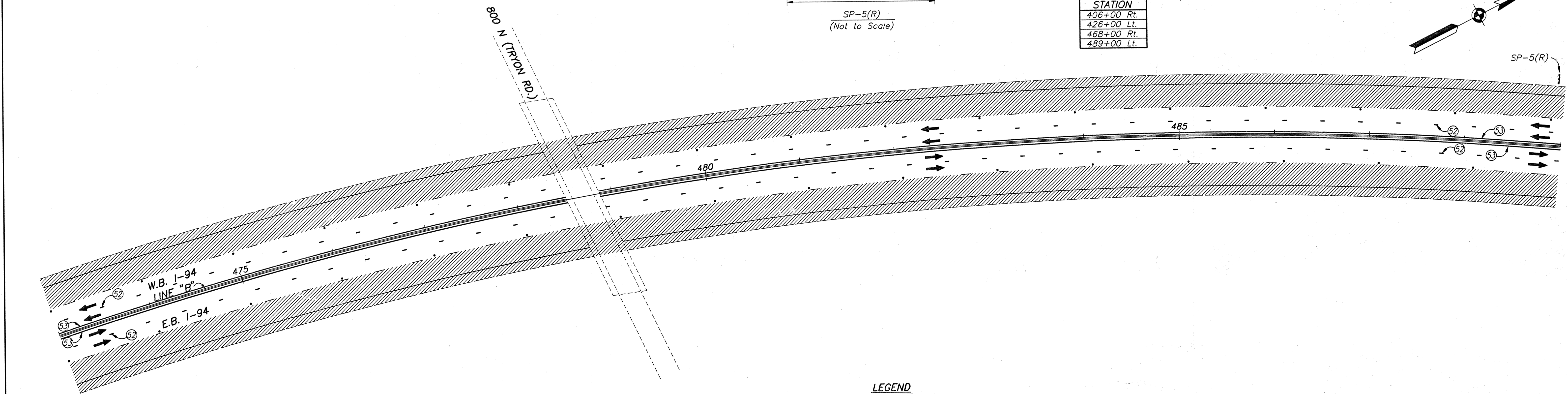
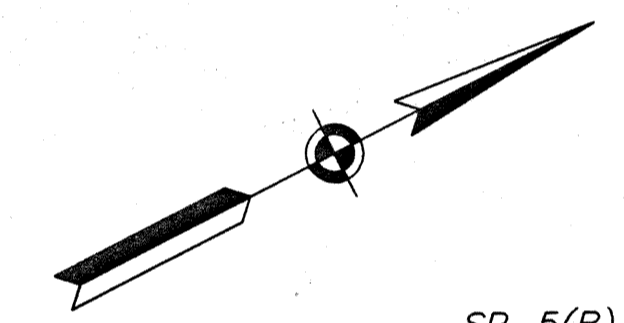

LEGEND

- Section to be Built During Phase III of Construction (See Detail Sheet No.45)
- Paving Exception (See Bridge Plans)
- Type II Barricade or Standard Drum
- Typical Sign Standard with Construction Warning Light Type A
- Temporary Concrete Barrier
- Temporary Pavement Marking Type II, White, 5 in. (4' Spaced 40' C. to C.)
- Temporary Pavement Marking Type II, Yellow, 4 in.

PHASE III MAINTENANCE OF TRAFFIC DETAILS

Scale: 1"=50'

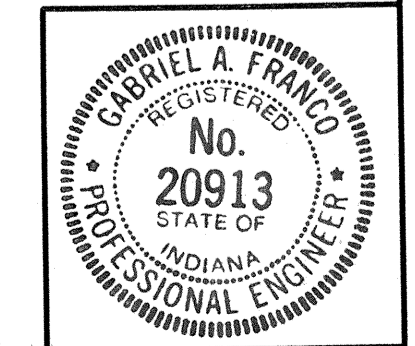

R-20060

G:\CADD\DWG\70171M09.DWG

Rev. 9/14/92
Revised and Replace stl 48

FEDERAL ROAD REGION NO.	STATE	PROJECT NO.	FISCAL YEAR	SHEET NO.	TOTAL SHEETS
5	IND.	STI-94-2()39	1992	48	126

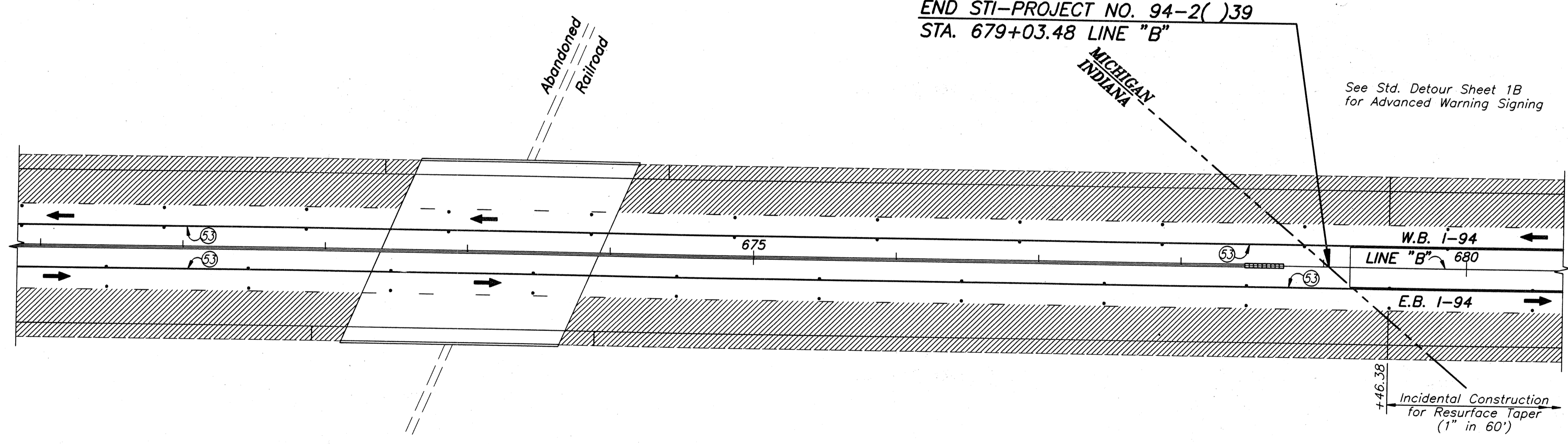
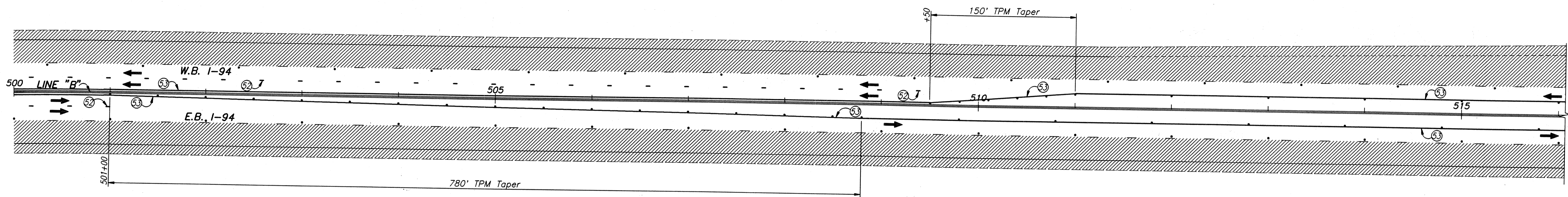
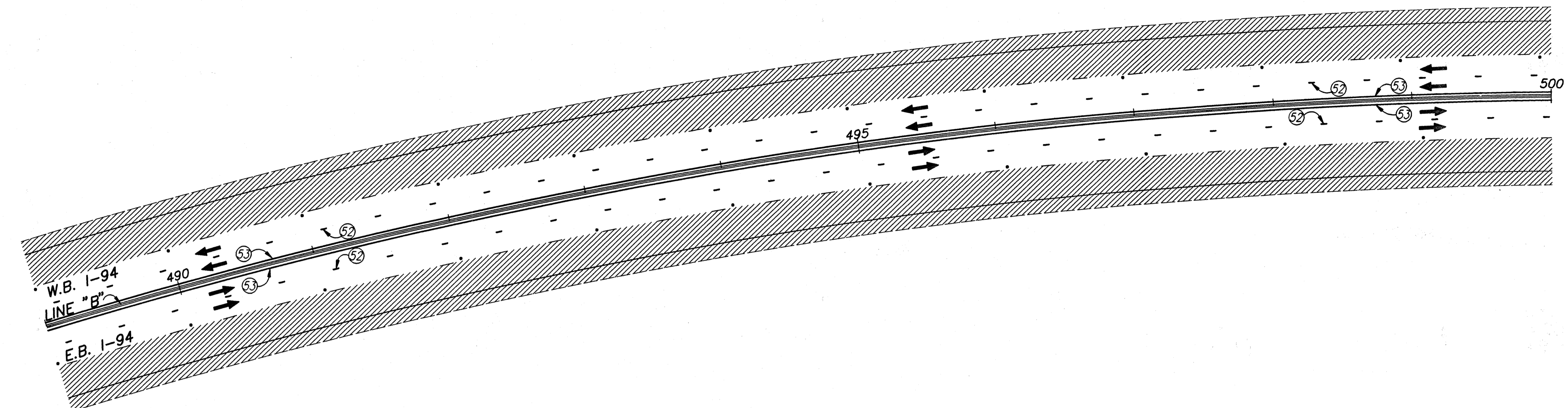
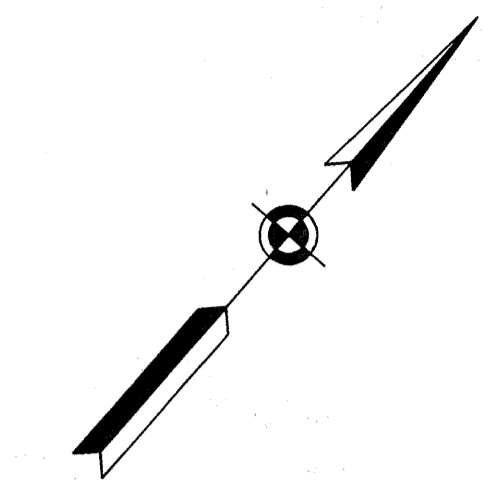

END STI-PROJECT NO. 94-2()39
STA. 679+03.48 LINE "B"

See Std. Detour Sheet 1B
for Advanced Warning Signing

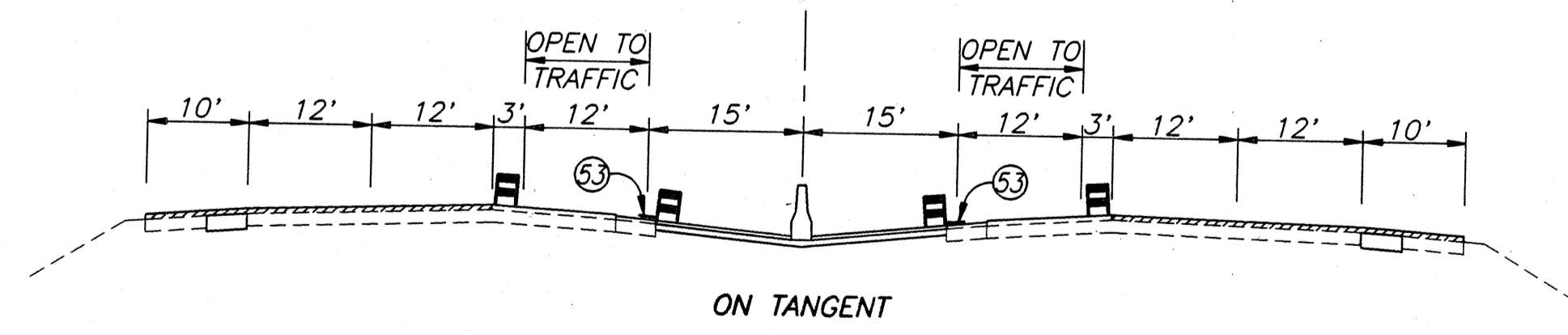

- Sta. 511+00 to 679+46.38 "B"
- Resurface Center Lane and Outside Lane:
165#/Syd. Bituminous Binder 8 or 9, HV on
305#/Syd. Bituminous Base 5, HV
 - Resurface Outside Shoulder:
165#/Syd. Bituminous Binder 8 or 9, LV on
250#/Syd. Bituminous Base 5, LV

- LEGEND**
- Section to be Built During Phase III of Construction
 - Type II Barricade or Standard Drum
 - Temporary Pavement Marking Type II, White, 5 in. (4' Spaced 40' C. to C.)
 - Temporary Pavement Marking Type II, Yellow, 4 in.
 - Temporary Pavement Marking

PHASE. III MAINTENANCE OF TRAFFIC DETAILS

Scale: 1"=50'

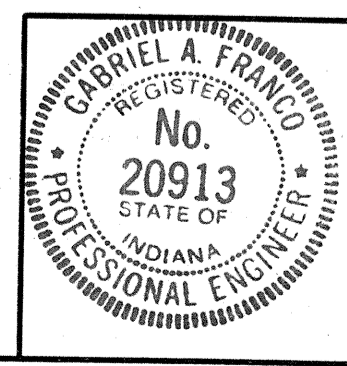

R-20060

G:\CADD\DWG\70171M10.DWG

FEDERAL ROAD REGION NO.	STATE	PROJECT NO.	FISCAL YEAR	SHEET NO.	TOTAL SHEETS
5	IND.	STI-94-2()39	1992	49	126

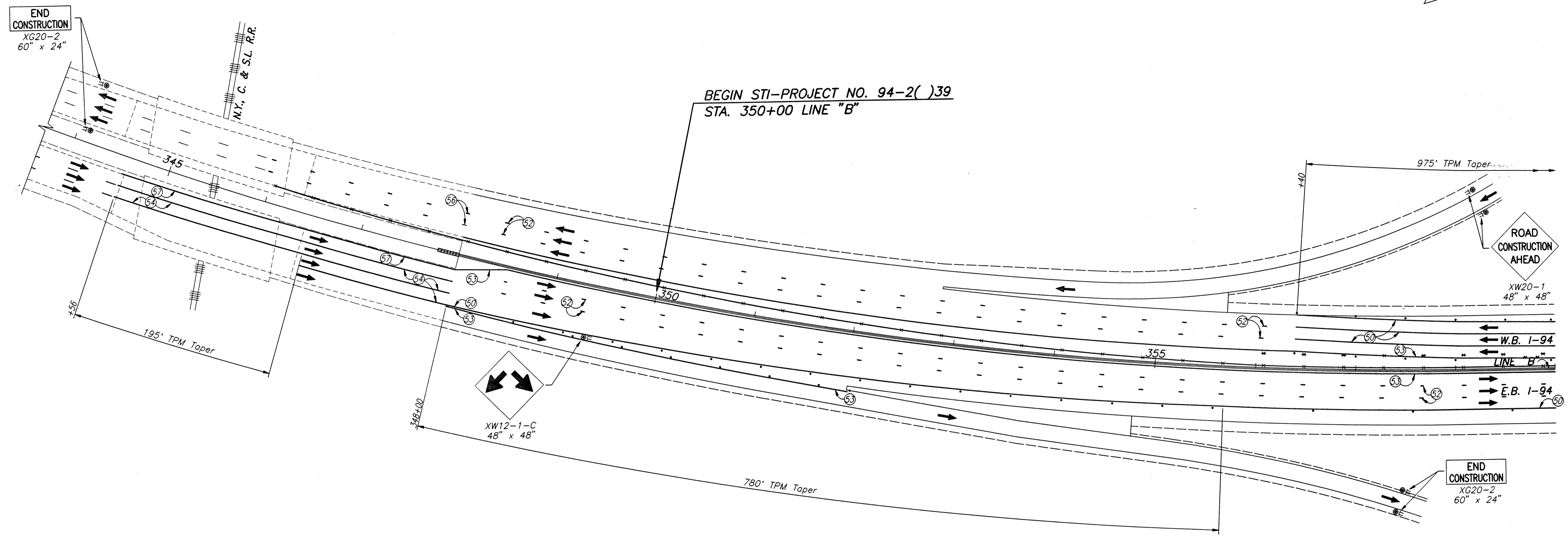
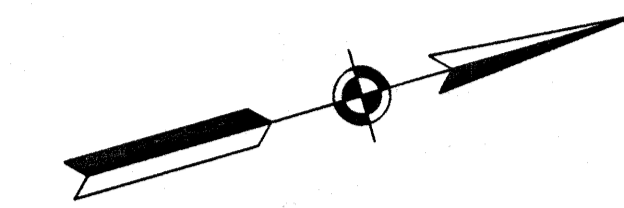

BEGIN STI-PROJECT NO. 94-2()39
STA. 350+00 LINE "B"

LEGEND

- Type II Barricade or Standard Drum
- ⊕ Typical Sign Standard with Construction Warning Light Type A
- Pavement Marking Removal
- ⑤① Temporary Pavement Marking Type II, White, 4 in.
- ⑤② Temporary Pavement Marking Type II, White, 5 in. (4' Spaced 40' C. to C.)
- ⑤③ Temporary Pavement Marking Type II, Yellow, 4 in.
- ⑤④ Temporary Pavement Marking Type I, White, 4 in.
- ⑤⑥ Temporary Pavement Marking Type I, White, 5 in. (4' Spaced 40' C. to C.)
- ⑤⑦ Temporary Pavement Marking Type I, Yellow, 5 in.
- TPM Temporary Pavement Marking

PHASE III-A MAINTENANCE OF TRAFFIC DETAILS

Scale: 1"=50'

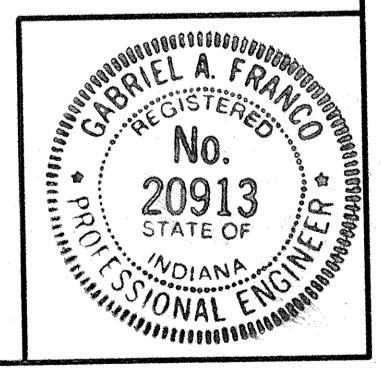

R-20060

G:\CADD\DWG\7017TM11.DWG

FEDERAL ROAD REGION NO.	STATE	PROJECT NO.	FISCAL YEAR	SHEET NO.	TOTAL SHEETS
5	IND.	571-94-2()39	1992	50	126

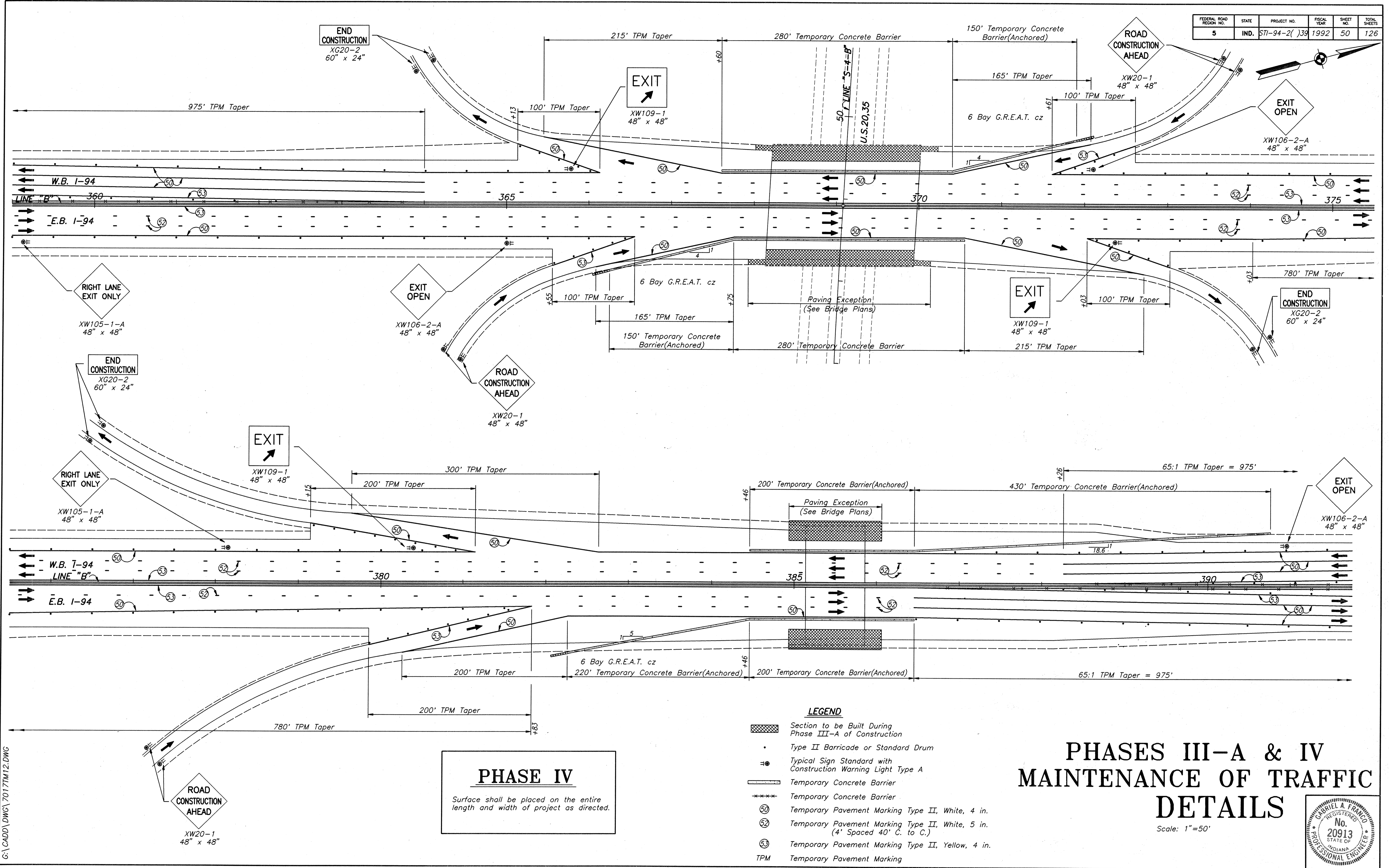

PHASE IV
Surface shall be placed on the entire length and width of project as directed.

- LEGEND**
- Section to be Built During Phase III-A of Construction
 - Type II Barricade or Standard Drum
 - Typical Sign Standard with Construction Warning Light Type A
 - Temporary Concrete Barrier
 - Temporary Concrete Barrier
 - Temporary Pavement Marking Type II, White, 4 in.
 - Temporary Pavement Marking Type II, White, 5 in. (4' Spaced 40' C. to C.)
 - Temporary Pavement Marking Type II, Yellow, 4 in.
 - Temporary Pavement Marking

PHASES III-A & IV MAINTENANCE OF TRAFFIC DETAILS

Scale: 1"=50'

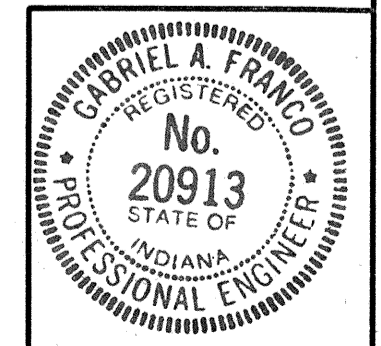

G:\CADD\DWG\70171M12.DWG

LOOP RAMPS

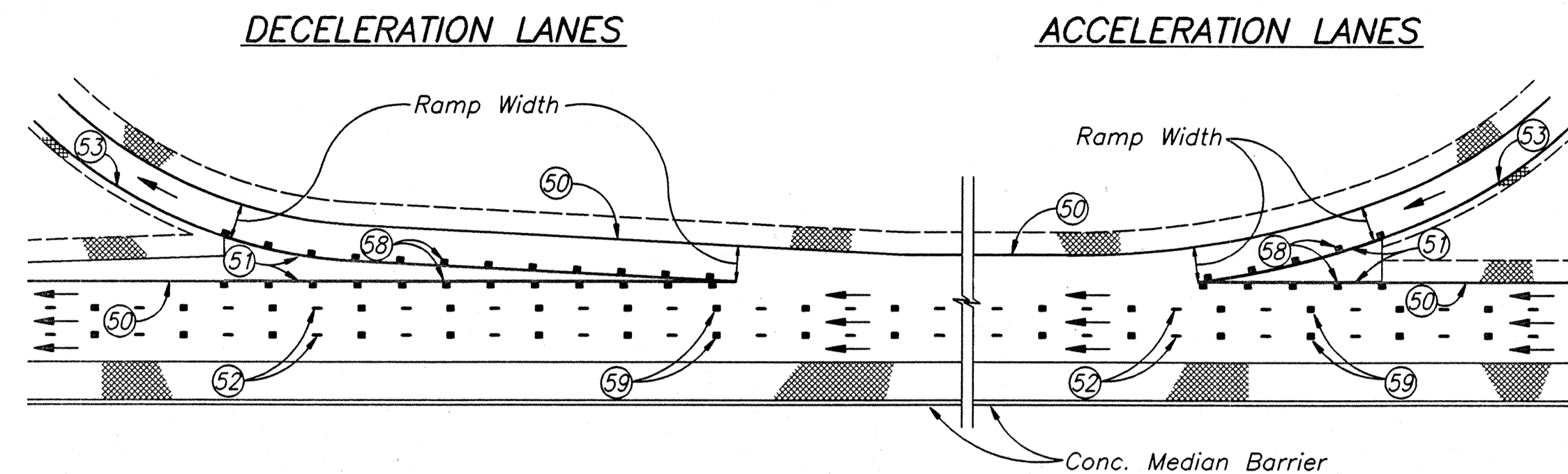

TEMPORARY PAVEMENT MARKINGS ON BINDER COURSE

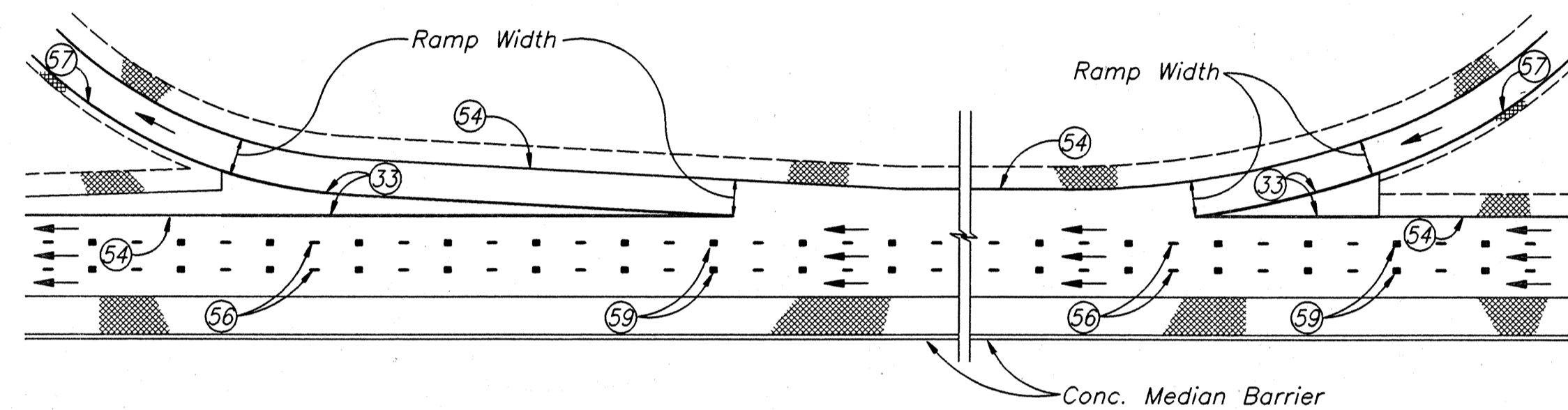

TEMPORARY PAVEMENT MARKINGS ON SURFACE COURSE

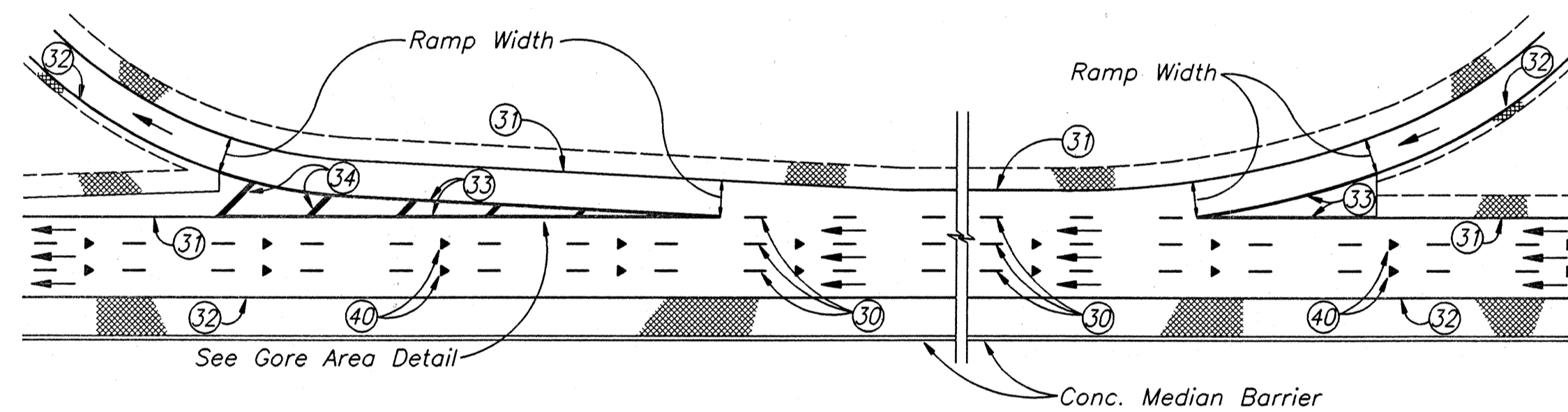

PERMANENT PAVEMENT MARKINGS

CONNECTOR RAMPS

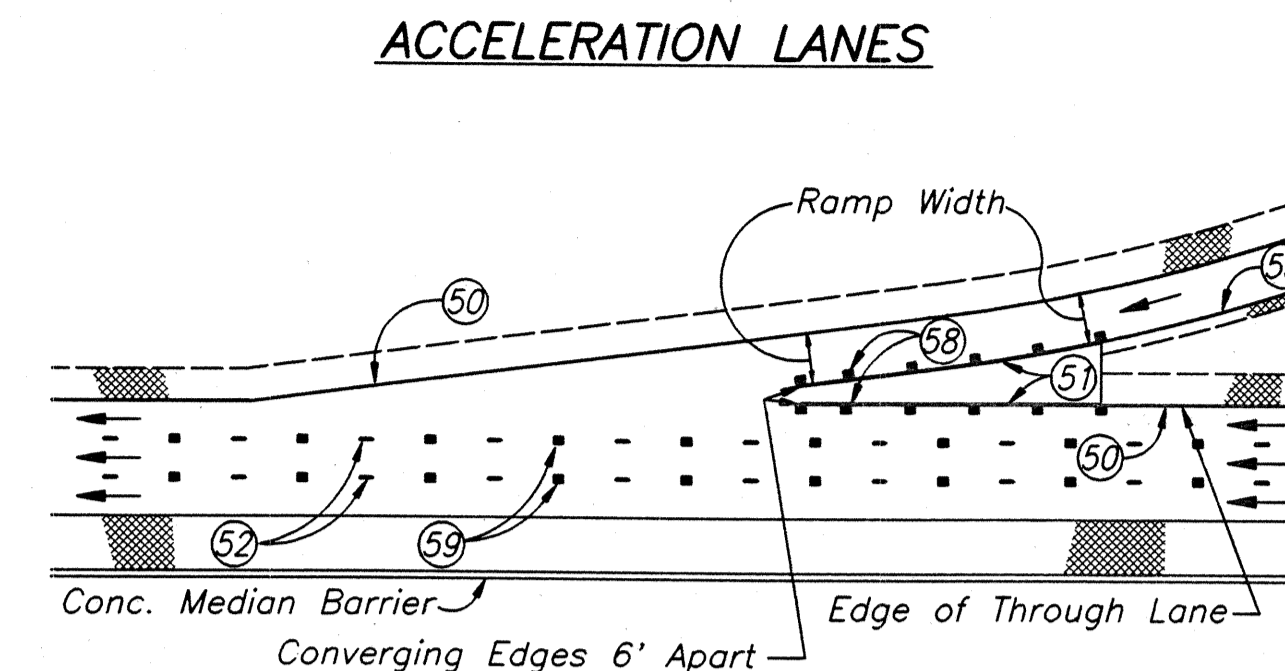

TEMPORARY PAVEMENT MARKINGS ON BINDER COURSE

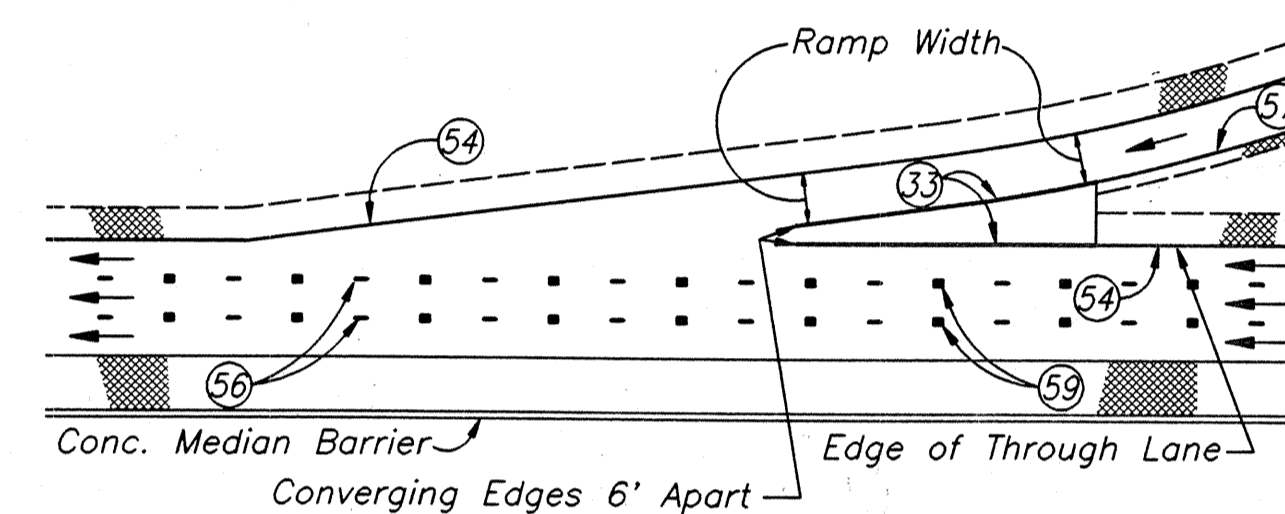
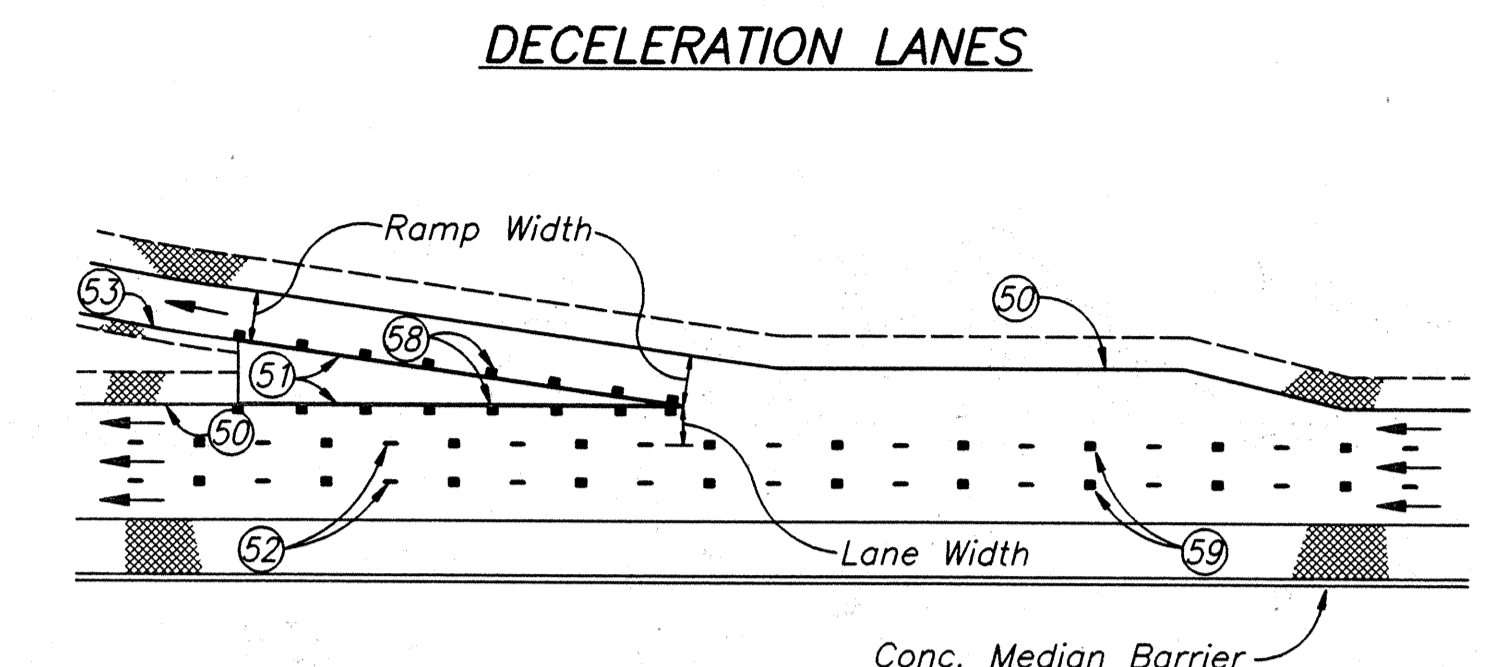

TEMPORARY PAVEMENT MARKINGS ON SURFACE COURSE

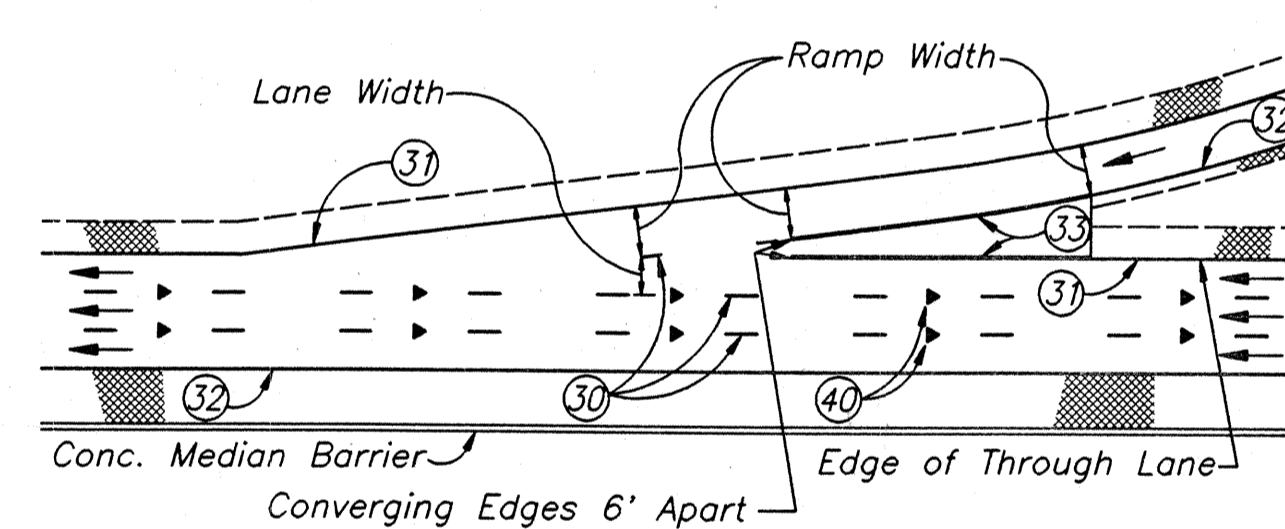
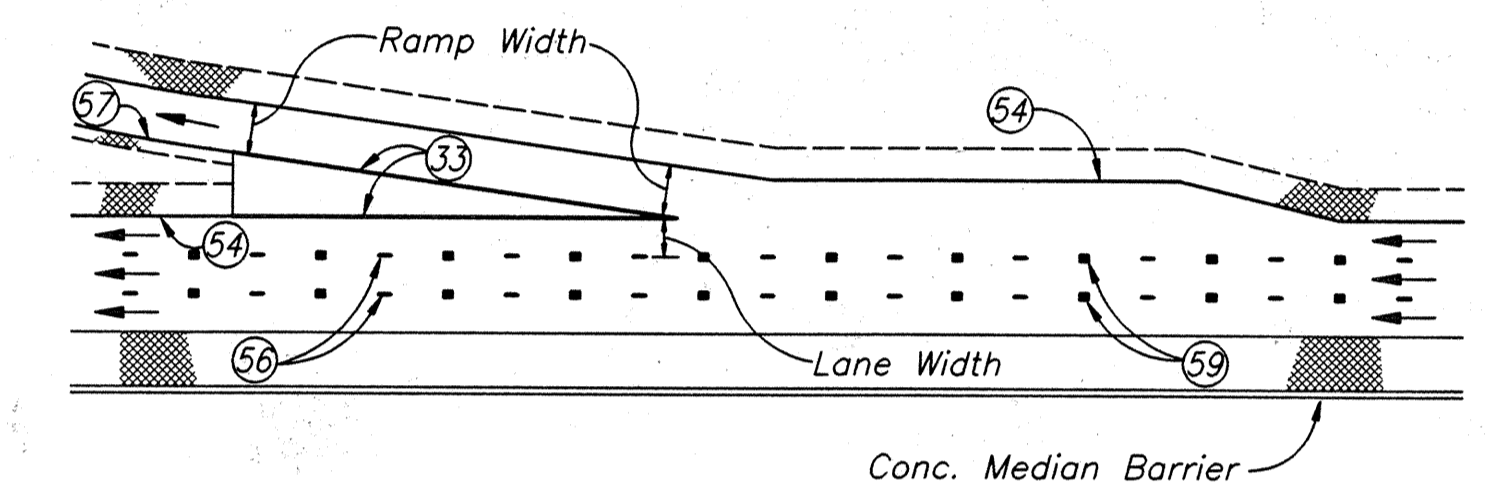

PERMANENT PAVEMENT MARKINGS

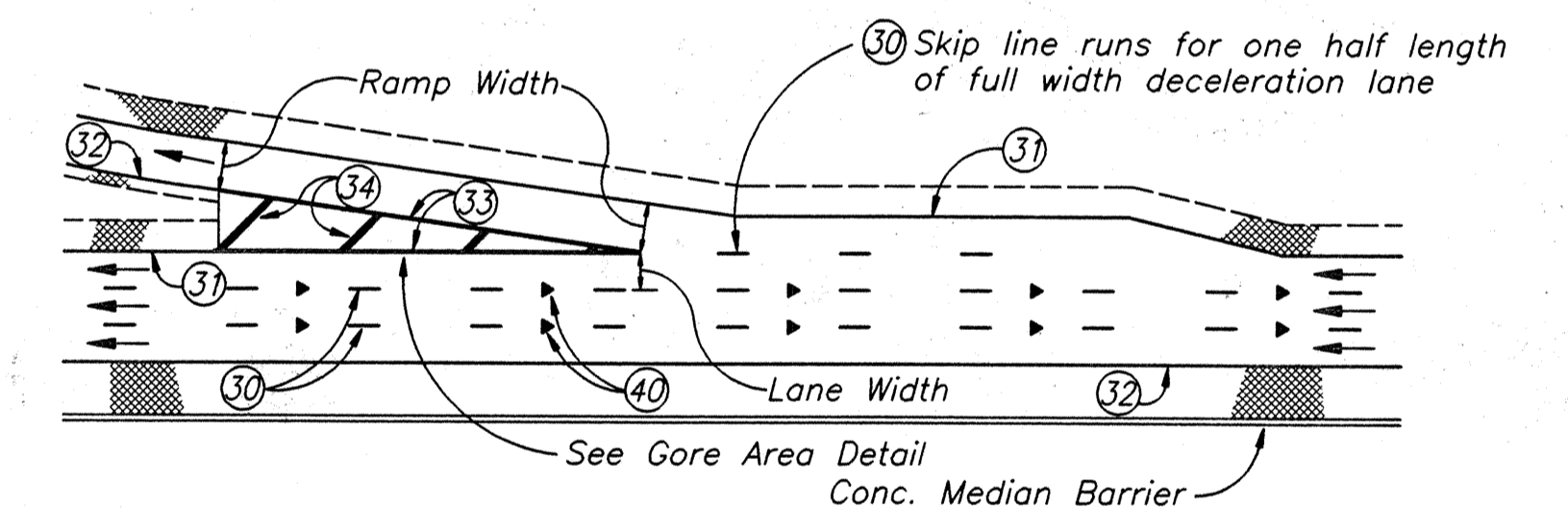

LEGEND

- | | |
|---|---|
| 50 Temporary Pavement Marking Type II, White, 4 in. | 30 Line, Thermoplastic, Broken, White, 5 in. |
| 51 Temporary Pavement Marking Type II, White, 5 in. | 31 Line, Paint, Solid, White, 4 in. |
| 52 Temporary Pavement Marking Type II, White, 5 in. (4' Spaced 40' C. to C.) | 32 Line, Paint, Solid, Yellow, 4 in. |
| 53 Temporary Pavement Marking Type II, Yellow, 4 in. | 33 Line, Thermoplastic, Solid, White, 8 in. |
| 54 Temporary Pavement Marking Type I, White, 4 in. | 34 Line, Thermoplastic, Solid, White, 24 in. |
| 56 Temporary Pavement Marking Type I, White, 5 in. (4' Spaced 40' C. to C.) | 40 Snowplowable Raised Pavement Markers (Spaced 80' C. to C.) (For Gore Areas and Ramps, See Traffic Std. Sheet MT17) |
| 57 Temporary Pavement Marking Type I, Yellow, 4 in. | |
| 58 Temporary Raised Pavement Marker Grade 1 (Spaced 20' C. to C.) | |
| 59 Temporary Raised Pavement Marker Grade 1 (Spaced 40' C. to C. midpoint between temporary markings) | |

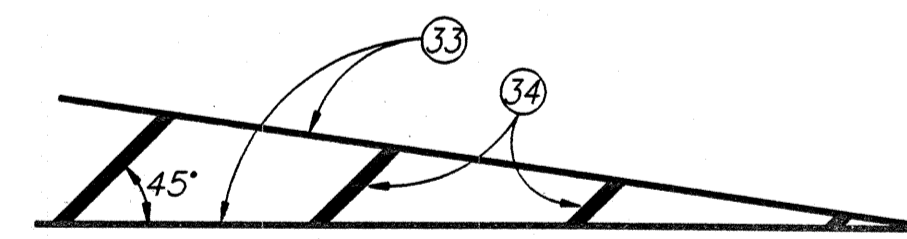

GORE AREA DETAIL

MARKINGS AT BRIDGES

STR. NO.	LIMITS (Approximate Stations)	
	EBL	WBL
2	368+21 to 369+89 "B"	368+26 to 369+94 "B"
3	384+94 to 386+06 "B"	384+94 to 386+06 "B"
5	458+94 to 460+92 "B"	458+94 to 460+92 "B"
9	672+27 to 673+79 "B"	672+52 to 674+04 "B"

- NOTES:
- The Temporary Tape Type II on the Binder Course may remain in place before placing the Surface Course if the Surface Course is to be equal to or greater than 100#/Syd. If the Surface Course is to be less than 100#/Syd., the Temporary Tape shall be removed prior to placing the Surface Course.
 - Temporary Pavement Markings and Temporary Raised Pavement Markers shall be removed prior to placing the final striping. The Bissymmetric Tape shall remain in place as the final markings.
 - For details not shown, use the Indiana Manual on Uniform Traffic Control Devices.

TEMPORARY AND PERMANENT PAVEMENT MARKING DETAILS

Not to Scale

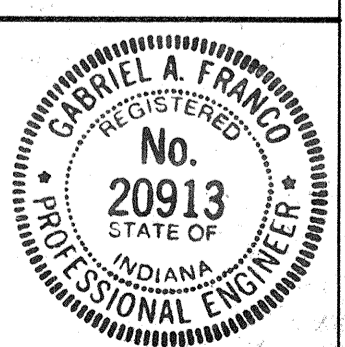

R-20060

17017PMD

FEDERAL ROAD DISTRICT NO.	STATE	PROJECT NO.	FISCAL YEAR	SHEET NO.	TOTAL SHEETS
5	IND.	STI-94-2()39	1992	52	126

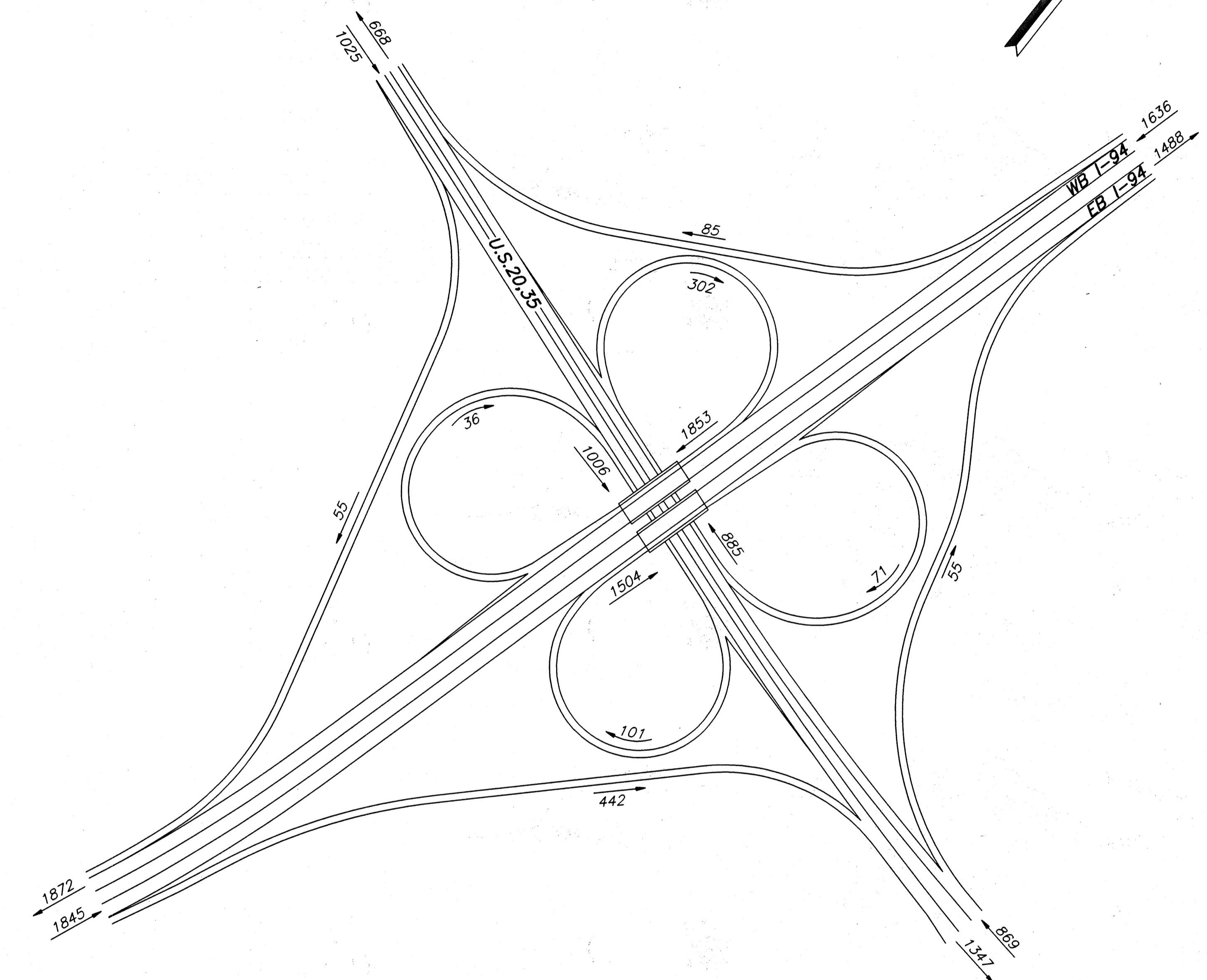
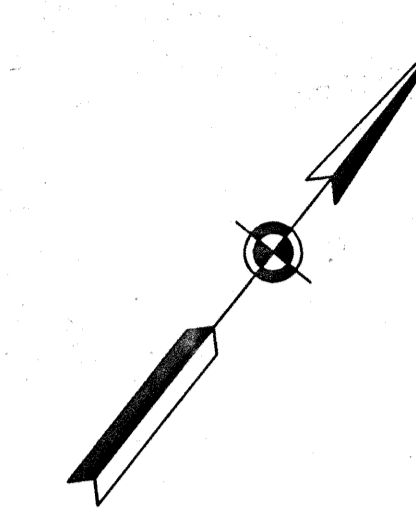

**D.H.V. TRAFFIC FLOW DIAGRAM
YEAR 2002-P.M. PEAK**

DETAILS
No Scale

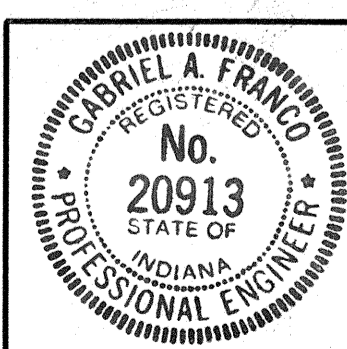

R-20060

G:\CADD\DWG\7017DE03.DWG

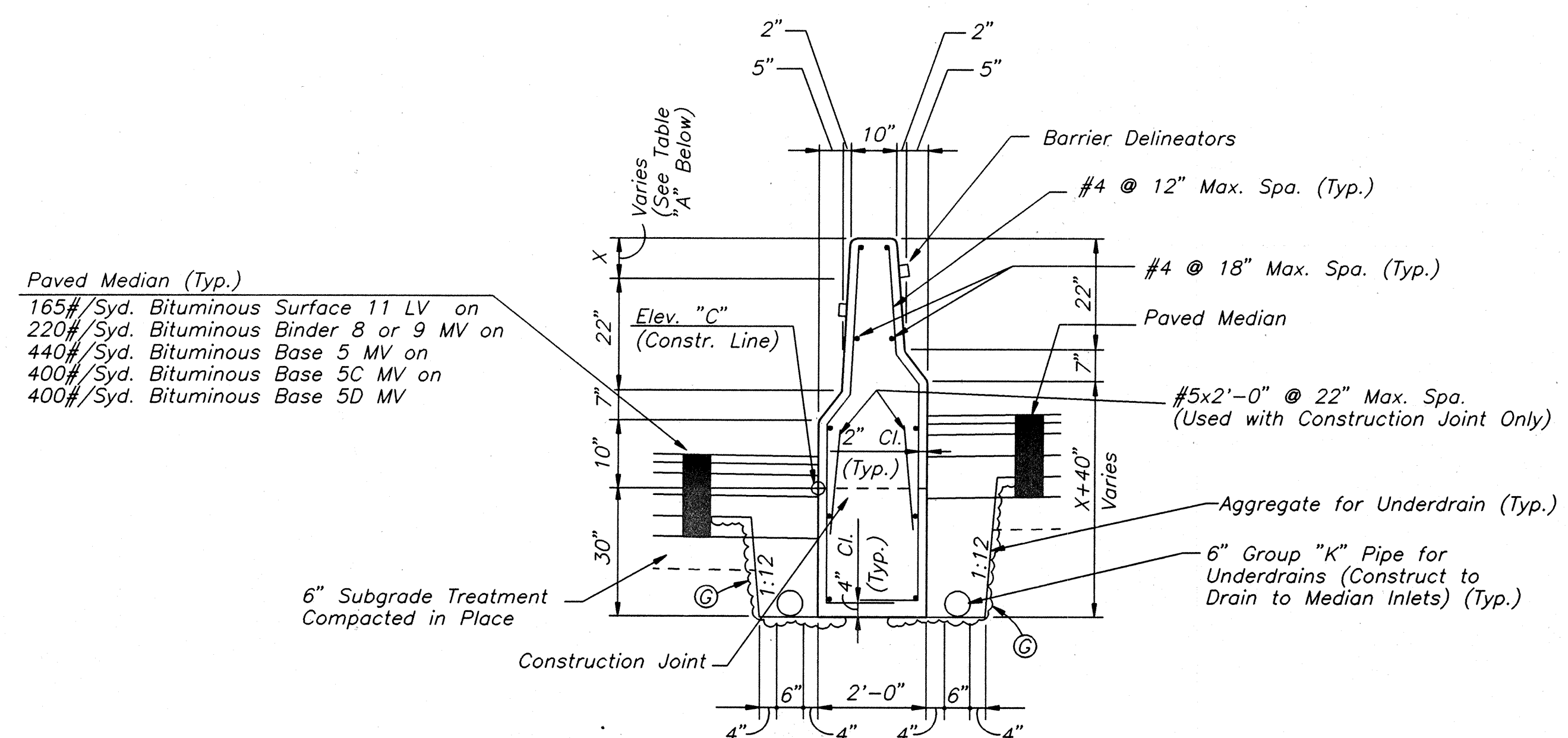

**SPECIAL CONCRETE MEDIAN BARRIER
DETAILS ON CURVE TO THE RIGHT
(REVERSE FOR CURVE TO THE LEFT)**

STA.	ELEV. "C"	DIM. X (FT.)
348+00	670.56	0.30
349+00	668.79	1.14
350+00	667.35	1.23
351+00	665.76	1.30
351+14.83	665.54	1.30
351+63.17	664.76	1.30
352+00	664.16	1.30
353+00	662.55	1.30
354+00	660.88	1.30
355+00	659.29	1.30
356+00	658.03	1.30
357+00	657.81	1.30
358+00	655.95	0.97
359+00	655.28	0.62
360+00	654.73	0.0
408+00	664.91	0.0
409+00	666.11	0.23
410+00	667.30	0.58
411+00	668.44	0.67
412+00	669.46	0.91
413+00	670.45	1.07
414+00	671.56	1.10
415+00	672.64	1.10
415+25	672.93	1.10
415+65	673.38	1.10
416+00	673.67	1.10

STA.	ELEV. "C"	DIM. X (FT.)
417+00	674.80	1.07
418+00	676.20	0.85
419+00	677.11	0.69
420+00	677.62	0.69
421+00	677.92	0.69
422+00	677.80	0.69
423+00	677.47	0.69
424+00	676.86	0.66
425+00	675.99	0.57
426+00	675.01	0.21
427+00	673.63	0.06
428+02	673.16	0.00
466+00	670.00	0.00
467+49	666.30	0.66
468+00	665.11	0.53
469+00	662.34	1.05
470+00	659.74	1.31
471+00	657.41	1.40
472+00	655.44	1.54
473+00	653.71	1.39
474+00	652.32	1.40
475+00	651.21	1.33
476+00	650.36	1.26
477+00	650.11	1.00
477+77	649.92	0.97
478+50	649.74	1.06

STA.	ELEV. "C"	DIM. X (FT.)
478+89	649.64	1.12
479+00	649.61	1.13
480+00	649.37	1.25
481+00	649.12	1.32
482+00	648.87	1.45
483+00	648.62	1.63
484+00	648.80	1.33
485+00	648.98	1.06
486+00	648.54	1.39
487+00	648.10	1.76
488+00	648.30	1.43
489+00	648.50	1.08
490+00	648.08	1.40
491+00	647.65	1.70
492+00	647.83	1.46
493+00	648.01	1.13
494+00	647.59	1.47
495+00	647.17	1.72
496+00	647.35	1.43
497+00	647.53	1.13
498+00	647.26	1.27
499+00	646.99	1.44
500+00	647.19	1.11
501+00	647.39	0.65
502+00	647.11	0.62
503+00	646.83	0.28
504+00	647.03	0.0

TABLE "A"

Notes:
 For Details not shown, See Standard Sheet CB-1
 See Table "A" for Elev. "C" and Dimension "X".
 Lap Horizontal Steel 1'-4" Min. at Construction Joints.
 Chamfer All exposed edges 1".
 Surface Seal all above ground Concrete Surface.
 All Reinforcing Steel to be Epoxy Coated.
 All Excavation, Disposal, Backfill, Surface Sealing, Joints, Masonry Coating, Finishing, and other Miscellaneous Items necessary to complete the Structure will not be paid for directly but will be included in the cost of Pay Items.
 The 6" Group "K" Pipe for Underdrains, Aggregate for Underdrains and the Barrier Delineators will be Measured and Paid for separately.
 Material Properties are Concrete $f_c=3000$ PSI and Reinforcing Steel $f_s=20,000$ PSI (Grade 40)

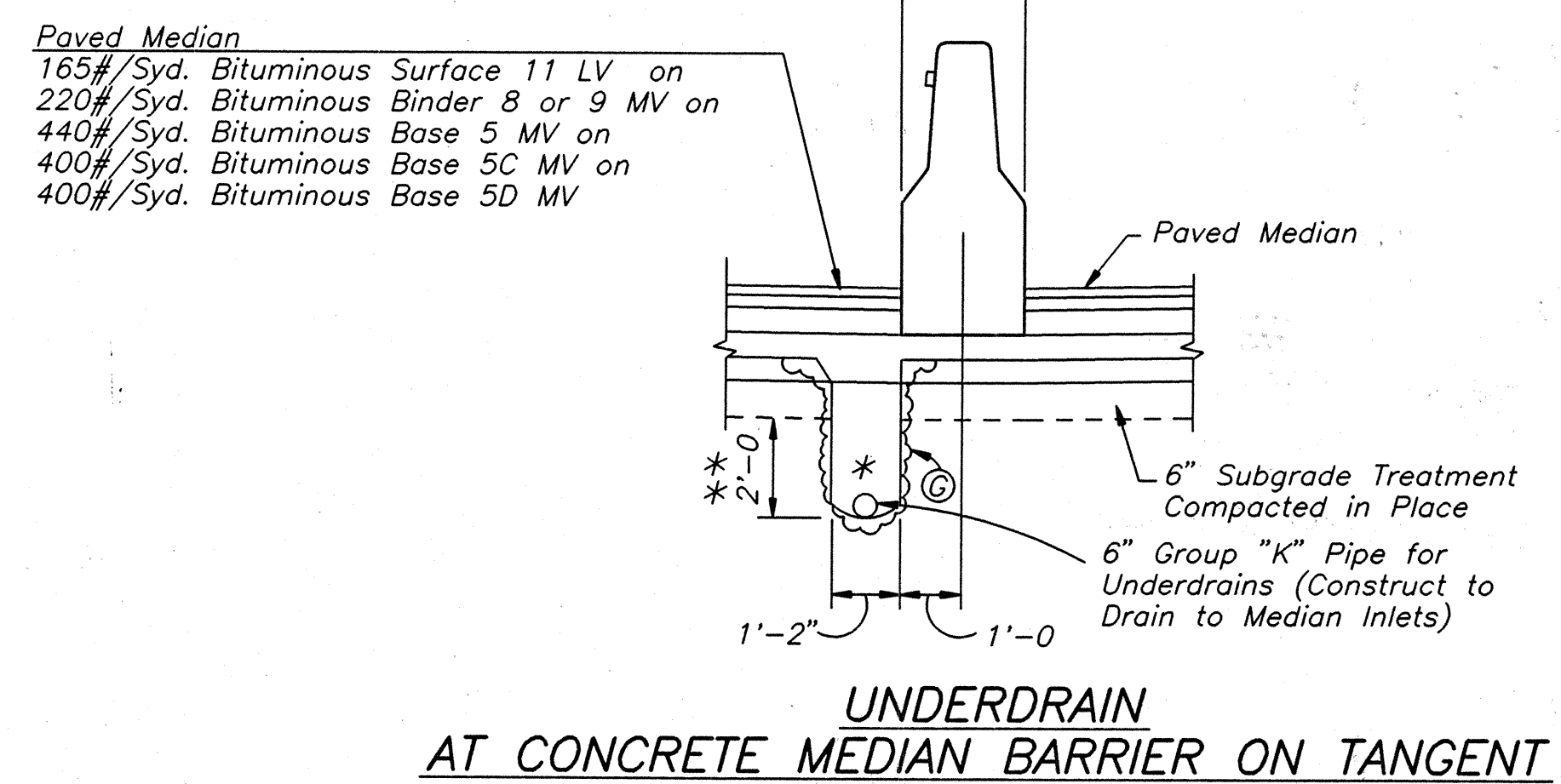

**UNDERDRAIN
AT CONCRETE MEDIAN BARRIER ON TANGENT**

STA. 360+00 TO STA. 408+00 "B"
 STA. 427+50 TO STA. 466+30 "B"
 STA. 504+00 TO STA. 511+00 "B"

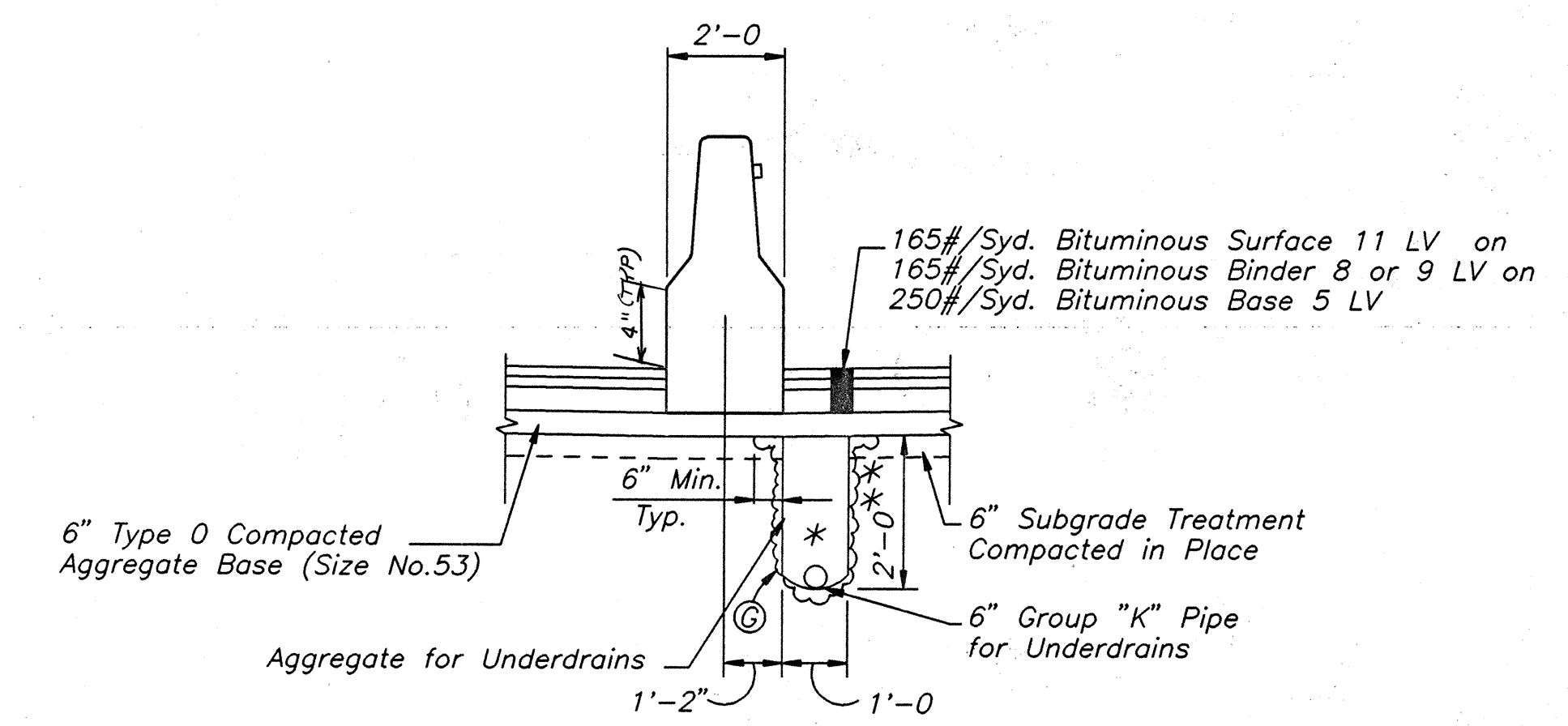

**UNDERDRAIN
AT CONCRETE MEDIAN BARRIER ON TANGENT**

STA. 511+00 TO STA. 679+03.48 "B"

Notes:
 See Miscellaneous Standards Sheet MN for more information and Details.
 * Only One Underdrain is Req'd. at the Concrete Barrier on Tangent Section (For Location Lt. or Rt. See Underdrain Table)
 ** Varies as shown on Underdrain Table

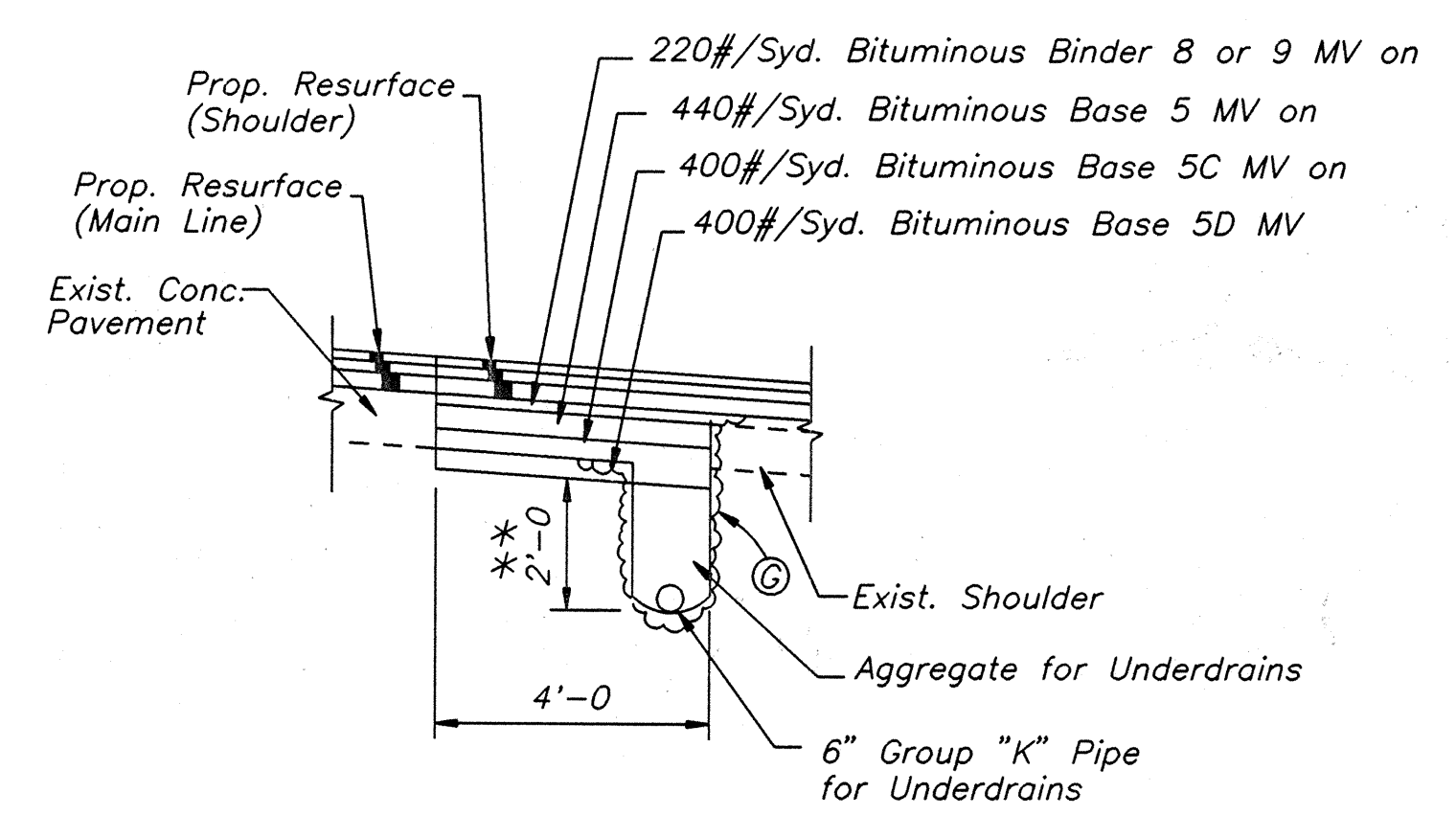

**UNDERDRAIN
AT OUTSIDE SHOULDER**

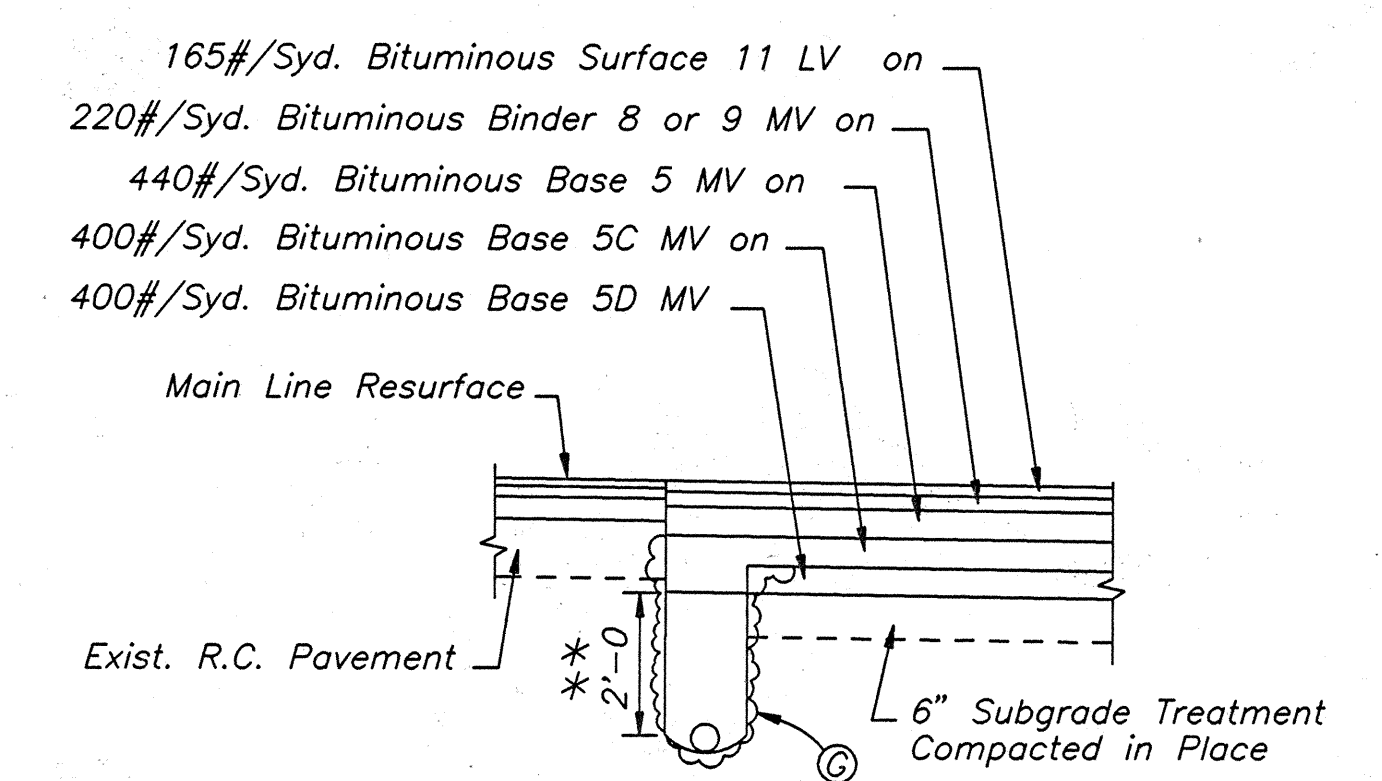

**UNDERDRAIN
AT INSIDE EDGE OF PAVEMENT**

STA. 348+00 TO STA. 510+95 "B"

DETAILS

SCALE: NONE

Geotextile for Underdrains

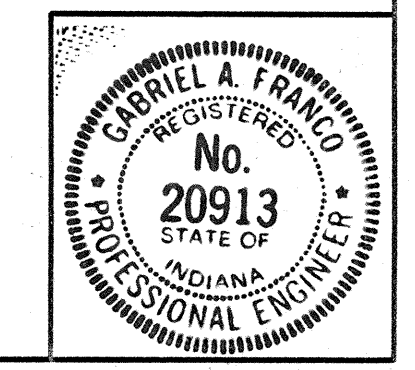

R-20060

7017DE01 BY:MP 8/3/92

FEDERAL ROAD REGION NO.	STATE	PROJECT NO.	FISCAL YEAR	SHEET NO.	TOTAL SHEETS
5	IND.	571-94-2()39	1992	54	126

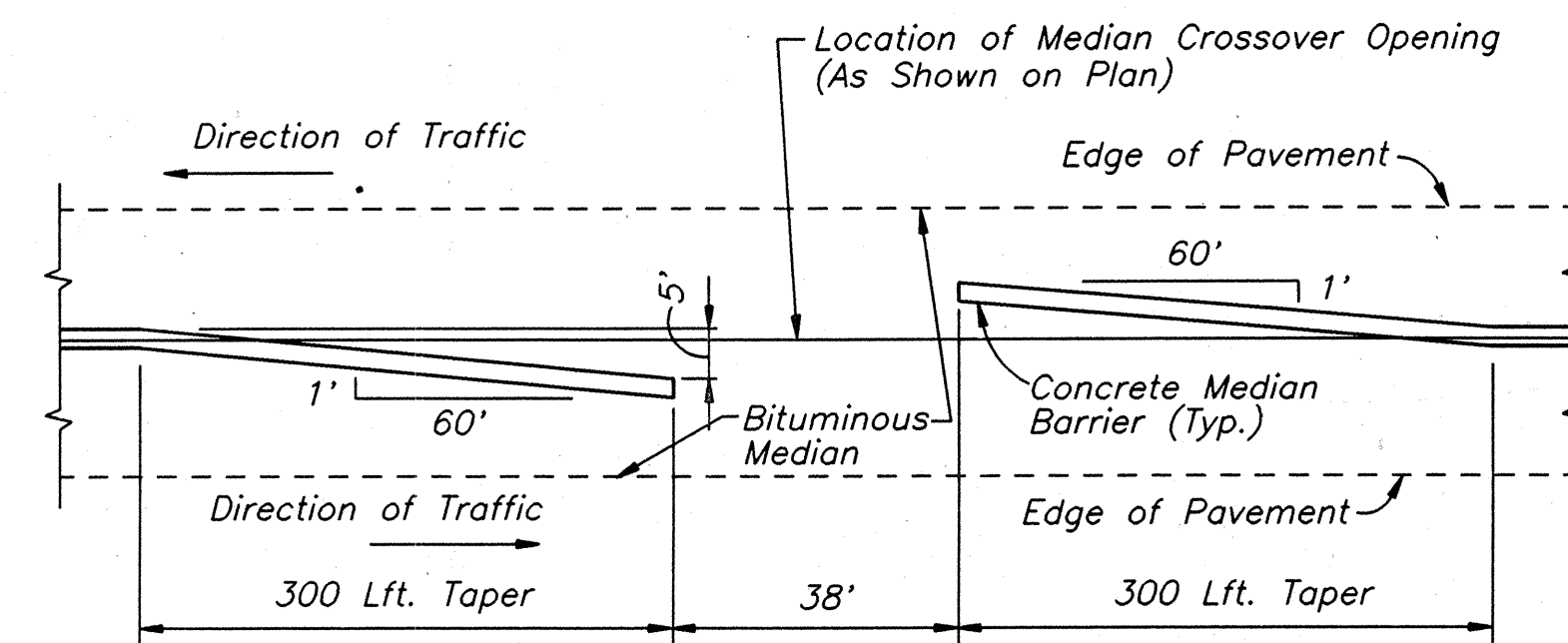

MEDIAN CROSSOVER OPENING

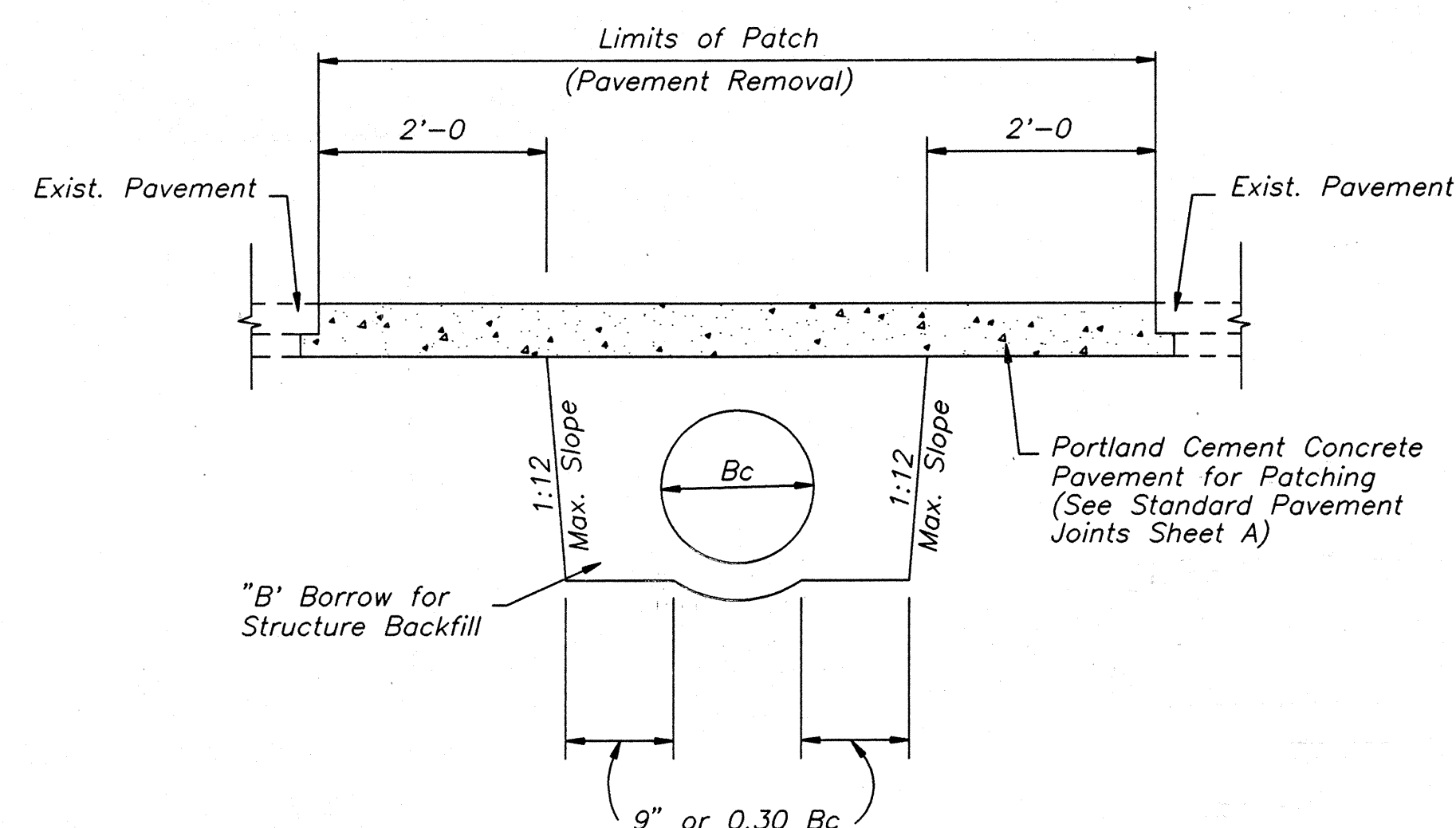

DETAIL FOR PLACING PIPE UNDER EXISTING ROADWAY

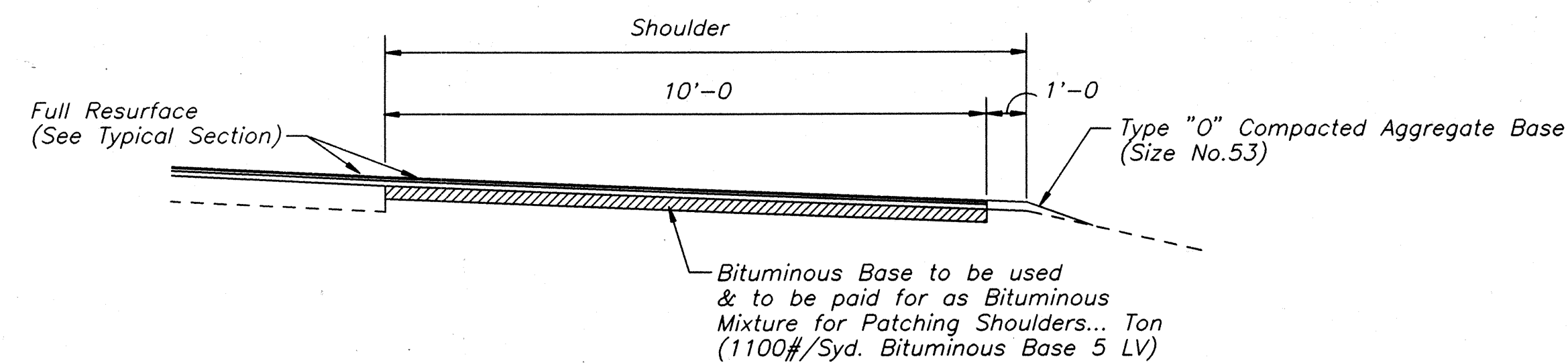

SHOULDER PATCHING DETAIL

DETAIL FOR BEGINNING AND END OF RESURFACING

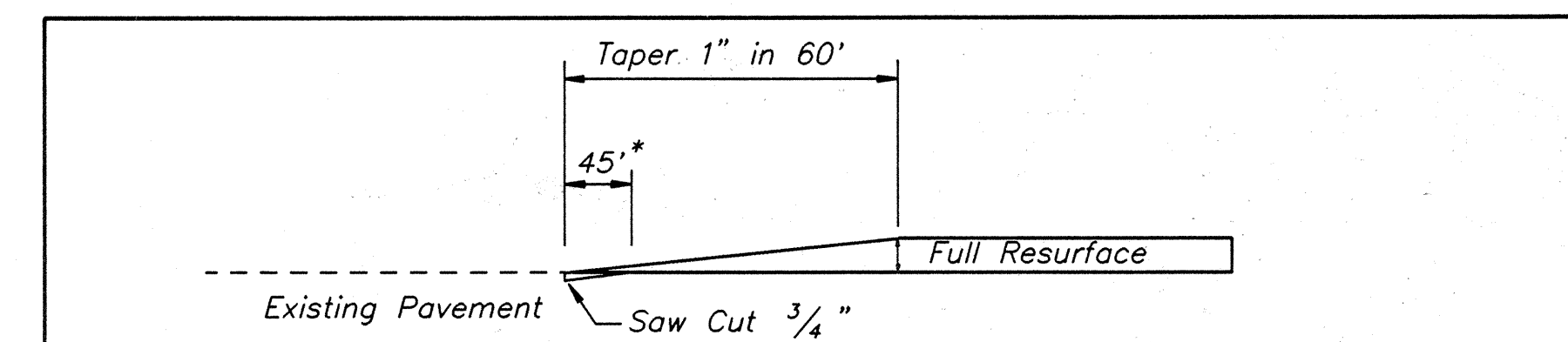

FOR PROJECT BEGINNING OR TERMINATING ON EXISTING PAVEMENT

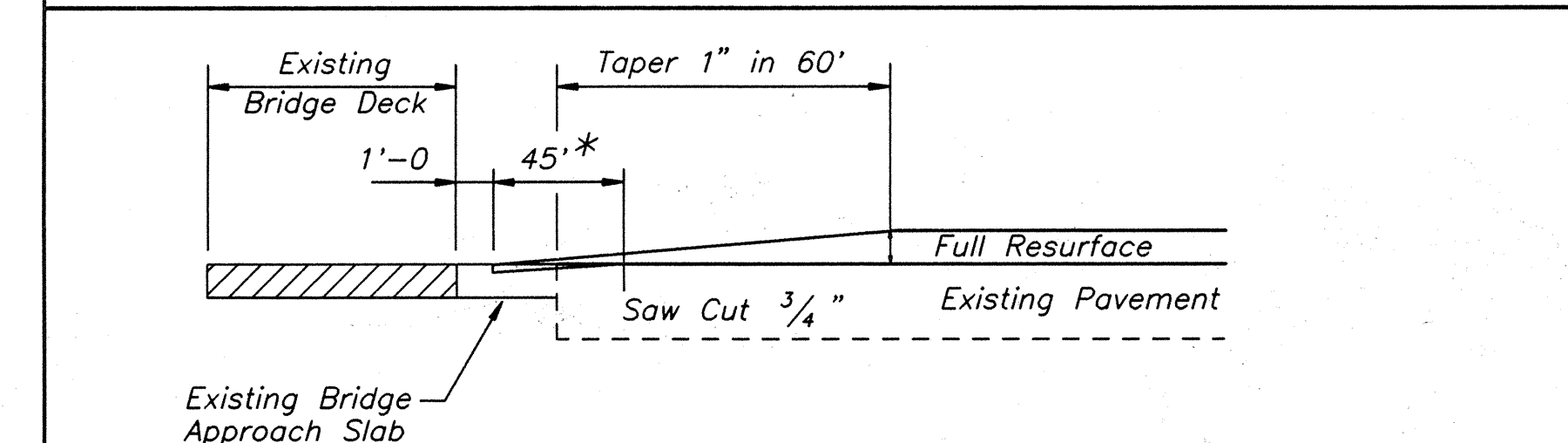

FOR PROJECT EXCEPTION BEGINNING OR TERMINATING AT BRIDGE DECK @ STR. NO.2 & 9

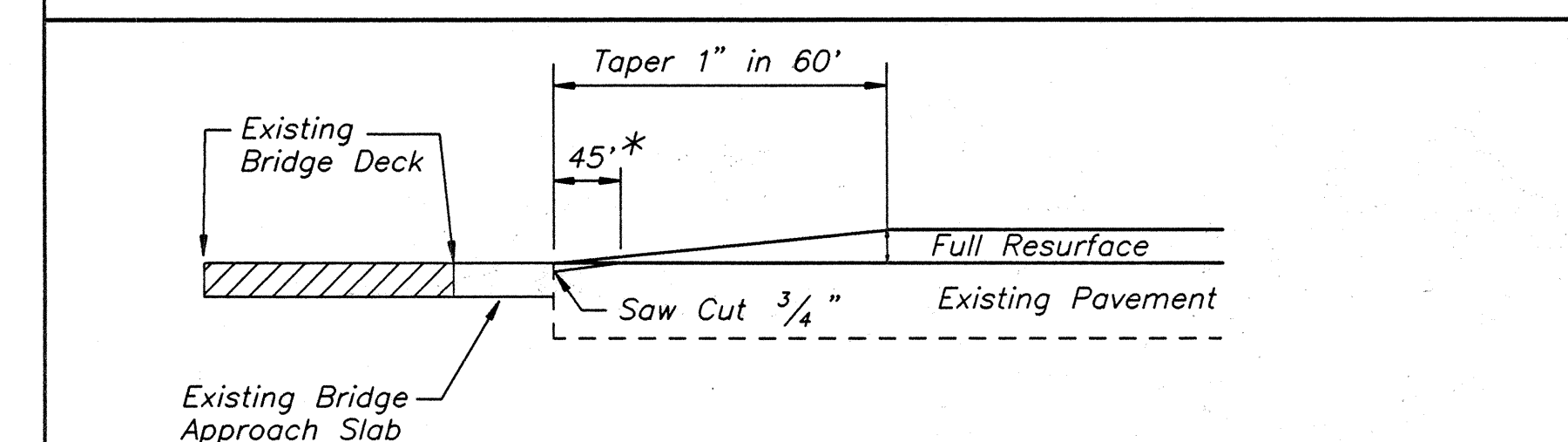

FOR PROJECT EXCEPTION BEGINNING OR TERMINATING AT BRIDGE R.C. SLAB @ STR. NO.3 & 5

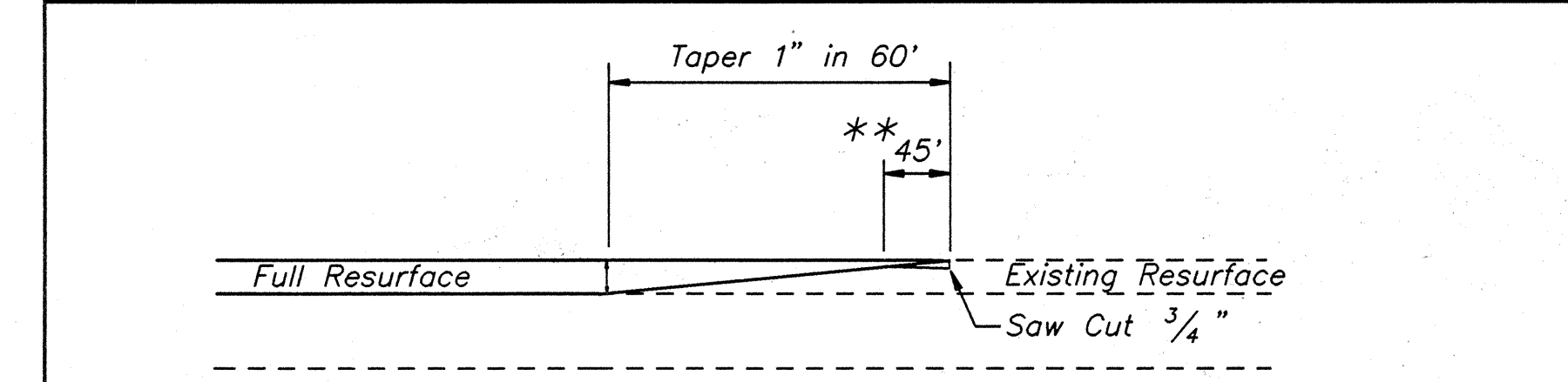

FOR PROJECT BEGINNING OR TERMINATING AT EXISTING RESURFACE

* Scarify 0" to 3/4" as shown, to be paid for as "Surface Milling, Portland Cement Concrete" in Sys.

** Scarify 0" to 3/4" as shown, to be paid for as "surface Milling, Bituminous" in Sys.

DETAILS

SCALE: NONE

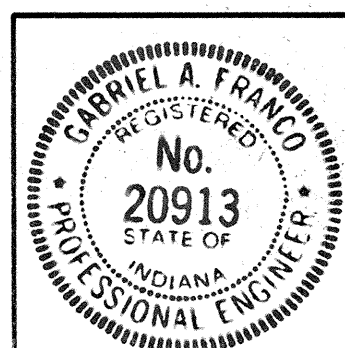

R-20060

7017DE02 BY:MP 8/2/92

FEDERAL ROAD REGION NO.	STATE	PROJECT NO.	FISCAL YEAR	SHEET NO.	TOTAL SHEETS
5	IND.	ST-1-94-2(1)39	1992	55	126

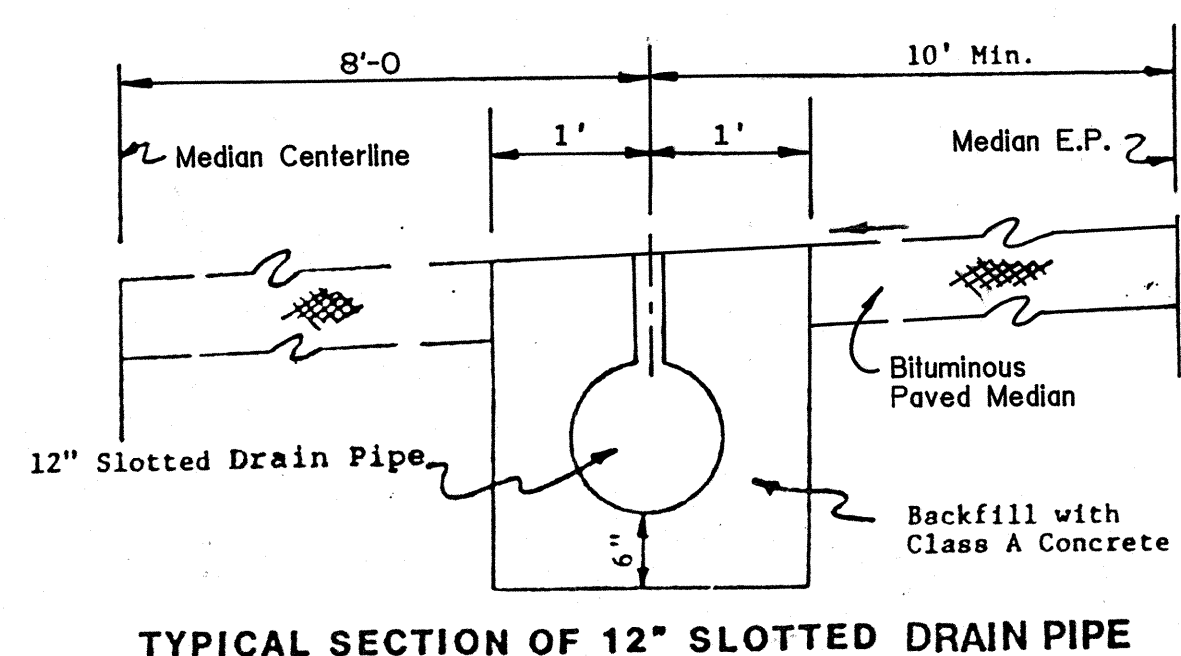
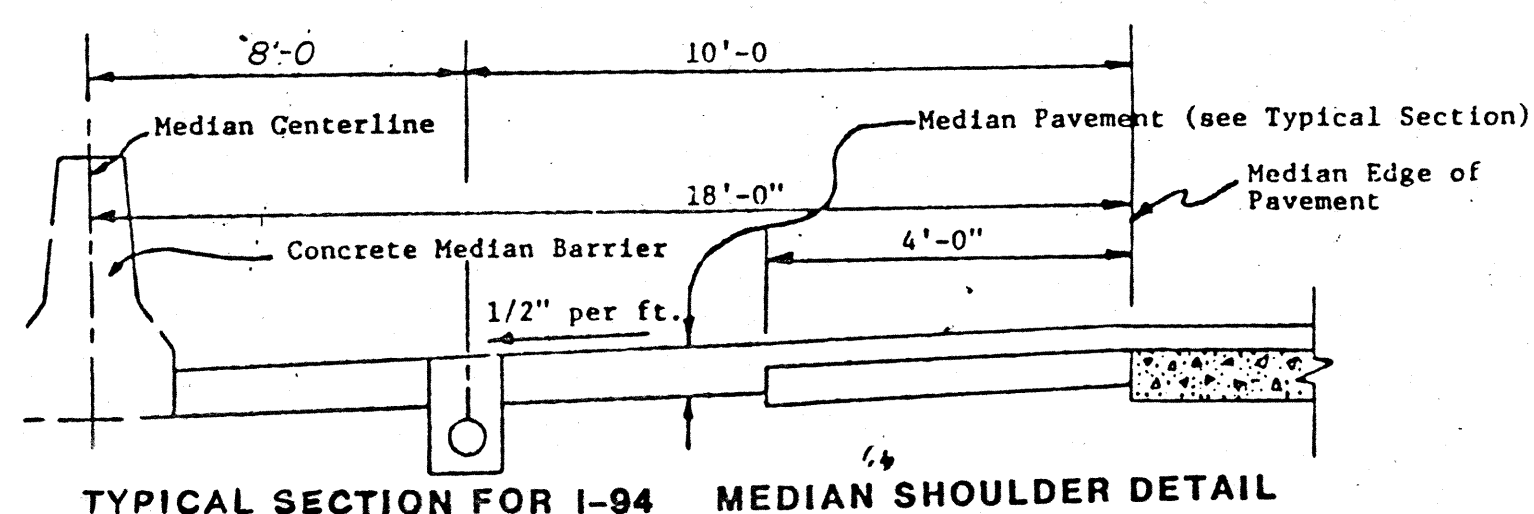
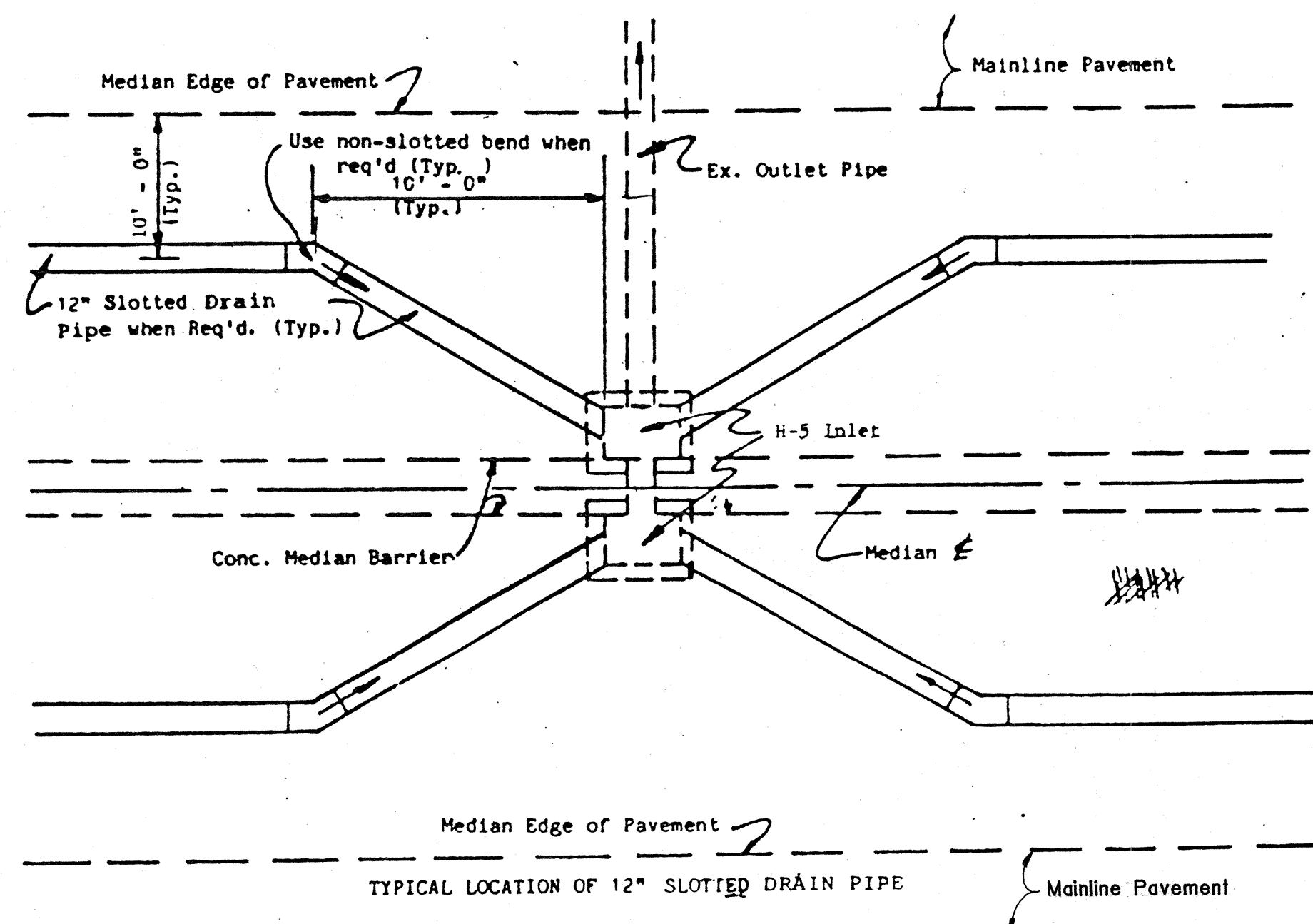

Note: Full pavement on median shall be placed first and then saw cut for the installation of the slotted drain.

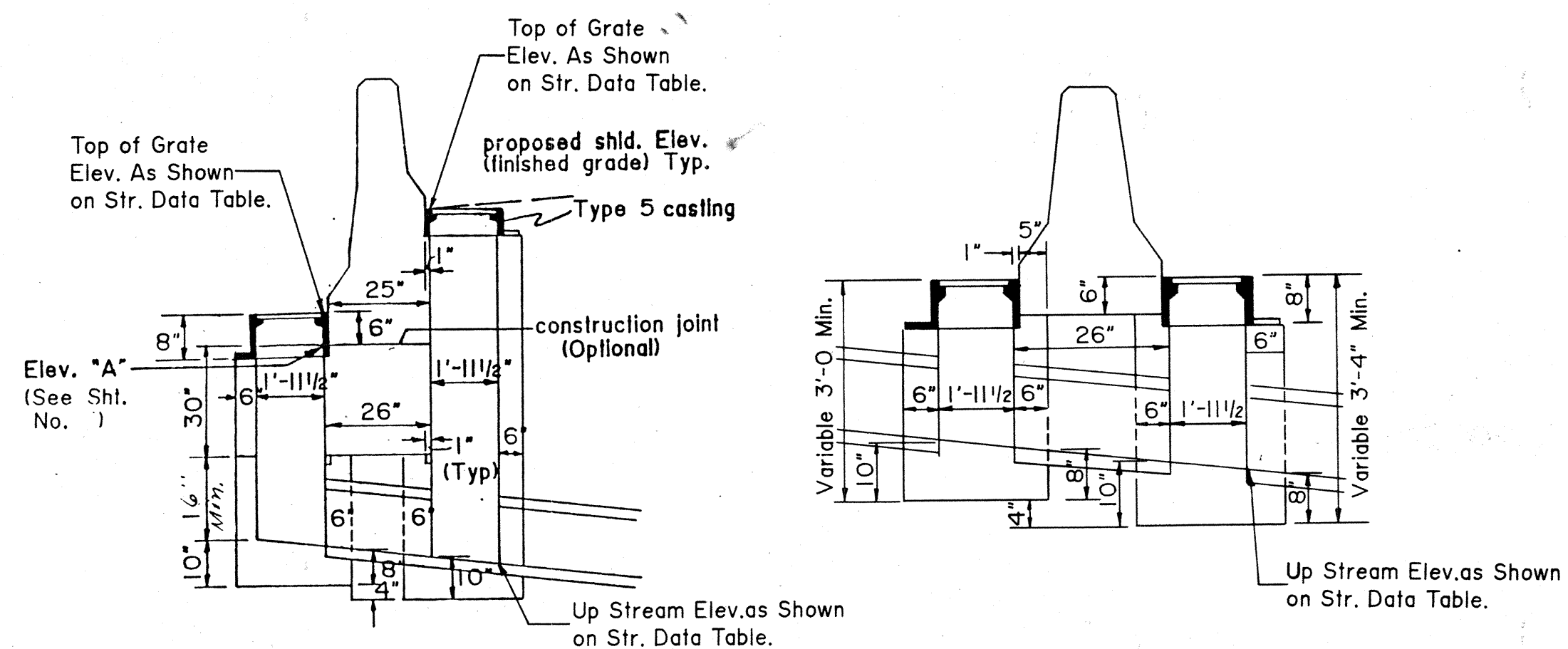

NOTES: 8" Below top of Casting Conc. Barrier wall will be widened 1" ea. side to provide ledge for sealing casting. (See Miscellaneous Standard Sheet CB-1 for more details and information.)
 H-5 MODIFIED INLET FOR SUPERELEVATION SECTION
 H-5 MODIFIED INLET FOR TANGENT SECTION

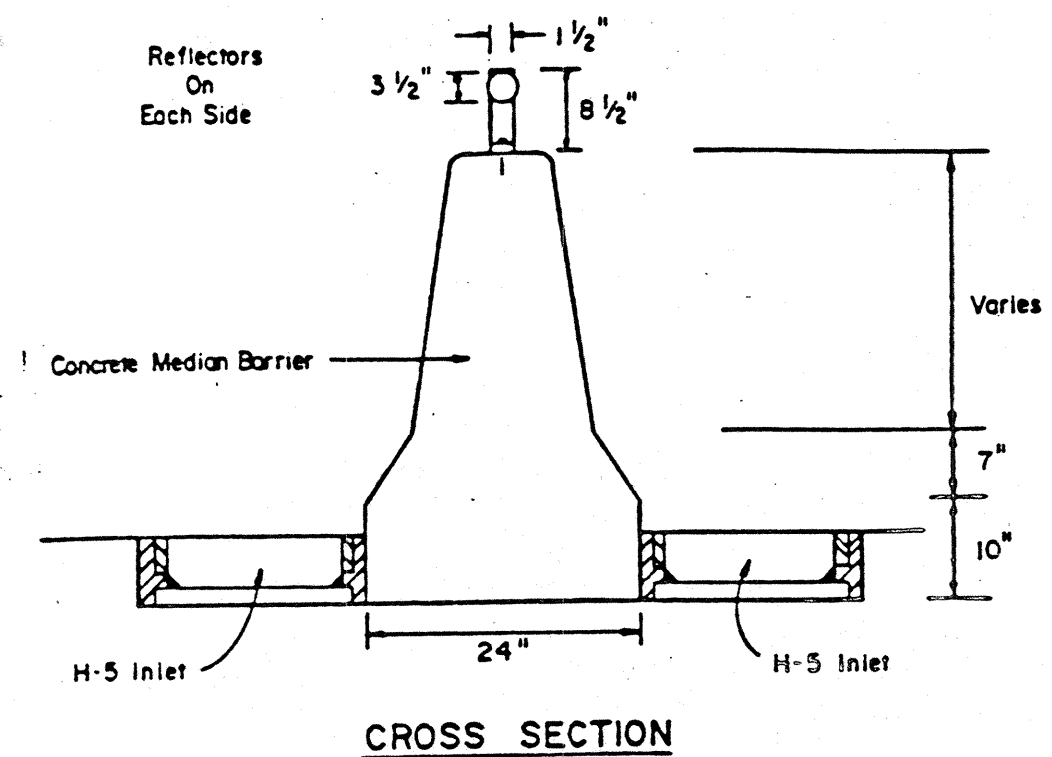

All work & materials required in the installation of the reflectors, shall be included in the pay item: Delineator Assembly, Concrete Median Barrier - - - Each.

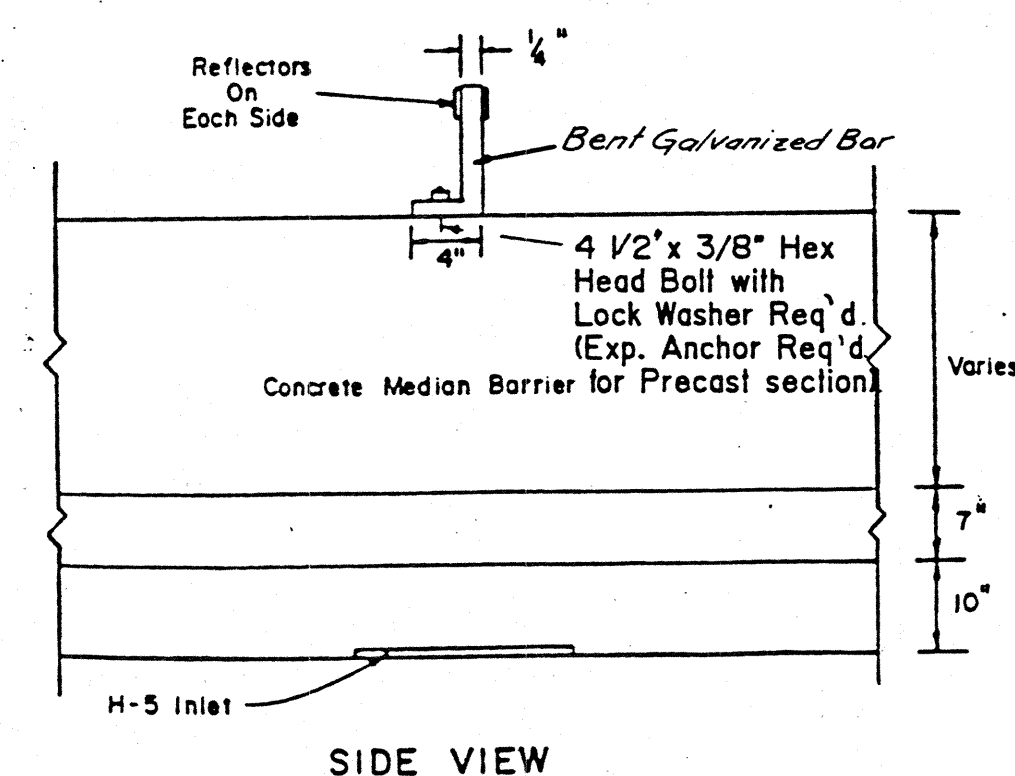

PLACEMENT OF REFLECTORS AT MEDIAN INLETS (TYPE H-5)

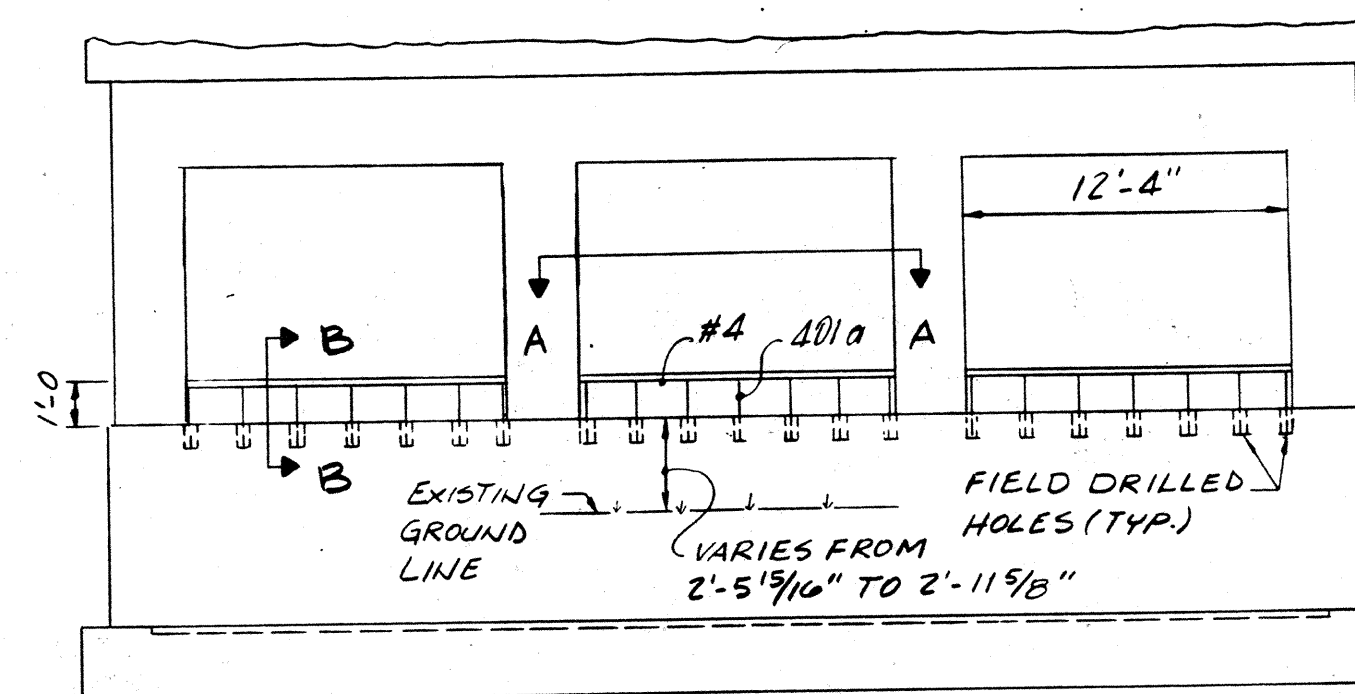
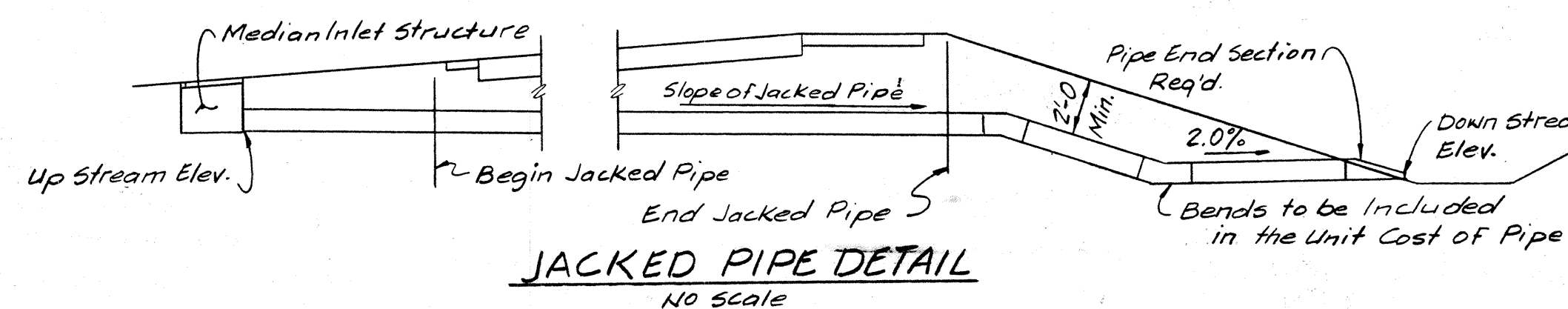

ELEVATIONS NO SCALE

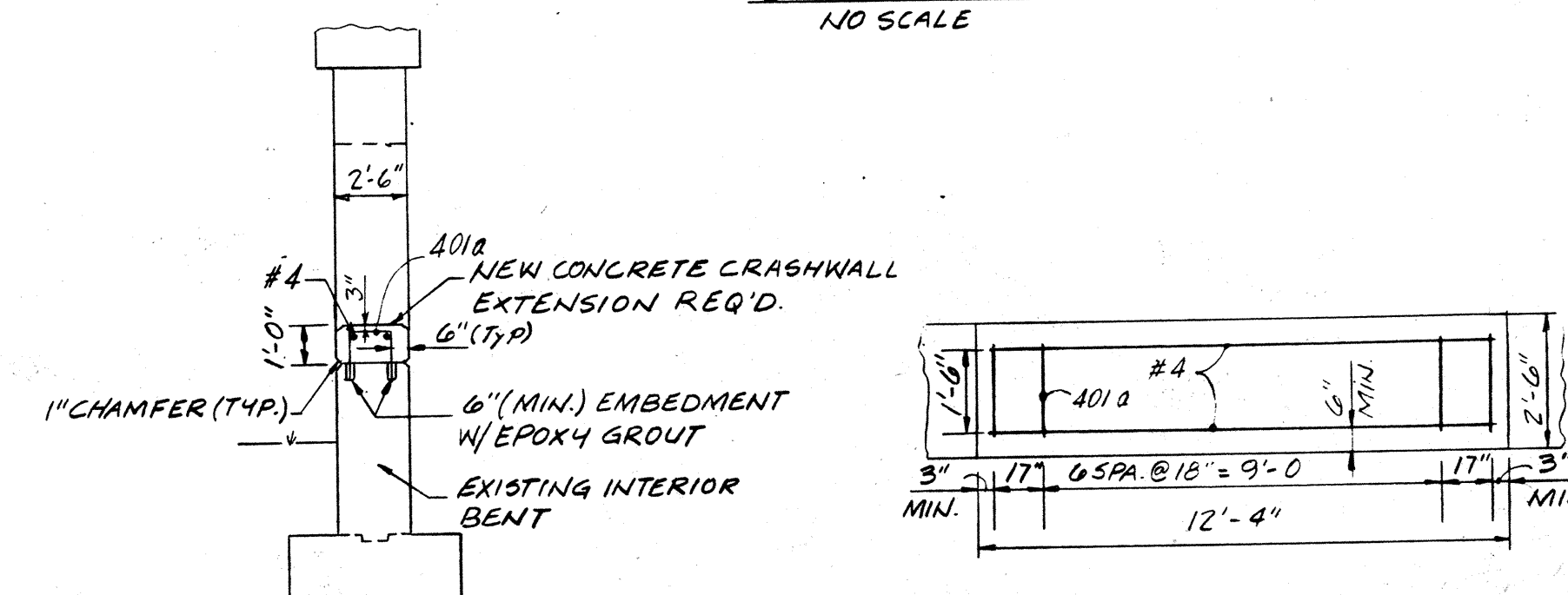

SECTION "B-B" NO SCALE

SECTION "A-A" NO SCALE

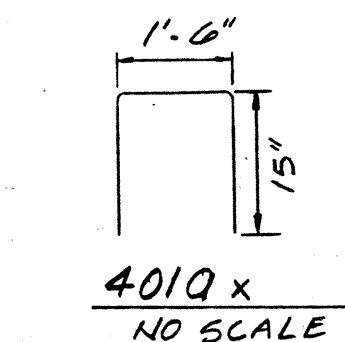

401Q x 15" NO SCALE

BILL OF MATERIALS			
EPOXY COATED REINFORCING STEEL			
SIZE & MARK	NO. OF BARS	LENGTH	WEIGHT
#401Q	36	4'-0"	96 LBS.
#4	6	12'-0"	48 LBS.
TOTAL REINF.			144 LBS.
CONCRETE			
"A" IN STRUCTURE			3.4 CYD.
MISCELLANEOUS			
DRILL FIELD HOLE IN CONCRETE			72

NOTES:
 - DRILL HOLES 1/8" LARGER THAN REBAR.
 - EPOXY GROUT REBAR INTO DRILLED HOLES.
 - USE CLASS "A" CONCRETE.
 - SEE BR. STD. C, FOR REINFORCING BAR NOTES.

CRASHWALL EXTENSION AT MEDIAN BENT OF CO. RD. 1000N BRIDGE OVER I-94

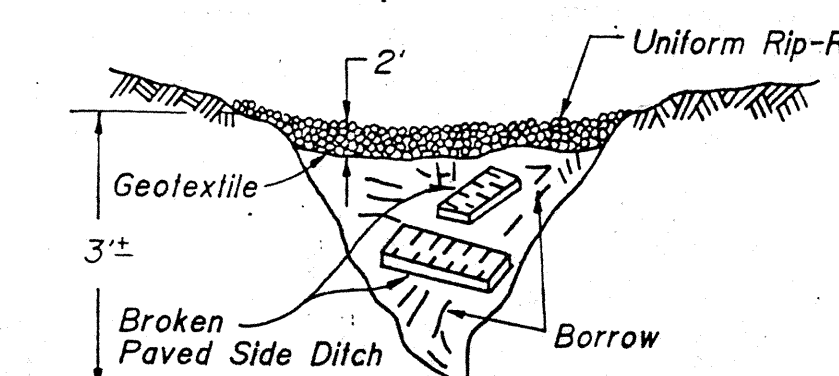

PAVED SIDE DITCH REMOVAL AND UNIFORM RIP-RAP DETAIL

DETAILS

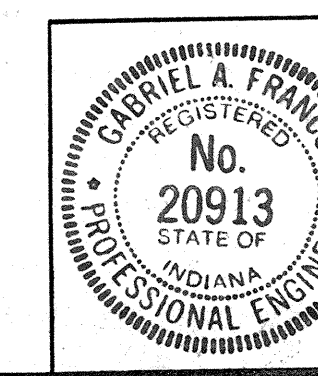

R-20060

FEDERAL ROAD REGION NO.	STATE	PROJECT NO.	FISCAL YEAR	SHEET NO.	TOTAL SHEETS
5	IND.	STI-94-2(2)9	1992	56	126

NOTES:

- ① All materials and workmanship shall be in accordance with the Special Provisions.
- ② Pipe and pipe fittings shall be 4" I.D. Schedule 40 PVC for Geocomposite Edge Drain and 6" I.D. Schedule 40 PVC for Standard Underdrain.
- ③ The openings in the wire mesh screen used in the temporary screened end cap shall be 1/4 inch square (4 openings per inch). The openings in the wire mesh screen used for the primary and secondary rodent screens shall be 1/3 inch square (3 openings per inch).
- ④ The screens for the temporary screened end cap and the secondary rodent screen shall be cut in a circular pattern with a diameter equivalent to the I.D. of the pipe fitting into which the screen is to be installed.
- ⑤ The primary rodent screen shall be the size and shape as shown on the details. It shall be fastened to the outlet protector with two 1/4 inch by one inch hex head lag screws with flat washers and anchors. The approximate location of the anchor holes shall be as shown on the details.
- ⑥ The delineator posts used to anchor the outlet protector shall be embedded a minimum of 2 feet. The exposed end of these delineator posts shall not protrude above the top edge of the downstream end of the outlet protector.
- ⑦ The slope of the outlet, from the outlet fitting to the downstream end of the outlet protector, shall be a minimum of 1/4" inch per foot.

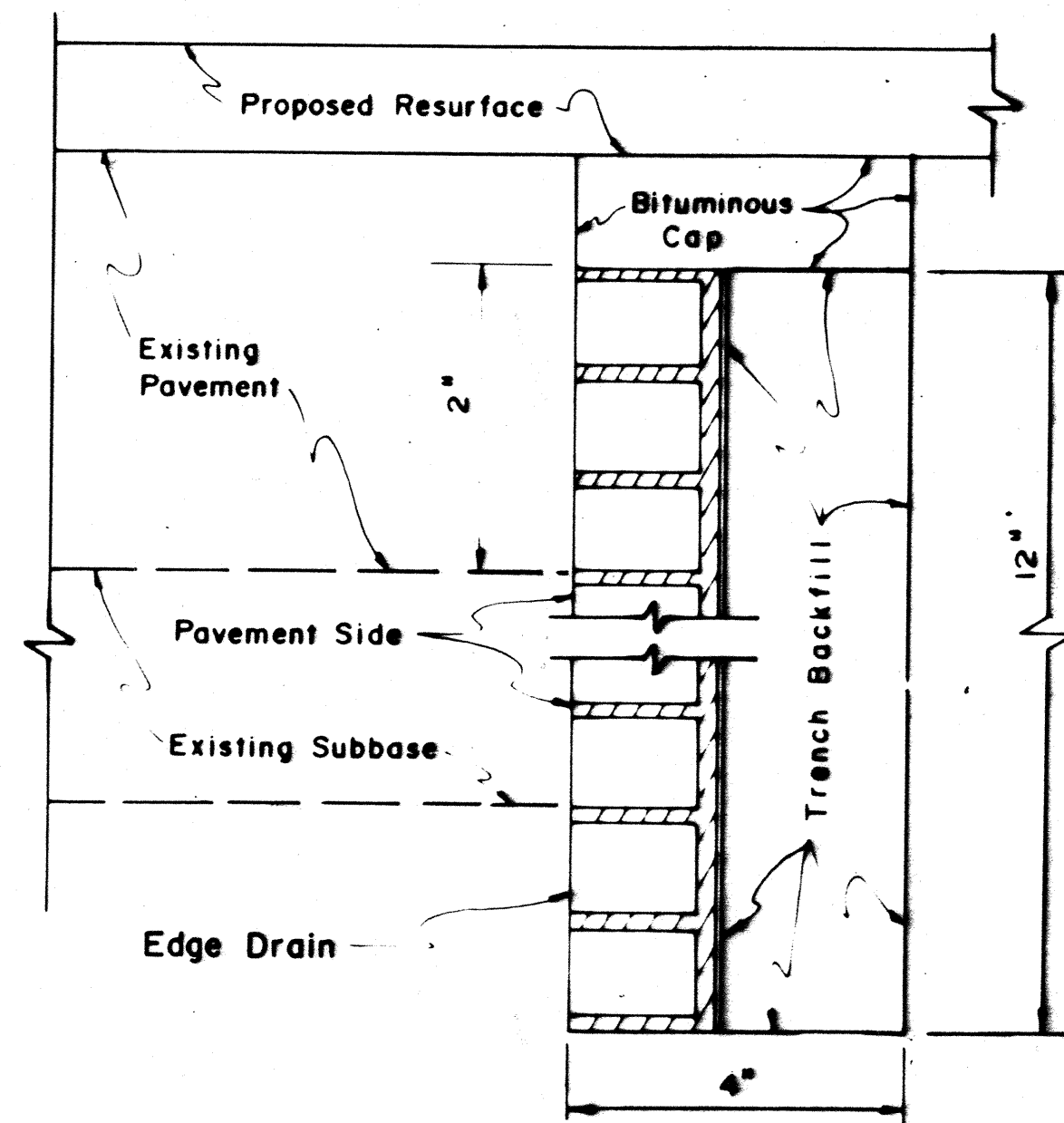

TRENCH DETAIL

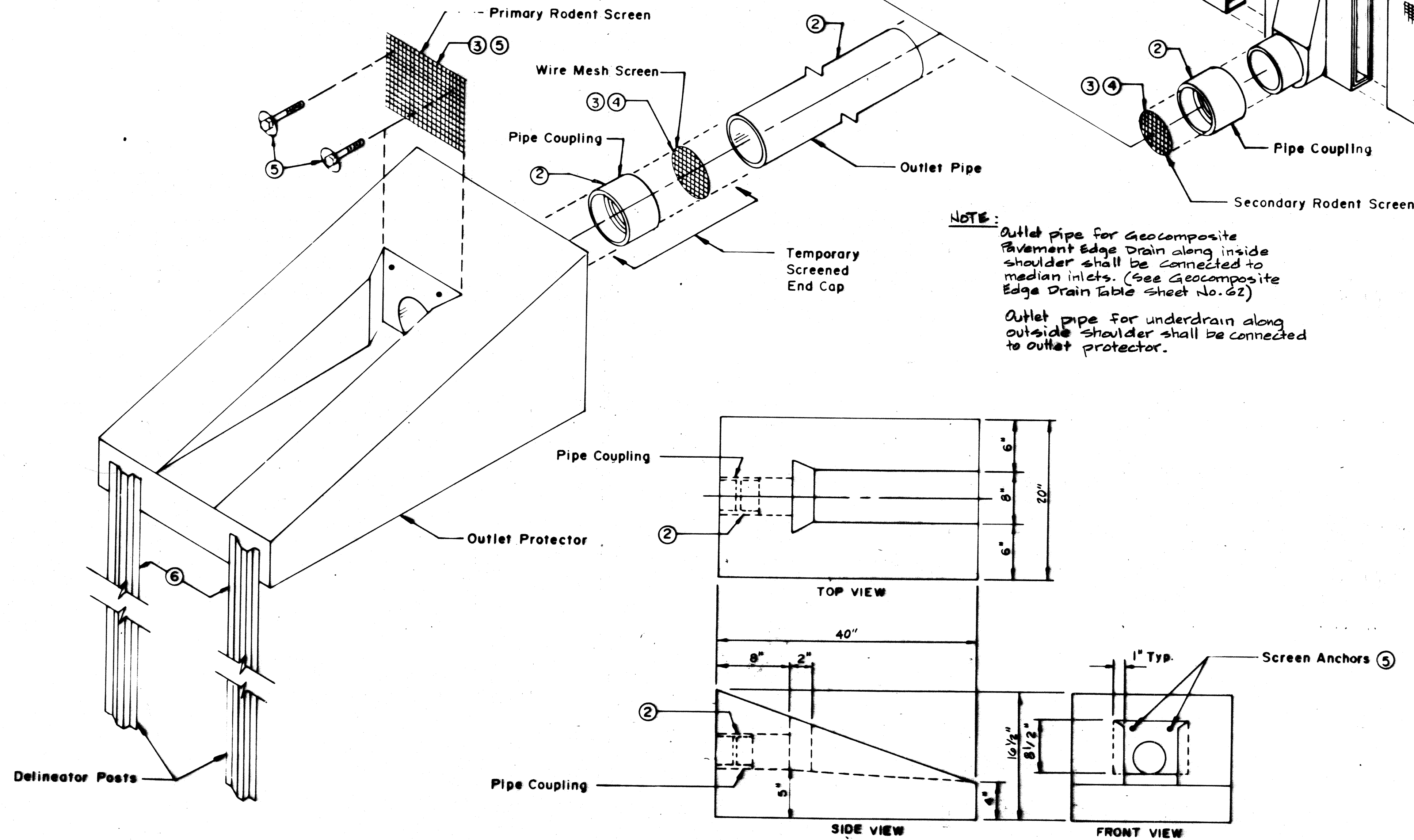
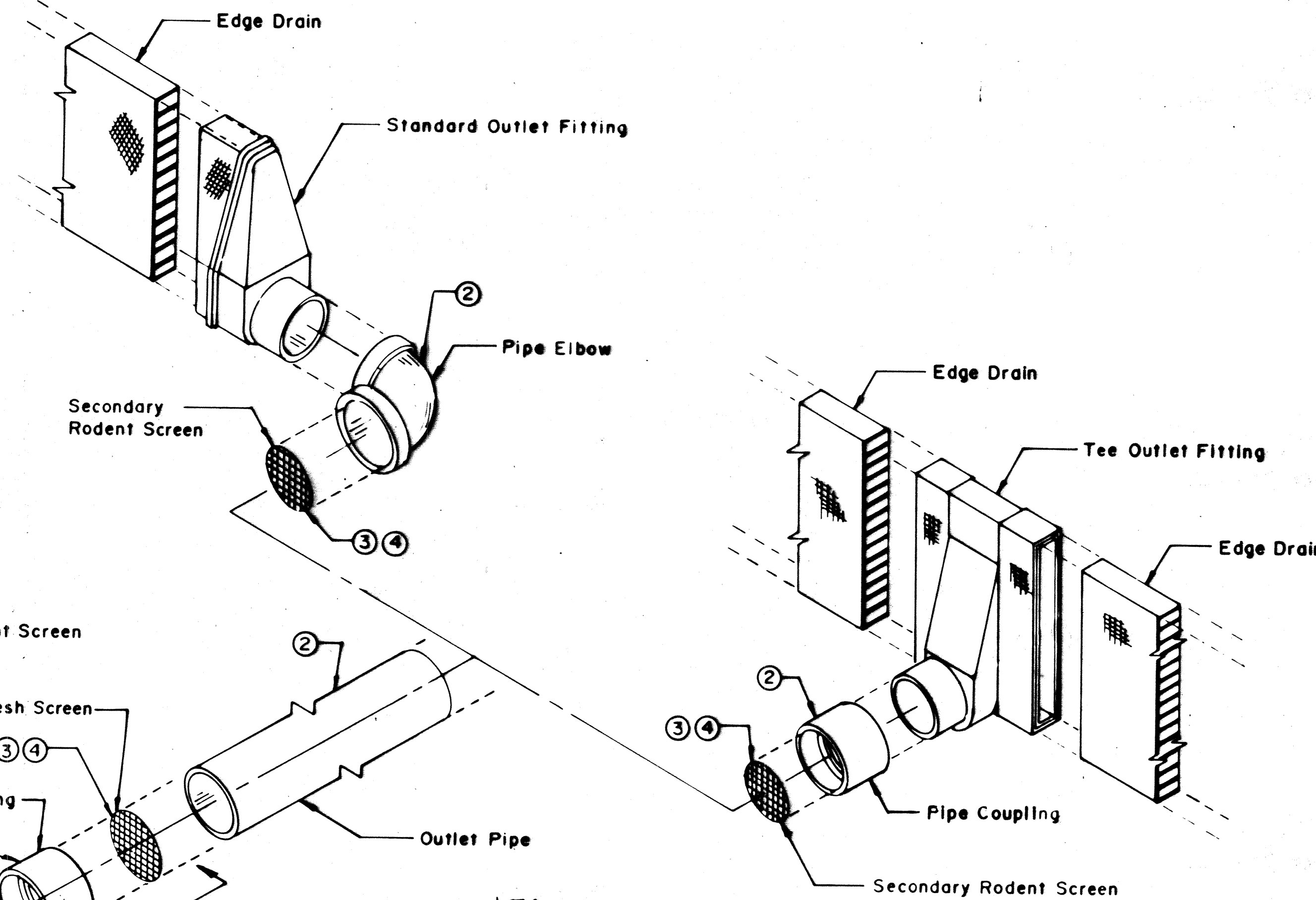

NOTE:
 Outlet pipe for Geocomposite Pavement Edge Drain along inside shoulder shall be connected to median inlets. (See Geocomposite Edge Drain Table Sheet No. 62)
 Outlet pipe for underdrain along outside shoulder shall be connected to outlet protector.

OUTLET PROTECTOR DETAIL FOR UNDERDRAIN ALONG OUTSIDE SHOULDER

GEOCOMPOSITE PAVEMENT EDGE DRAIN DETAILS



BY: MP

FEDERAL ROAD REGION NO.	STATE	PROJECT NO.	FISCAL YEAR	SHEET NO.	TOTAL SHEETS
5	IND.	STI-94-2()39	1992	65	126

REMOVAL OF GUARDRAIL					
STATION		LFT.			
FROM	TO	LT.	RT.	MED. LT.	MED. RT.
347+11	347+60	49			
346+55	348+27	172			
346+59	346+90		55		
349+90	352+50	260			
349+90	352+50		260		
366+83	368+30	147			
367+73	368+28	55			
363+12	368+25		513		
366+85	368+20		135		
369+90	371+28	138			
369+85	374+23	438			
369+83	370+15		32		
369+80	371+15		135		
382+15	384+10	195			
381+40	384+10			270	
381+40	384+10				270
380+64	385+15		451		
384+80	385+15	35			
384+80	385+15	35			
385+80	387+20	140			
385+80	388+15	235			
385+80	386+10		30		
385+80	386+10		30		
458+80	359+15	35			
458+80	359+15	35			
456+80	359+15		235		
457+77	359+15		138		
460+70	466+25	555			
460+70	463+10	240			
460+70	461+00		30		
460+70	465+83		513		
477+20	480+20			300	
477+20	480+20				300
453+30	456+27			297	
453+30	456+27				297
630+15	633+27			312	
630+15	633+27				312
668+20	672+30		410		
670+75	672+10		135		
672+07	672+45	38			
672+32	672+70	38			
674+20	675+55	135			
674+00	678+15	415			
673+85	674+23		38		
673+65	674+03		38		
4+15 "NWL"	7+30 "NWL"	315			
	SUBTOTAL	3,705	3,178	1,179	1,179
				TOTAL:	9,241 LFT.

REMOVAL OF GUARDRAIL TABLE

7017D105 BY:JT

* Indicates that Only One Box is Req'd.
Lt. or Rt. of the Median Barrier. (See Plans)

Note: All Pipe to be F.B.C.C.S.
unless Noted

STRUCTURE DATA

FEDERAL ROAD REGION NO.	STATE	PROJECT NO.	FISCAL YEAR	SHEET NO.	TOTAL SHEETS
5	IND.	STI-94-21 139	1992	66	126

STRUCTURE NUMBER	LOCATION STATION LINE "B"	LEFT	RIGHT	MEDIAN	SIZE INCHES	DESCRIPTION	LENGTH FT.	SKEW	FLOW LINE				TOP OF GRADE ELEVATION RT.	B ¹ BORROW FOR STR. BACKFILL CU.YDS.	BACKFILL METHOD	GAGES OR THICKNESS		Slope of Jacked Pipe %	RIPRAP	PIPE END SECTION	G.B.E.S.	22'30" BENDS	REMARKS
									COVER	UP STREAM	DOWN STREAM	STREAM				STEEL	ALUM.						
1	345+46					Br. File I-94-44-2253																	Not in this Contract.
2	369+07					Br. File I-94-45-4487																	In Combination with Rd. Project. See Br. Project No. MIAM-94-2 (081)
3	385+49					Br. File I-94-45-4488																	In Combination with Rd. Project. See Br. Project No. IR-94-2 (11) 44
4	415+50					Br. File I-94-45-5758																	No Construction Req'd.
5	459+92					Br. File I-94-47-2254																	In Combination with Rd. Project. See Br. Project No. IR-94-2 (11) 44
6	479+60					Br. File I-94-47-4489																	No Construction Req'd.
7	554+90					Br. File I-94-50-4490																	No Construction Req'd.
8	631+80					Br. File I-94-50-4491																	No Construction Req'd.
9	673+15					Br. File I-94-50-2255																	In Combination with Rd. Project. See Br. Project No. MIAM-94-2 (081)
10						Not Used																	
11	350+00				15	Mod. Inlet H-5, Pipe	138'			662.71	647.50	669.08	25.6	A	0.25	4.00	1	2					Pipe Jacking Req'd. (Jack 64' & Trench 74' of Pipe) #
					12	& Slotted Drain Pipe	2d				667.85				0.064								
12	353+52	X			12	*Mod. Inlet H-5, Pipe	3'			658.71	663.52	0.9	A	0.064									Conn. to Exist. Pipe
					12	& Slotted Drain Pipe	12'								0.064								
13	355+15					Exist. Str.																	No Change Req'd.
14	357+50				15	Mod. Inlet H-5, Pipe	90			652.60	651.70	658.02	12.9	A	0.25	3.75	1						Pipe Jacking Req'd. (Jack 54' & Trench 36' of Pipe)
					12	& Slotted Drain Pipe	2d				656.88				0.064								
15	360+00				12	Inlet H-5, Pipe	3			652.15	655.23	0.4	A	0.064									Conn. to Exist. Pipe
					12	& Slotted Drain Pipe	2d				655.23				0.064								
16	362+48					Exist. Str.																	No Change Req'd.
17	364+00				15	Mod. Inlet H-5, Pipe	100			650.97	646.00	633.90	10.1	A	0.25	4.00	1						Pipe Jacking Req'd. (Jack 60' & Trench 40' of Pipe)
					12	& Slotted Drain Pipe	2d				653.90				0.064								
18	367+00					Exist. Str.																	No Change Req'd.
19	367+92				12	Inlet H-5, Pipe	3			649.73	632.97	0.5	A	0.064									Conn. to Exist. Pipe
					12	& Slotted Drain Pipe	2d				652.97				0.064								
20	373+50				15	Inlet H-5, Pipe	90			645.60	641.80	649.12	9.0	A	0.25	4.00	1						Pipe Jacking Req'd. (Jack 54' & Trench 36' of Pipe)
					12	& Slotted Drain Pipe	2d				649.12				0.064								
21	377+02				12	Inlet H-5, Pipe	3			640.76	644.10	0.5	A	0.064									Conn. to Exist. Pipe
					12	& Slotted Drain Pipe	2d				644.10				0.064								
22	381+00				15	Inlet H-5, Pipe	105			631.81	631.81	637.83	G.B.	A	0.25	3.70	1						Pipe Jacking Req'd. (Jack 80' & Trench 25' of Pipe)
					12	& Slotted Drain Pipe	2d				637.83				0.064								
23	384+83				12	Inlet H-5, Pipe	3			630.07	633.24	0.5	A	0.064									Conn. to Exist. Pipe
					12	& Slotted Drain Pipe	2d				633.24				0.064								
24	386+10				12	Mod. Inlet H-5, Pipe	86			630.50	630.12	633.07	7.6	A	0.064								Conn. to Str. 25
											633.07												
25	387+00				12	Inlet H-5, Pipe	3			630.12	633.24	0.4	A	0.064									Conn. to Exist. Pipe
					12	& Slotted Drain Pipe	2d				633.24				0.064								
26	389+50				18	Inlet H-5, Pipe	86			632.73	630.00	635.79	B.B.	A	0.25	4.00	1						Pipe Jacking Req'd. (Jack 54' & Trench 32' of Pipe)
					12	& Slotted Drain Pipe	2d				635.79				0.064								
27	394+00				15	Inlet H-5, Pipe	150			640.00	632.73	643.07	61.2	A	0.064								Conn. to Str. 26
					12	& Slotted Drain Pipe	2d				643.07				0.064								
28	403+00				12	Inlet H-5, Pipe	3			654.20	657.73	0.6	A	0.064									Conn. to Exist. Pipe
					12	& Slotted Drain Pipe	2d				657.73				0.064								
29	407+00				18	Mod. Inlet H-5, Pipe	98			657.75	655.00	664.05	10.5	A	0.25	2.30	1						Pipe Jacking Req'd. (Jack 54' & Trench 44' of Pipe)
					12	& Slotted Drain Pipe	2d				664.05				0.064								

STRUCTURE NUMBER	LOCATION	LEFT	RIGHT	MEDIAN	SIZE INCHES	DESCRIPTION	LENGTH FT.	SKEW	FLOW LINE				TOP OF GRADE ELEVATION RT.	B ¹ BORROW FOR STR. BACKFILL CU.YDS.	BACKFILL METHOD	GAGES OR THICKNESS		Slope of Jacked Pipe %	RIPRAP	PIPE END SECTION	G.B.E.S.	22'30" BENDS	REMARKS
									COVER	UP STREAM	DOWN STREAM	STREAM				STEEL	ALUM.						
30	407+25					Exist. Str.																	36" Type I G.B.E.S. (3:1) Req'd. Lt. & Rt.
31	409+06					Exist. Str.																	No Change Req'd.
32	411+00				18	Mod. Inlet H-5, Pipe	396			662.50	657.75	669.61	26.4	A	0.064								Connect to Str. 29
											669.61												
33	415+00				15	Mod. Inlet H-5, Pipe	396			668.15	663.00	674.24	200.2	A	0.064								Connect to Str. 32
					12	& Slotted Drain Pipe	308				673.14				0.064								
34	415+20					Exist. Str.																	36" Type II G.B.E.S. (3:1) Req'd. Rt.
35	415+80					Exist. Str.																	36" Type II G.B.E.S. (3:1) Req'd. Lt.
36	427+50				15	Inlet H-5, Pipe	90			669.97	669.25	673.69	11.8	A	0.25	0.80	1						Pipe Jacking - Req'd. (Jack 54' & Trench 36' of Pipe)
					12	& Slotted Drain Pipe	112				673.65				0.064								
37	434+10				36	Mod. Inlet H-5, Pipe	8			658.22	665.92	3.9	A	0.064									36" Type I G.B.E.S. (4:1) Req'd. Lt. & Rt.
					12	& Slotted Drain Pipe	2d				665.92				0.064								
38	437+01				12	Inlet H-5, Pipe	3			659.20	662.42	0.5	A	0.064									Conn. to Exist. Pipe
					12	& Slotted Drain Pipe	2d				662.42				0.064								
39	441+50				15	Inlet H-5, Pipe	81			652.92	652.08	657.09	9.2	A	0.25	0.50	1						Pipe Jacking Req'd. (Jack 54' & Trench 30' of Pipe)
					12	& Slotted Drain Pipe	2d				657.09				0.064								
40	444+80				12	Inlet H-5, Pipe	3			651.22	654.85	0.6	A	0.064									Conn. to Exist. Pipe
					12	& Slotted Drain Pipe	18				654.85				0.064								
41	445+63					Exist. Str.				646.45													36" Type I G.B.E.S. (3:1) Req'd. Lt. & Rt.
42	445+80				12	Inlet H-5, Pipe	15			651.26	647.4	655.13	3.4	A	0.064								Conn. to Exist. Pipe, One 90° Bend Req'd.
					12	& Slotted Drain Pipe	2d				655.13				0.064								
43	452+08					Exist. Str.																	No Change Req'd.
44	452+18				12	Inlet H-5, Pipe	3			663.63	667.06	0.5	A	0.064									Conn. to Exist. Pipe
					12	& Slotted Drain Pipe	2d				667.06				0.064								
45	457+18				12	Inlet H-5, Pipe	3			673.28	676.69	0.5	A	0.064									Conn. to Exist. Pipe
					12	& Slotted Drain Pipe	2d				676.69				0.064								
45-A	459+47					Exist. Str.																	No Change Req'd.
45-B	460+25					Exist. Str.																	No Change Req'd.
46	462+50				12	Inlet H-5, Pipe	3			673.54	676.93	0.5	A	0.064									Conn. to Exist. Pipe
					12	& Slotted Drain Pipe	2d				676.93				0.064								
47	463+50					Exist. Str.																	No Change Req'd.
48	467+49	X			12	*Inlet H-5, Pipe	3			663.89	666.80	0.5	A	0.064									Conn. to Exist. Pipe
					12	& Slotted Drain Pipe	12'																
49	471+00				15	Mod. Inlet H-5, Pipe	100			653.00	650.60	657.91	10.4	A	0.25	2.50	1						Pipe Jacking Req'd. (Jack 54' & Trench 46' of Pipe)

STRUCTURE DATA

* Indicates that Only One Box is Req'd.
Lt. or Rt. of the Median Barrier. (See Plans)

FEDERAL ROAD REGION NO.	STATE	PROJECT NO.	FISCAL YEAR	SHEET NO.	TOTAL SHEETS
5	IND.	STI-94-21 139	1992	67	126

STRUCTURE NUMBER	LOCATION	LEFT	RIGHT	MEDIAN	SIZE INCHES	DESCRIPTION	LENGTH FT.	SKEW	FLOW LINE			TOP OF GRATE ELEV.	BORROW FOR STR. BACKFILL CU.YDS.	BACKFILL METHOD	GAGES OR THICKNESS		Slope of Jacked Pipe %	RIPRAP	PIPE END SECTION	G.B.E.S.	22'30' BENDS	REMARKS
									UP STREAM	DOWN STREAM	COVER				STEEL	ALUM.						
									ELEV.	ELEV.	ELEV.				INCHES	INCHES						
NOTE: ALL PIPE TO BE F.B.C.C.S. UNLESS NOTED.																						
51	173+00	X			12	*Inlet H-5, Pipe & Slotted Drain Pipe	3				651.36	652.21	0.4	A	0.064							Conn. to Exist. Pipe
52	176+00	X			12	*Inlet H-5, Pipe & Slotted Drain Pipe	12				648.11	648.00	10.8	A	0.064							Cement Conc. Pavement For Patching Req'd.
53	177+77	X			12	*Inlet H-5, Pipe & Slotted Drain Pipe	3				647.56		0.6	A	0.064							Conn. to Exist. Pipe
54	180+00	X			12	*Inlet H-5, Pipe & Slotted Drain Pipe	189				645.91	645.50	10.4	A	0.25	0.50						Pipe Jacking Req'd. (Jack 54' & Trench 34' of Pipe)
55	183+00	X			12	*Inlet H-5, Pipe & Slotted Drain Pipe	21				646.16	649.12	0.3	A	0.064							Conn. to Exist. Pipe
56	183+50	X			12	*Mod. Inlet H-5, Pipe & Slotted Drain Pipe	12				644.88	644.00	13.1	A	0.25	1.00						Pipe Jacking Req'd. (Jack 54' & Trench 34' of Pipe)
57	187+00	X			12	*Inlet H-5, Pipe & Slotted Drain Pipe	21				646.05	648.60	0.3	A	0.064							Conn. to Exist. Pipe
58	188+50	X			12	*Mod. Inlet H-5, Pipe & Slotted Drain Pipe	12				643.13	643.00	17.0	A	0.25	0.50						Pipe Jacking Req'd. (Jack 54' & Trench 36' of Pipe)
59	189+50					Exist. Str.																36" Type I G.B.E.S. (3:1) Req'd. Lt. & Rt.
60	191+02	X			12	*Mod. Inlet H-5, Pipe & Slotted Drain Pipe	21				645.16	648.15	0.3	A	0.064							Conn. to Exist. Pipe
61	193+50	X			12	*Mod. Inlet H-5, Pipe & Slotted Drain Pipe	12				643.12	643.00	13.8	A	0.25	0.50						Pipe Jacking Req'd. (Jack 54' & Trench 30' of Pipe)
62	195+00	X			12	*Inlet H-5, Pipe & Slotted Drain Pipe	21				645.06	647.67	0.3	A	0.064							Conn. to Exist. Pipe
63	198+50	X			12	*Mod. Inlet H-5, Pipe & Slotted Drain Pipe	12				643.11	643.00	12.5	A	0.25	0.50						Pipe Jacking Req'd. (Jack 54' & Trench 30' of Pipe)
64	199+00	X			12	*Inlet H-5, Pipe & Slotted Drain Pipe	21				644.51	647.49	0.4	A	0.064							Conn. to Exist. Pipe
65	503+00	X			12	*Inlet H-5, Pipe & Slotted Drain Pipe	21				644.21	647.93	0.4	A	0.064							Conn. to Exist. Pipe
66	503+50	X			12	*Mod. Inlet H-5, Pipe & Slotted Drain Pipe	21				642.39	641.80	10.4	A	0.25	0.50						Pipe Jacking Req'd. (Jack 54' & Trench 24' of Pipe)
67	506+50					Exist. Str.																19"x33" Type I G.B.E.S. (3:1) - Req'd. Lt. & Rt.
68	506+59				12	Inlet H-5, Pipe & Slotted Drain Pipe	21				643.97	647.77	1.1	A	0.064							Conn. to Exist. 12" CMP
69	510+33					Exist. Str.		21°														No Change Req'd.
70	511+00				12	Inlet H-5, Pipe & Slotted Drain Pipe	21				646.01	648.97	0.5	A	0.064							Conn. to Exist. Pipe
71	515+00				15	Mod. Inlet H-5, Pipe & Slotted Drain Pipe	21				645.00	644.55	12.6	A	0.25	0.50						Pipe Jacking Req'd. (Jack 62' & Trench 26' of Pipe)
72	518+14				12	Inlet H-5, Pipe & Slotted Drain Pipe	21				648.21	651.49	0.9	A	0.064							Conn. to Exist. Pipe
73	521+00				15	Mod. Inlet H-5, Pipe & Slotted Drain Pipe	24				648.50	646.89	12.3	A	0.25	1.50						Pipe Jacking Req'd. (Jack 72' & Trench 33' of Pipe)
74	523+99				12	Inlet H-5, Pipe & Slotted Drain Pipe	21				650.21	653.63	0.6	A	0.064							Conn. to Exist. Pipe

STRUCTURE NUMBER	LOCATION	LEFT	RIGHT	MEDIAN	SIZE INCHES	DESCRIPTION	LENGTH FT.	SKEW	FLOW LINE			TOP OF GRATE ELEV.	BORROW FOR STR. BACKFILL CU.YDS.	BACKFILL METHOD	GAGES OR THICKNESS		Slope of Jacked Pipe %	RIPRAP	PIPE END SECTION	G.B.E.S.	22'30' BENDS	REMARKS
									UP STREAM	DOWN STREAM	COVER				STEEL	ALUM.						
									ELEV.	ELEV.	ELEV.				INCHES	INCHES						
75	527+90				15	Inlet H-5, Pipe & Slotted Drain Pipe	21				650.95	649.00	14.0	A	0.25	3.00						Pipe Jacking Req'd. (Jack 54' & Trench 42' of Pipe)
76	532+02				12	Inlet H-5, Pipe & Slotted Drain Pipe	18				651.91	655.22	0.6	A	0.064							Conn. to Exist. Pipe
77	538+06				12	Inlet H-5, Pipe & Slotted Drain Pipe	18				651.78	655.07	0.6	A	0.064							Conn. to Exist. Pipe
78	541+50				15	Inlet H-5, Pipe & Slotted Drain Pipe	18				650.85	649.00	15.2	A	0.25	3.00						Pipe Jacking Req'd. (Jack 54' & Trench 41' of Pipe)
79	542+35				30	Pipe	16															30" Type II G.B.E.S. (10:1) Req'd. Rt. Conn. to Str. 80
80	542+85				19x33	Exist. Str.	8															Extend Exist. Pipe Rt.
81	542+55				30	Pipe	16															30" Type II G.B.E.S. (10:1) Req'd. Rt. Conn. to Str. 80
82	542+55					Exist. Str.																19"x33" Type I G.B.E.S. (13:1) Req'd. Lt.
83	544+49				12	Inlet H-5, Pipe & Slotted Drain Pipe	18				651.82	654.82	0.5	A	0.064							Conn. to Exist. Pipe
84	550+96				12	Inlet H-5, Pipe & Slotted Drain Pipe	21				651.23	654.76	0.6	A	0.064							Conn. to Exist. Pipe
85	552+00				15	Inlet H-5, Pipe & Slotted Drain Pipe	18				650.61	650.00	12.6	A	0.25	0.70						Pipe Jacking Req'd. (Jack 54' & Trench 36' of Pipe)
86	557+00				12	Inlet H-5, Pipe & Slotted Drain Pipe	18				651.53	655.18	0.7	A	0.064							Conn. to Exist. Pipe
87	559+50				15	Inlet H-5, Pipe & Slotted Drain Pipe	21				651.63	649.00	13.1	A	0.25	2.70						Pipe Jacking Req'd. (Jack 54' & Trench 41' of Pipe)
88	562+70					Exist. Str.																36" Type I G.B.E.S. (3:1) Req'd. Lt. & Rt.
89	564+00				12	Mod. Inlet H-5, Pipe & Slotted Drain Pipe	21				653.89	656.56	0.4	A	0.064							Conn. to Exist. Pipe
90	567+00				15	Inlet H-5, Pipe & Slotted Drain Pipe	21				653.00	652.75	12.7	A	0.25	0.50						Pipe Jacking Req'd. (Jack 54' & Trench 32' of Pipe)
91	572+00					Exist. Str.																36" Type I G.B.E.S. (1:1) Req'd. Lt. & Rt.
92	572+11				12	Mod. Inlet H-5, Pipe & Slotted Drain Pipe	24				655.08	654.88	653.60	3.3	A	0.064						Conn. to Str. 91
93	577+95					Exist. Str.																36" Type I G.B.E.S. (2:1) Req'd. Lt. & Rt.
94	580+00				12	Inlet H-5, Pipe & Slotted Drain Pipe	21				660.66	664.54	0.8	A	0.064							Conn. to Exist. Pipe
95	583+00				15	Inlet H-5, Pipe & Slotted Drain Pipe	21				662.71	661.42	666.56	11.8	A	0.25	0.80					Pipe Jacking Req'd. (Jack 54' & Trench 33' of Pipe)

LEGEND FOR ABBREVIATION

F.B.C.C.S./R.I.--FULLY BITUMINOUS COATED CORRUGATED STEEL WITH PAVED INVERT.	F.B.C.S.A./R.I.--FULLY BITUMINOUS COATED CORRUGATED STEEL ARCH WITH PAVED INVERT.
F.B.C.C.A.A./P.I.--FULLY BITUMINOUS COATED CORRUGATED ALUMINUM ALLOY WITH PAVED INVERT.	F.B.C.C.A.A./R.I.--FULLY BITUMINOUS COATED CORRUGATED ALUMINUM ARCH WITH PAVED INVERT.
F.B.C.C.S.-----FULLY BITUMINOUS COATED CORRUGATED STEEL.	F.B.C.C.A.-----FULLY BITUMINOUS COATED CORRUGATED STEEL ARCH.
C.S.-----CORRUGATED STEEL.	F.B.C.C.A.A.-----FULLY BITUMINOUS COATED CORRUGATED ALUMINUM ARCH.
C.A.A.-----CORRUGATED ALUMINUM	C.S.A.-----CORRUGATED STEEL ARCH.
S.P.S.-----STRUCTURAL PLATE STEEL	C.A.A.-----CORRUGATED ALUMINUM ARCH.
G.B.E.S.-----GRATED BOX END SECTION	S.P.S.A.-----STRUCTURAL PLATE STEEL ARCH.
S-----STEEL	

± For Jacked Pipe Detail See Sheet No. 55

R-20060

STRUCTURE DATA

FEDERAL ROAD REGION NO.	STATE	PROJECT NO.	FISCAL YEAR	SHEET NO.	TOTAL SHEETS
5	IND.	ST-94-21-139	1992	68	120

STRUCTURE NUMBER	LOCATION	LEFT	RIGHT	MEDIAN	SIZE INCHES	DESCRIPTION	LENGTH FT.	SKEW	FLOW LINE			TOP OF GRATE	FT. BORROW FOR STR. BACKFILL	BACKFILL METHOD	GAGES OR THICKNESS		Slope of Jacked Pipe	RIPRAP	PIPE END SECTION	G.B.E.S.	22-30' BENDS	REMARKS	
									UP STREAM	DOWN STREAM	COVER				STEEL	ALUM.							
									ELEV.	ELEV.	ELEV.				INCHES	INCHES							
NOTE: ALL PIPE TO BE F.B.C.C.S. UNLESS NOTED.																							
96	590+00				15	Inlet H-5, Pipe & Slotted Drain Pipe	92			667.21	665.90	671.02	13.0	A	0.25	0.80	1					Pipe Jacking - Req'd. (Jack 54' & Trench 38' of Pipe)	
97	597+00				15	Mod. Inlet H-5, Pipe & Slotted Drain Pipe	92			671.21	670.50	675.56	13.4	A	0.25	0.80	1					Pipe Jacking - Req'd. (Jack 54' & Trench 38' of Pipe)	
98	601+00					Exist. Str.																18" Type I G.B.E.S. (1:1) - Req'd. Lt. & Rt.	
99	601+11				12	Inlet H-5, Pipe & Slotted Drain Pipe	10			676.21		680.01	2.5	A	0.064							Conn. to Str. 98	
100	611+50				15	Inlet H-5, Pipe & Slotted Drain Pipe	39			679.56	676.36	682.32	54.8	A	0.064							Connect to Str 101	
101	618+50				15	Inlet H-5, Pipe & Slotted Drain Pipe	96			676.36	675.50	680.78	10.1	A	0.25	0.80	1					Pipe Jacking - Req'd. (Jack 54' & Trench 42' of Pipe)	
102	623+50					Exist. Str.																36" Type I G.B.E.S. (6:1) - Req'd. Lt. & Rt.	
103	624+00				15	Mod. Inlet H-5, Pipe & Slotted Drain Pipe	97			672.99	672.50	678.83	10.4	A	0.25	0.80	1					Pipe Jacking - Req'd. (Jack 54' & Trench 48' of Pipe)	
104	626+00				12	Inlet H-5, Pipe & Slotted Drain Pipe	3			674.71		678.21	0.6	A	0.064							Conn. to Exist. Pipe	
105	629+50					Exist. Str.																36" Type I G.B.E.S. (6:1) - Req'd. Lt. & Rt.	
106	630+00				15	Mod. Inlet H-5, Pipe & Slotted Drain Pipe	93			671.97	671.50	677.07	16.0	A	0.25	0.80	1					Pipe Jacking - Req'd. (Jack 54' & Trench 39' of Pipe)	
107	631+10				12	Mod. Inlet H-5, Pipe & Slotted Drain Pipe	3			671.96		676.72	1.1	A	0.064							Conn. to Exist. Pipe	
108	635+00				12	Inlet H-5, Pipe & Slotted Drain Pipe	3			673.35		677.04	0.7	A	0.064							Conn. to Exist. Pipe	
109	637+00				15	Mod. Inlet H-5, Pipe & Slotted Drain Pipe	90			672.15	672.00	677.04	12.9	A	0.25	0.80	1					Pipe Jacking - Req'd. (Jack 54' & Trench 36' of Pipe)	
110	641+51				12	Mod. Inlet H-5, Pipe & Slotted Drain Pipe	3			672.39		677.19	1.1	A	0.064							Conn. to Exist. Pipe	
111	644+50				15	Mod. Inlet H-5, Pipe & Slotted Drain Pipe	95			673.90	671.80	677.34	12.3	A	0.25	2.00	1					Pipe Jacking - Req'd. (Jack 54' & Trench 41' of Pipe)	
112	648+02				12	Mod. Inlet H-5, Pipe & Slotted Drain Pipe	3			673.11		677.54	0.9	A	0.064							Conn. to Exist. Pipe	
113	649+02					Exist. Str.																36" Type I G.B.E.S. (1:1) - Req'd. Lt. & (6:1) Req'd. Rt. †	
114	651+52				12	Inlet H-5, Pipe & Slotted Drain Pipe	3			671.10		677.94	0.7	A	0.064							Conn. to Exist. Pipe	
115	656+00				15	Mod. Inlet H-5, Pipe & Slotted Drain Pipe	95			673.90	672.00	678.24	14.1	A	0.25	2.00	1					Pipe Jacking - Req'd. (Jack 54' & Trench 41' of Pipe)	
116	660+01				12	Inlet H-5, Pipe & Slotted Drain Pipe	3			677.29		680.78	0.7	A	0.064							Conn. to Exist. Pipe	
117	665+00				15	Inlet H-5, Pipe & Slotted Drain Pipe	130			686.00	673.50	690.17	26.8	A	0.25	1.00	1					Pipe Jacking - Req'd. (Jack 54' & Trench 76' of Pipe) ††	
118	670+31				12	Mod. Inlet H-5, Pipe & Slotted Drain Pipe	3			696.53		700.43	0.8	A	0.064							Conn. to Exist. Pipe	
118A	671+00					Exist. Str.																No Change Req'd.	
119	675+51				12	Inlet H-5, Pipe & Slotted Drain Pipe	3			697.15		700.81	0.6	A	0.064							Conn. to Exist. Pipe	

STRUCTURE NUMBER	LOCATION	LEFT	RIGHT	MEDIAN	SIZE INCHES	DESCRIPTION	LENGTH FT.	SKEW	FLOW LINE			TOP OF GRATE	FT. BORROW FOR STR. BACKFILL	BACKFILL METHOD	GAGES OR THICKNESS		Slope of Jacked Pipe	RIPRAP	PIPE END SECTION	G.B.E.S.	22-30' BENDS	REMARKS	
									UP STREAM	DOWN STREAM	COVER				STEEL	ALUM.							
									ELEV.	ELEV.	ELEV.				INCHES	INCHES							
120	678+00				15	Inlet H-5, Pipe & Slotted Drain Pipe	150			694.00	672.50	698.09	30.1	A	0.25	2.00	1					Pipe Jacking - Req'd. (Jack 54' & Trench 96' of Pipe) †	
121	3+00 "B.W.C."					Exist. Str.																No Change Req'd.	
122	10+50 "B.W.C."					Exist. Str.																No Change Req'd.	
123	3+15 "S.W.I."					Exist. Str.																No Change Req'd.	
124	3+00 "N.W.C."					Exist. Str.																36" Type I G.B.E.S. (3:1) Lt. & (3:1) Rt. Req'd.	
125	12+35 "N.W.C."					Exist. Str.																36" Type I G.B.E.S. (3:1) Req'd. Lt. & Rt.	
126	2+50 "N.W.I."				36	F.B.C.C.S. Pipe	6					0.6	B	0.064								Extend Exist. Pipe 6' Lt.	
127	10+18 "S.E.C."				36	F.B.C.C.S. Pipe	18					1.9	B	0.064								Extend Exist. Pipe 18' Rt.	
128	15+93 "S.E.C."					Exist. Str.																36" Type I G.B.E.S. (3:1) Lt. & (5:1) Rt. Req'd.	
129	2+50 "S.E.L."				36	F.B.C.C.S. Pipe	18					1.9	B	0.064								Extend Exist. Pipe 8' Lt. & 10' Rt.	
130	12+00 "N.E.C."					Exist. Str.																No Change Req'd.	
131	14+50 "N.E.C."				36	F.B.C.C.S. Pipe	14					1.4	B	0.064								Extend Exist. Pipe 14' Lt.	
132	8+15 "N.E.L."				36	F.B.C.C.S. Pipe	15					1.5	B	0.064								Remove 3' of Exist. Pipe Rt. Extend Pipe 6' Lt. & 9' Rt.	
133	4+100 "S-4-B"					Exist. Str.																No Change Req'd.	
134	45+00 "S-4-B"					Exist. Str.																No Change Req'd.	
135	43+00 "S-4-B"					Exist. Str.																No Change Req'd.	
136	52+10 "S-4-B"					Exist. Str.																No Change Req'd.	
137	57+50 "S-4-B"					Exist. Str.																No Change Req'd.	
											TOTAL	1101.8											
											USE	1100											

LEGEND FOR ABBREVIATION

F.B.C.C.S./R.I.--FULLY BITUMINOUS COATED CORRUGATED STEEL WITH PAVED INVERT.	F.B.C.S.A./R.I.--FULLY BITUMINOUS COATED CORRUGATED STEEL ARCH WITH PAVED INVERT.
F.B.C.C.A.A./R.I.--FULLY BITUMINOUS COATED CORRUGATED ALUMINUM ALLOY WITH PAVED INVERT.	F.B.C.C.A.A./R.I.--FULLY BITUMINOUS COATED CORRUGATED ALUMINUM ARCH WITH PAVED INVERT.
F.B.C.C.S.--FULLY BITUMINOUS COATED CORRUGATED STEEL.	F.B.C.C.A.--FULLY BITUMINOUS COATED CORRUGATED STEEL ARCH.
C.S.--CORRUGATED STEEL.	F.B.C.C.A.A.--FULLY BITUMINOUS COATED CORRUGATED ALUMINUM ARCH.
C.A.A.--CORRUGATED ALUMINUM	C.S.A.--CORRUGATED STEEL ARCH.
S.P.S.--STRUCTURAL PLATE STEEL	C.A.A.--CORRUGATED ALUMINUM ARCH.
G.B.E.S.--GRATED BOX END SECTION	S.P.S.A.--STRUCTURAL PLATE STEEL ARCH.
S-----STEEL	

†For Jacked Pipe Detail See Sheet No. 55