

INDIANA
DEPARTMENT OF TRANSPORTATION

CONTRACT INFORMATION
BOOK (CIB)

PART I

CONTRACT NO. _____

LETTING DATE: _____

Certified By: _____

Date: _____

*Covering Items in Table of Contents, PART I
For Release for Bidding Purposes*

CONTRACT INFORMATION
TABLE OF CONTENTS

CONTRACT NO.

This book shall be examined to determine that each page set out in the Contract Information Table of Contents, and the Special Provisions Table of Contents is attached, legible, and current.

<u>PART I</u>	PAGES
PROPOSAL PAGE	1
SCHEDULE OF PAY ITEMS	1 -
RECURRING PLAN DETAILS	1 -
TRAFFIC CONTROL DEVICE REPORT	1
SPECIAL PROVISIONS	1 -

PART II

CONTACT FOR CONTRACTORS

*

DISTRICT CONSTRUCTION ENGINEER:

***QUESTION FORM**

Contractors shall submit contract specific questions by completing the Question Form accessed from <http://entappsqa.indot.in.gov/cqa/>. The Department will attempt to have an answer on-line within two business days.

Retrieve the Question and Answer Form for a specific contract by going on-line in the same manner you retrieve Contract Information Books and Plans. <https://netservices.indot.in.gov/ViewDocs2.0/> will display the interface used for selection of contract letting documents. For the document category, select "Q and A Form".

CONTACTS FOR DISTRICT PERSONNEL ONLY

PHONE:

PHONE:

PROPOSAL
TO THE
INDIANA DEPARTMENT OF TRANSPORTATION

DATE OF LETTING: August 06, 2014

TIME OF LETTING: 10:00 AM EASTERN DAYLIGHT SAVING TIME

LOCATION OF LETTING: N725 CONF RM, GOVERNMENT CENTER NORTH
100 N. SENATE AVENUE
INDIANAPOLIS, INDIANA 46204

LOCATION OF DEPOSIT: N725 GOVERNMENT CENTER NORTH
100 N. SENATE AVENUE
INDIANAPOLIS, INDIANA 46204

***** STATE CERTIFIED *****

CONTRACT NUMBER: RS-35321-A

PROJECT NUMBER(S): 1297609

STRUCTURE NUMBER(S):

ROUTE: SR 135

LOCATION: ON SR 135 FROM SR 64 TO US 150

DESCRIPTION: ASPHALT RESURFACE

SEYMOUR DISTRICT

COUNTY : HARRISON

CONTRACT COMPLETION INFORMATION

CONTRACT COMPLETION DATE:

October 31, 2014

DBE GOAL: A contract provision goal of 6 percent of the contract bid price has been established as the minimum amount for contracting to disadvantaged business enterprises.

THE FOLLOWING DOCUMENTS ARE INCLUDED IN THE CONTRACT:

2014 STANDARD SPECIFICATIONS EFFECTIVE

LIST OF APPROVED OR PREQUALIFIED MATERIALS

STANDARD DRAWINGS LISTED ON STANDARD DRAWING INDEX EFFECTIVE 9-1-13

ADDITIONAL REFERENCE MATERIAL MAY BE AVAILABLE ON THE INDOT WEBSITE. THE REFERENCE MATERIAL MAY INCLUDE, BUT IS NOT LIMITED TO PERMITS, ASBESTOS REPORTS, GEOTECHNICAL REPORTS, AND PRE-BID QUESTIONS AND ANSWERS. THE CONTRACTOR SHALL CONSIDER THE AVAILABLE ADDITIONAL REFERENCE MATERIAL IN PREPARATION OF THE PROPOSAL BID.

INDIANA DEPARTMENT OF TRANSPORTATION
SCHEDULE OF PAY ITEMS

PAGE: 1

CONTRACT ID: RS-35321-A

LETTING DATE: August 06, 2014

REVISED:

CONTRACTOR : _____

LINE NO	ITEM DESCRIPTION	APPROX. QUANTITY AND UNITS	UNIT PRICE DOLLARS CTS	BID AMOUNT DOLLARS CTS

SECTION 0001 ASPHALT RESURFACE				

0001	105-06845 CONSTRUCTION ENGINEERING	LUMP	LUMP	.
0002	109-08359 LIQUIDATED DAMAGES	1.000 DOL	1.00000	1.00
0003	109-08360 CONTRACT LIENS	1.000 DOL	1.00000	1.00
0004	109-08440 QUALITY ADJUSTMENTS, HMA	1.000 DOL	1.00000	1.00
0005	109-08443 QUALITY ADJUSTMENTS, TEMPORARY TRAFFIC CONTROL DEVICES	1.000 DOL	1.00000	1.00
0006	109-08444 QUALITY ADJUSTMENTS, FAILED MATERIALS	1.000 DOL	1.00000	1.00
0007	109-09377 QUALITY ADJUSTMENT, PAVEMENT TRAFFIC MARKINGS	1.000 DOL	1.00000	1.00
0008	109-09489 PAYMENT ADJUSTMENT, PG ASPHALT BINDER	1.000 DOL	1.00000	1.00
0009	110-01001 MOBILIZATION AND DEMOBILIZATION	LUMP	LUMP	.
0010	202-02278 CURB, CONCRETE, REMOVE	10.000 LFT	.	.

INDIANA DEPARTMENT OF TRANSPORTATION
SCHEDULE OF PAY ITEMS

PAGE: 2

CONTRACT ID: RS-35321-A

LETTING DATE: August 06, 2014
REVISED:

CONTRACTOR : _____

LINE NO	ITEM DESCRIPTION	APPROX. QUANTITY AND UNITS	UNIT PRICE DOLLARS CTS	BID AMOUNT DOLLARS CTS
0011	202-52710 SIDEWALK, CONCRETE, REMOVE	10.000 SYS	. 	.
0012	304-07491 HMA PATCHING, TYPE C	200.000 TON	. 	.
0013	306-08034 MILLING, ASPHALT, 1 1/2 IN	10206.000 SYS	. 	.
0014	306-08042 MILLING, SCARIFICATION	111076.000 SYS	. 	.
0015	306-08432 MILLING, APPROACH	3000.000 SYS	. 	.
0016	401-07328 QC/QA-HMA, 3, 70, SURFACE, 9.5 mm	842.000 TON	. 	.
0017	401-10258 JOINT ADHESIVE, SURFACE	6850.000 LFT	. 	.
0018	401-11785 LIQUID ASPHALT SEALANT	6850.000 LFT	. 	.
0019	406-05520 ASPHALT FOR TACK COAT	3.000 TON	. 	.
0020	414-11468 ULTRATHIN BONDED WEARING COURSE, 9. 5 mm	111076.000 SYS	. 	.
0021	604-06070 SIDEWALK, CONCRETE	10.000 SYS	. 	.

INDIANA DEPARTMENT OF TRANSPORTATION
SCHEDULE OF PAY ITEMS

PAGE: 3

CONTRACT ID: RS-35321-A

LETTING DATE: August 06, 2014
REVISED:

CONTRACTOR : _____

LINE NO	ITEM DESCRIPTION	APPROX. QUANTITY AND UNITS	UNIT PRICE		BID AMOUNT	
			DOLLARS	CTS	DOLLARS	CTS
0022	604-07901 CURB RAMP, CONCRETE, G	78.000 SYS	.		.	
0023	605-01870 CURB, CONCRETE, A	10.000 LFT	.		.	
0024	606-07484 MILLED HMA CORRUGATIONS	86045.000 LFT	.		.	
0025	610-07488 HMA FOR APPROACHES, TYPE C	250.000 TON	.		.	
0026	621-06574 SODDING	10.000 SYS	.		.	
0027	628-09402 FIELD OFFICE, B	6.000 MOS	.		.	
0028	628-11730 CELLULAR TELEPHONE TYPE B	2.000 EACH	.		.	
0029	628-11732 CELLULAR TELEPHONE ADDITIONAL MINUTES	1.000 DOL	1.00000			1.00
0030	628-11780 CELLULAR TELEPHONE SERVICE 500 MIN	12.000 MOS	.		.	
0031	801-03290 CONSTRUCTION SIGN, C	10.000 EACH	.		.	
0032	801-06207 TEMPORARY PAVEMENT MARKING, REMOVABLE, 4 IN	4000.000 LFT	.		.	

INDIANA DEPARTMENT OF TRANSPORTATION
SCHEDULE OF PAY ITEMS

PAGE: 4

CONTRACT ID: RS-35321-A

LETTING DATE: August 06, 2014
REVISED:

CONTRACTOR : _____

LINE NO	ITEM DESCRIPTION	APPROX. QUANTITY AND UNITS	UNIT PRICE		BID AMOUNT	
			DOLLARS	CTS	DOLLARS	CTS
0033	801-06640 CONSTRUCTION SIGN, A	55.000 EACH	.		.	
0034	801-06775 MAINTAINING TRAFFIC	LUMP	LUMP		.	
0035	805-78470 SIGNAL CABLE, ROADWAY LOOP, COPPER 1C/14GA	6000.000 LFT	.		.	
0036	805-78510 SIGNAL CABLE, DETECTOR LEAD-IN COPPER 2C/16GA	600.000 LFT	.		.	
0037	805-78785 SIGNAL DETECTOR HOUSING	14.000 EACH	.		.	
0038	805-78795 SAW CUT FOR ROADWAY LOOP AND SEALANT	1920.000 LFT	.		.	
0039	808-04298 PAVEMENT MESSAGE MARKING, THERMOPLASTIC, (RXR)	4.000 EACH	.		.	
0040	808-05929 TRANSVERSE MARKING THERMOPLASTIC, CROSSWALK LINE, 8"	390.000 LFT	.		.	
0041	808-06705 LINE, THERMOPLASTIC, SOLID, WHITE, 8 IN	2050.000 LFT	.		.	
0042	808-06711 LINE, PAINT, BROKEN, WHITE, 4 IN	1730.000 LFT	.		.	
0043	808-06712 LINE, PAINT, BROKEN, YELLOW, 4 IN	5506.000 LFT	.		.	

INDIANA DEPARTMENT OF TRANSPORTATION
SCHEDULE OF PAY ITEMS

PAGE: 5

CONTRACT ID: RS-35321-A

LETTING DATE: August 06, 2014
REVISED:

CONTRACTOR : _____

LINE NO	ITEM DESCRIPTION	APPROX. QUANTITY AND UNITS	UNIT PRICE DOLLARS CTS	BID AMOUNT DOLLARS CTS
0044	808-06713 LINE, PAINT, SOLID, WHITE, 4 IN	64062.000 LFT	.	.
0045	808-06714 LINE, PAINT, SOLID, YELLOW, 4 IN	30677.000 LFT	.	.
0046	808-09381 RETRO-REFLECTIVITY TESTING	LUMP	LUMP	.
0047	808-75272 TRANSVERSE MARKING, THERMOPLASTIC, CROSSHATCH LINE, WHITE, 24"	662.000 LFT	.	.
0048	808-75290 TRANSVERSE MARKING, THERMOPLASTIC, CROSSHATCH LINE, YELLOW, 24"	600.000 LFT	.	.
0049	808-75297 TRANSVERSE MARKING, THERMOPLASTIC, STOP LINE, 24 IN	275.000 LFT	.	.
0050	808-75320 PAVEMENT MESSAGE MARKING, THERMOPLASTIC, LANE INDICATION ARROW	20.000 EACH	.	.
0051	808-75325 PAVEMENT MESSAGE MARKING, THERMOPLASTIC, (ONLY)	13.000 EACH	.	.
0052	808-75996 SNOWPLOWABLE RAISED PAVEMENT MARKER, REMOVE	630.000 EACH	.	.
0053	808-92027 LINE, THERMOPLASTIC, SOLID, YELLOW, 8"	2960.000 LFT	.	.
	SECTION 0001 TOTAL			.
	TOTAL BID			.

INDIANA DEPARTMENT OF TRANSPORTATION
SCHEDULE OF PAY ITEMS

PAGE: 6

CONTRACT ID: RS-35321-A

LETTING DATE: August 06, 2014
REVISED:

CONTRACTOR : _____

LINE NO	ITEM DESCRIPTION	APPROX. QUANTITY AND UNITS	UNIT PRICE DOLLARS CTS	BID AMOUNT DOLLARS CTS
------------	---------------------	----------------------------------	-----------------------------	-----------------------------

103-C-584d DBE JOINT CHECK REQUEST FORM

(Adopted 04-15-14)

INDIANA DEPARTMENT OF TRANSPORTATION DBE JOINT CHECK REQUEST FORM

Name of DBE

Contract Number

Name of Prime Contractor

Item Number(s)

Name of Material Supplier

Who Requested Joint Check Utilization

DBE

Prime Contractor

Material Supplier

INDOT will closely monitor the use of joint checks. To receive DBE credit for performing a commercially useful function with respect to obtaining materials and supplies, a DBE must “be responsible for negotiating price, determining quality and quantity, ordering the material and installing (where applicable) and paying for the material itself.” Only when a DBE meets all of these requirements should credit be counted for the procurement of the items by the DBE. Please refer to the attached *Procedures for Using Joint Checks under the Disadvantaged Business Program* for qualifying conditions. If proper procedures are not followed or INDOT determines that the arrangement results in lack of independence for the DBE involved, no credit for the DBE’s participation as it relates to the material cost will be counted toward the contract goal requirement.

I have read and understand the above information and have attached a copy of the Joint Check Agreement relating to this request. I hereby acknowledge that the information provided on this form is true and accurate.

Authorized DBE Representative		
Signature	Title	Date

Authorized Prime Contractor Representative		
Signature	Title	Date

Authorized Material Supplier Representative		
Signature	Title	Date

INDOT USE ONLY	
Date Received:	INDOT Representative:
<input type="checkbox"/> Approved <input type="checkbox"/> Denied	<i>Note: Do not process this request without a signed copy (all parties) of the Joint Check Agreement, statement of history, and any related policies.</i>
Comments:	

Please send the DBE Joint Check Request Form to INDOT’s Economic Opportunity Division

**INDIANA DEPARTMENT OF TRANSPORTATION
PROCEDURES FOR USING JOINT CHECKS UNDER THE DISADVANTAGED BUSINESS
ENTERPRISE (DBE) PROGRAM**

A joint check is a “two party” check payable to two parties. Typically, a joint check is issued by a prime contractor to a subcontractor and to a material supplier or another third party for items or services to be incorporated into a project.

INDOT understands that prime contractors, subcontractors and suppliers may wish to use joint check arrangements for a variety of legitimate reasons, such as assuring that timely payment will be for the supplier’s items or dealing with situations in which it is difficult for a subcontractor to obtain bonding at a competitive rate. However, INDOT also understands that the use of joint checks can raise questions about whether it is proper to count DBE credit for the items purchased using the joint check.

When joint checks are utilized, DBE credit toward the contract goal will only be allowed when the DBE is performing a “commercially useful function” in accordance with 49 CFR 26.55(c)(1):

“A DBE performs a commercially useful function when it is responsible for execution of the work of the contract and is carrying out its responsibilities by actually performing, managing, and supervising the work involved. To perform a commercially useful function, the DBE must also be responsible, with respect to the materials and supplies used on the contract, for negotiating price, determining quality and quantity, ordering the material, and installing (where applicable), and paying for the material itself.”

The following conditions will apply to payments to DBE subcontractors and material vendors using joint checks. INDOT will closely monitor the use of joint checks to ensure that such a practice does not erode the independence of the DBE nor inhibit the DBE’s ability to perform a commercially useful function. Joint checks will not be allowed simply for the convenience of the prime contractor. Failure to follow these conditions may disqualify DBE participation or adversely impact a contractor’s bidding status.

1. Any implementation of a Joint Check Agreement must first be approved by INDOT and requested by the DBE involved using the *DBE Joint Check Request Form* provided by INDOT;
2. A formalized Joint Check Agreement between the parties involved (including the conditions of the arrangement and expected use of the joint checks) must accompany the *DBE Joint Check Request Form*;
3. Each party to the Joint Check Agreement must also submit a statement of its history in using joint checks and any related policies with the *DBE Joint Check Request Form*;
4. Joint checks should be focused on accomplishing the procurement of materials needed for a particular purpose at a particular time (i.e., contract specific).
5. Even with joint checks, the DBE will remain responsible for the other elements of 49 CFR 26.55(c)(1);
6. No requirement by the prime contractor that the DBE is to use a specific supplier nor the prime contractors “negotiated” price;
7. DBE must release the joint check to the material supplier (upon determining that the material supplier or other third party has fulfilled its responsibilities under the contract);
8. DBEs must be more than an extra participant in releasing the check to the material supplier;
9. Prime contractors must make joint checks available to all contract participants, and may not be restrictive to any one participant; and
10. All parties involved in a formalized joint check agreement must provide INDOT (upon request) with any documentation deemed necessary to substantiate compliance.

Storm Water, Erosion, and Sediment Control Inspection Report

INDOT
(4-2012)

Part B: Additional Quantities or Additional BMPs Needed				
Any additional control quantities or new BMPs not shown on the SWPPP must be approved by the PE/PS. If multiple locations are involved, identify the exact location of each addition. Justification for the measure must be provided.				
BMP Type (see table on page 3)	Approximate Station		Survey Line: Left, Right or centerline	Description/Justification for the additional BMPs Along with description provide image filename here for any reference pictures provided.
	From	To		

Part C: Temporarily or Permanently Suspended Construction Activities				
Where construction activities (grading, excavating, embankment filling, or other land disturbing activities have been suspended either temporarily or permanently, describe why stabilization measures were not initiated within 7 days.				
BMP Type (see table on page 3)	Approximate Station		Survey Line: Left, Right or centerline	Description Along with description provide image filename here for any reference pictures provided.
	From	To		

Part D: Compliance Evaluation (check only one)	
<input type="checkbox"/>	With the maintenance and improvement actions noted, the areas inspected will meet the intent of the Erosion and Sediment Control Plan and INDOT contract documents and specifications related to temporary erosion and sediment control.
<input type="checkbox"/>	The areas inspected are not meeting the intent and are in potential noncompliance with the Erosion and Sediment Control Plan and/or INDOT contract documents and specifications related to temporary erosion and sediment control. There is off site sedimentation and/or a high potential for off-site sedimentation on this project. (If this box is checked, complete the following "Part E: Potential Noncompliance Issues" section of this form)

Part E: Potential Noncompliance Issues				
BMP Type (see table on page 3)	Approximate Station		Survey Line: Left, Right or centerline	Describe the potential noncompliance issue(s) e.g. failure to adequately inspect the project, repeated failure of a BMP, failure to install a required BMP, a visible off-site discharge of material (silt, sand, oily water, etc.), or potential off-site discharges or potential failures.
	From	To		

Storm Water, Erosion, and Sediment Control Inspection Report

INDOT
(4-2012)

Part F: Inspection Certification			
I certify that this document and all attachments were prepared under my direction or supervision in accordance with a system designed to assure that qualified personnel properly gather and evaluate the information submitted. Based on my inquiry of the person or persons who manage the system, or those persons directly responsible for gathering the information, the information submitted is to the best of my knowledge and belief, true, accurate, and complete.			
Inspector Name Printed:	Company:	Title:	Date:
Inspector Signature: _____			
If evaluating an inspection performed by another inspector, please check one of the following boxes: <input type="checkbox"/> I concur with the inspector <input type="checkbox"/> I do not concur with the inspector (please circle any findings that you do not agree with)			
Owner Representative Name:		Signature: _____	
Date: _____			
A permanent copy must be filed with the project records and be provided to INDOT or IDEM personnel according to requirements or upon request.			

Table of Types of Erosion and Sediment Control Best Management Practices (BMPs)							
1	Diversion Interceptor	8	Check Dam, Traversable	15	Filter Berm	22	Concrete Washout
2	Temporary Seeding	9	Slope Drain	16	Filter Sock	23	Secondary Spill Containment
3	Permanent Sod or Seed	10	Splash Pad	17	Turbidity Curtain	24	
4	Mulch (hydraulic or bonded fiber mulch)	11	Sediment Trap	18	Surface Roughening	25	
5	Straw Mulch (blown/laid)	12	Sediment Basin	19	Vegetative Filter Strip	26	
6	Manufactured Surface Protection Products	13	Retention Pond	20	Inlet Protection	27	
7	Check Dam	14	Silt Fence	21	Construction entrance/exit	28	

- cc: Prime Contractor Superintendent (add Prime Contractor Owner/President when appropriate)
 INDOT Project Engineer (add INDOT Area Engineer when appropriate)
 INDOT District E&SC Specialist (add INDOT Central Office E&SC Specialist when appropriate)

Storm Water, Erosion, and Sediment Control Inspection Report

INDOT
(4-2012)

Instructions for the Contractor's representative: Fill out this document completely including filling out the Project Information, Areas Inspected and Parts A, B, C, D, E and F the day of your field investigation and put it on file for the project. Submit the signed document to the INDOT project representative the same day. Always provide pictures to document site conditions observed in your report.

Instructions for INDOT's representative:

- When you receive a completed and signed inspection report as completed by the contractor, visit the site within 24 hours of receipt of the contractor's inspection to verify the contractor's findings. If you concur with the contractor's inspection, fill out part F and sign as the INDOT representative. If you don't concur with the contractor's inspection, fill out parts E, F and circle any areas where you believe the inspection misrepresented the site's state of compliance with the intent of INDOT standards. If possible, provide pictures to document site conditions observed. Upon completion, sign under Part F, put it on file with the project and copy the prime contractor's representative.
- If you are completing this as an evaluation of an INDOT project without regard to the contractor's inspection, fill out all parts of the form including part D, E and sign as the inspector in part F. Always provide pictures to document site conditions observed in your report. Provide a copy to the INDOT PE/PS for the project and the Area Engineer. It is recommended that the inspection report be provided to the contractor immediately for their information (not their concurrence). It is also recommended another INDOT rep. visit the site within 24 hours to verify the inspection for their records and sign concurrence or non-concurrence in Part F.

Additional Explanation:

- Part A – Only put BMPs in Part A that were deemed to be in need of maintenance or alteration. Do not provide a list of every BMP inspected on the project. The intent is to document only those which were deemed in need of maintenance or alteration in order to continue to meet the intent of the measure at the location.
- Part B – Only put additional BMPs not yet installed on the project site in Part B. These can be BMPs intended for a different construction phase of the project or BMPs planned for other areas of the project that make sense to be deployed at additional locations. This is also where recommendations of measures would occur that identify new BMPs not in the contract documents.
- Part C – This is a list of known bare/exposed areas of the project and the justification why they are remaining bare or exposed during the review period despite a lack of construction activities. This especially includes any areas that are or are planned to be exposed for greater than 7 days without immediate plans to stabilize.
- Part D – Checking that the project is not in compliance with the intent of INDOT standards indicates that despite the additional maintenance measures and BMPs, the project's oversight is failing to ensure that sediment is prevented from leaving the project site or has the potential to leave the project site.
- Part E – List principles of storm water or erosion and sediment control that appear to be lacking on the project which demonstrate the lack of oversight of the project by qualified personnel.
- Part F – The "I certify" signature of the inspector is important in order to document whose opinion is being provided by the filling out of this form.

Speeding
Max \$1000
Reckless Driving
Max 8 Yrs

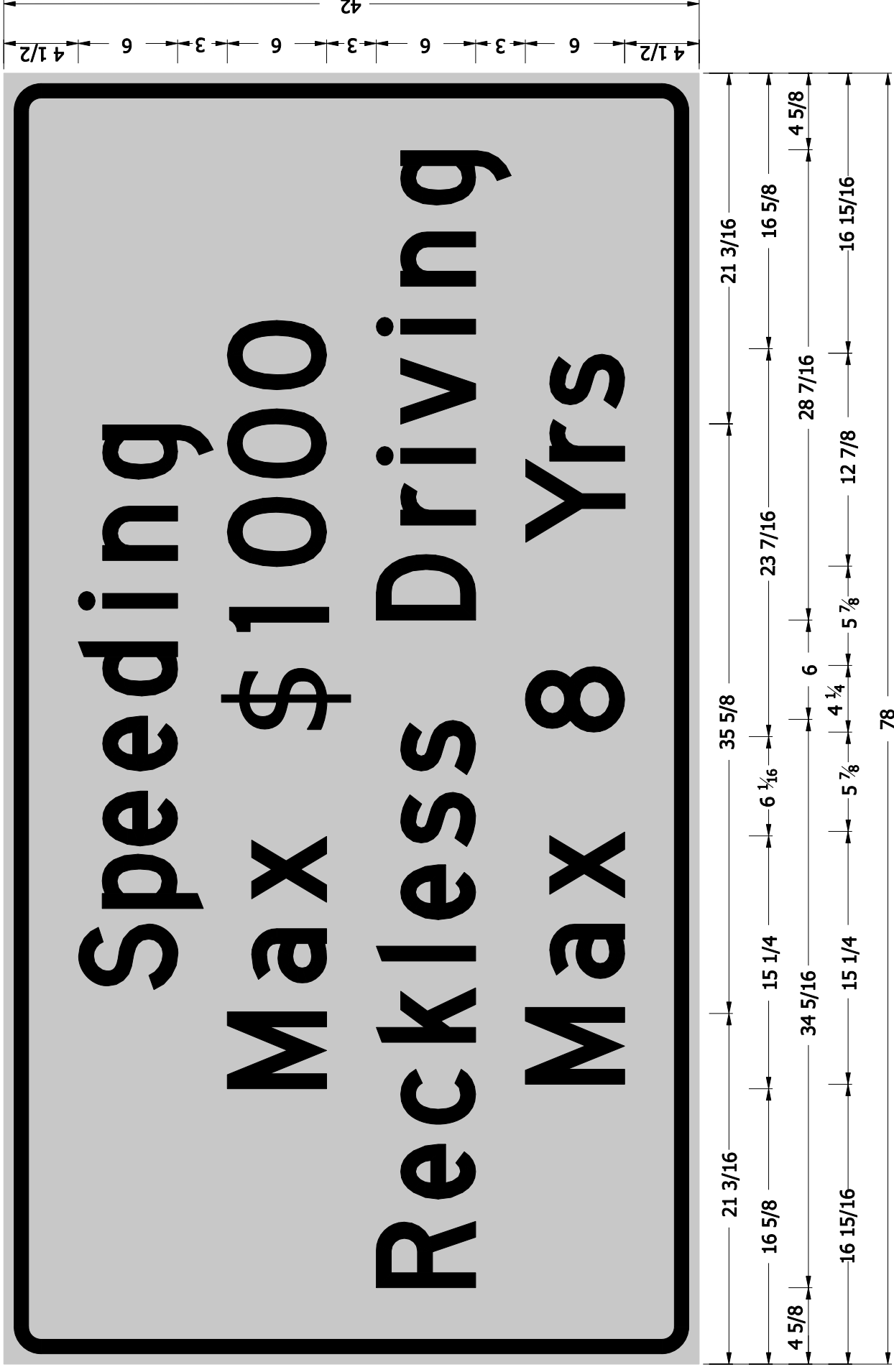

6 D UPPER AND LOWER; 2.250" Radius, 0.875" Border, 0.625" Indent, Black on Orange;
 [Speeding] D; [Max \$1000] D; [Reckless Driving] D; [Max 8 Yrs] D;

XG 20-7

INDIANA DEPARTMENT OF TRANSPORTATION

WORKSITE ADDED
 PENALTY SIGN 78 x 42

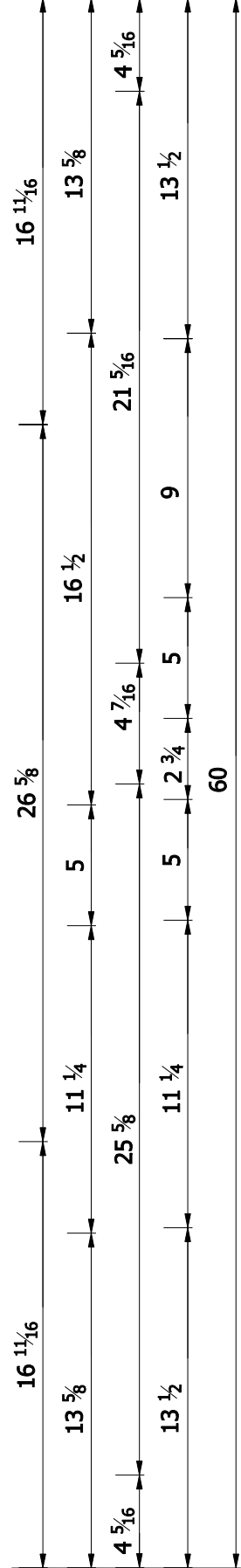
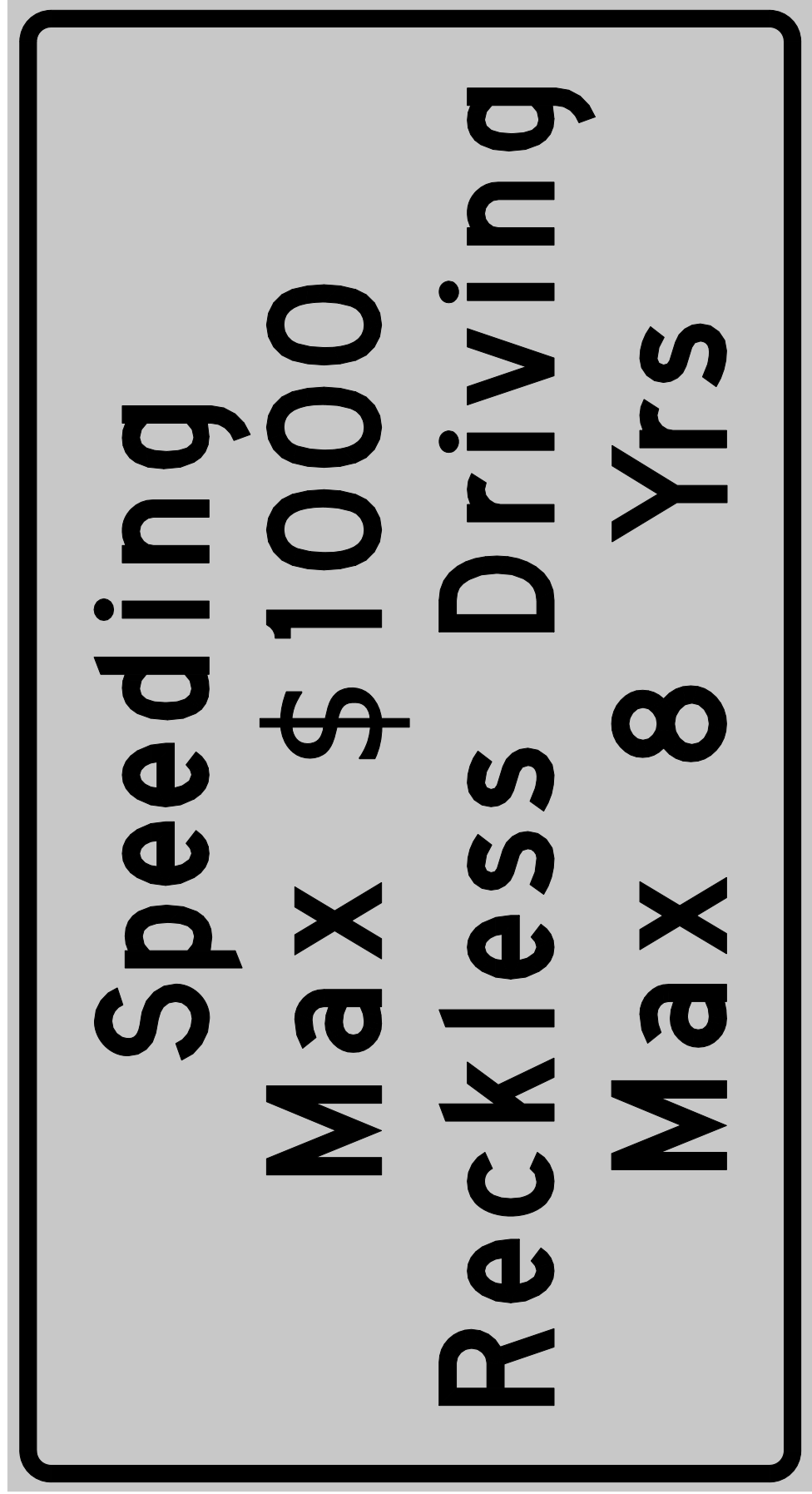
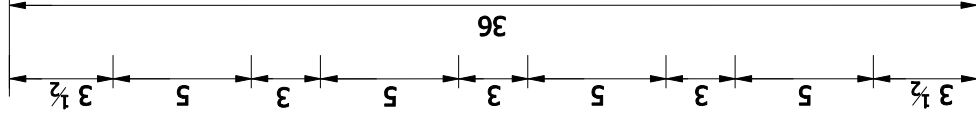

5 C UPPER AND LOWER; 2.250" Radius, 0.875" Border, 0.625" Indent, Black on Orange;
[Speeding] C; [Max \$1000] C; [Reckless Driving] C; [Max 8 Yrs] C;

XG 20-7a

INDIANA DEPARTMENT OF TRANSPORTATION

WORKSITE ADDED
PENALTY SIGN 60 x 36

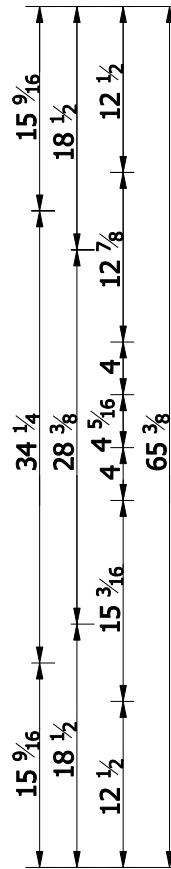
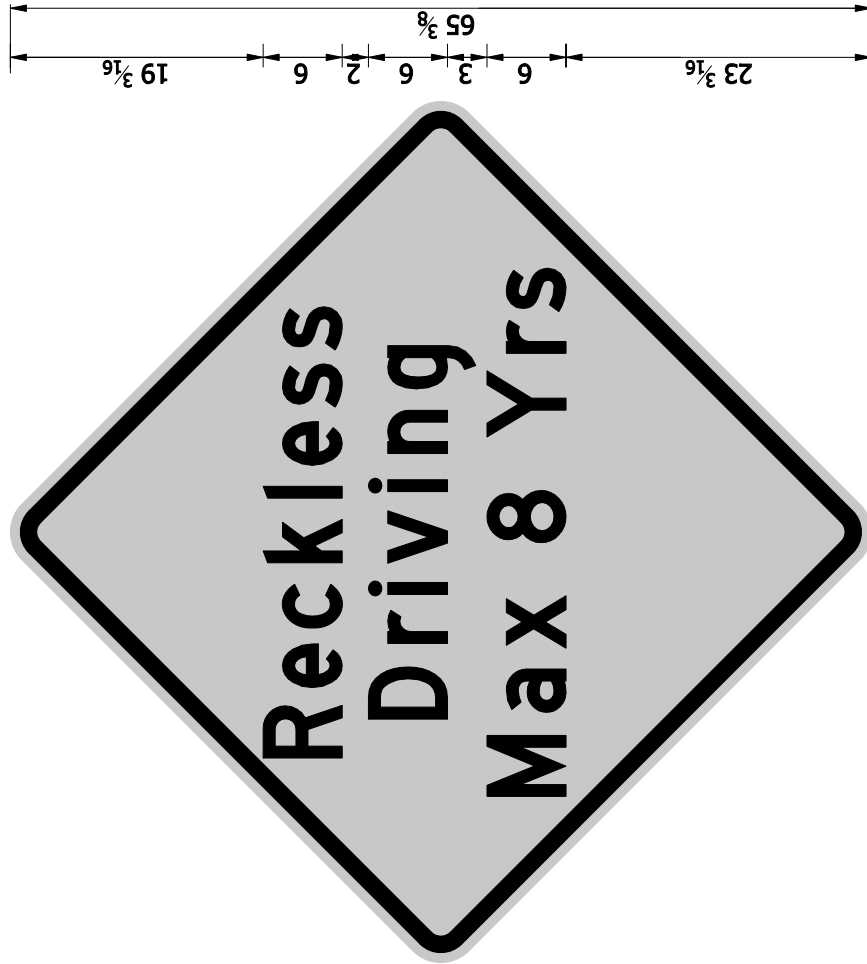

48x48 ; 6 D UPPER AND LOWER
48.000" across sides 3.000" Radius, 1.250" Border, 0.750" Indent, Black on Orange;
[Reckless] D; [Driving] D; [Max 8 Yrs] D;

XG20-7b

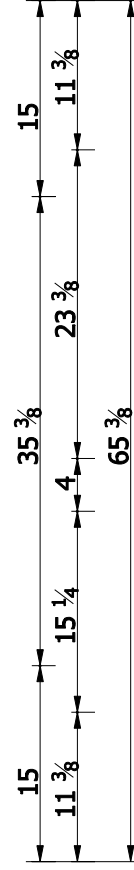
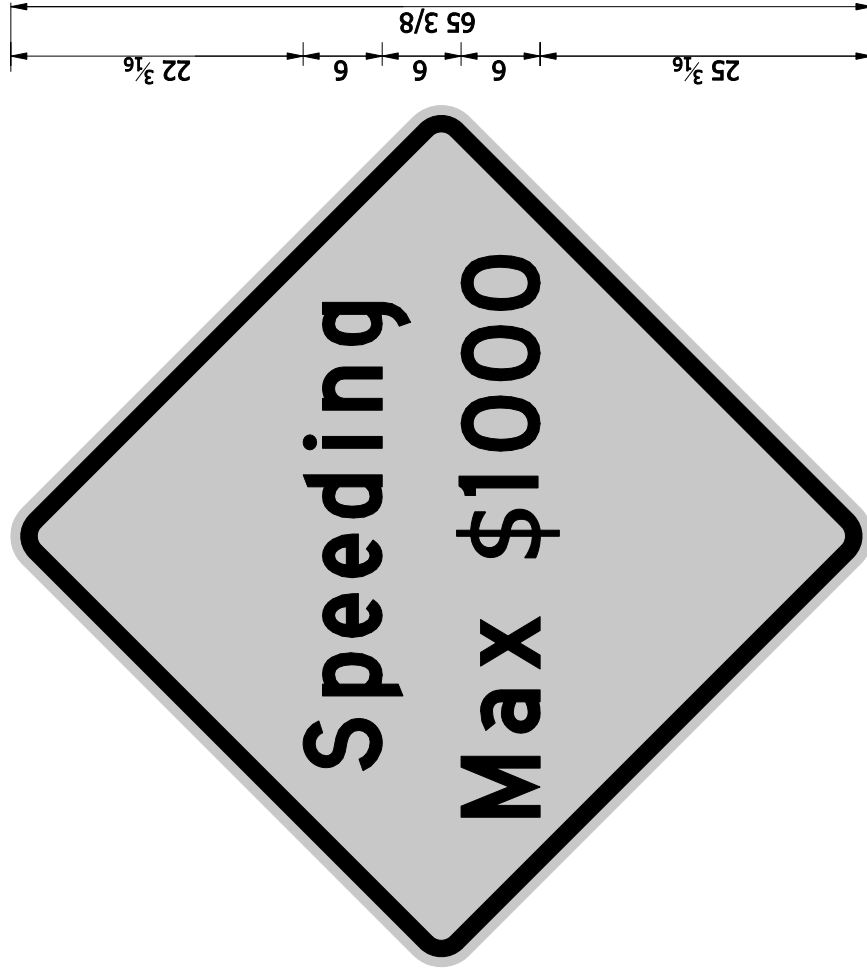

48x48 ; 6 D UPPER AND LOWER
48.000" across sides 3.000" Radius, 1.250" Border, 0.750" Indent, Black on Orange;
[Speeding] D; [Max \$1000] D;

XG20-7c

INDIANA DEPARTMENT OF TRANSPORTATION

WORKSITE ADDED
PENALTY SIGNS 48 x 48

NOTES:

- 1. The XW4-2 series signs depicted in the following Standard Drawings shall be superseded by the versions shown on this sheet and are further detailed in the Standard Highway Signs and Markings Book, 2004 edition.

- 801-TCCO-01
- 801-TCFO-03
- 801-TCLC-01
- 801-TCLC-02
- 801-TCLC-03
- 801-TCLC-04
- 801-TCLC-05
- 801-TCLC-06
- 801-TCLC-09
- 801-TCLC-10
- 801-TCLC-11
- 801-TCLC-13
- 801-TCLC-15
- 801-TCLC-16
- 801-TCSN-05
- 801-TCTC-06
- 801-TCTC-09
- 801-TCTC-10

The color and support post details provided on Standard Drawing E 801-TCSN-12 shall apply.

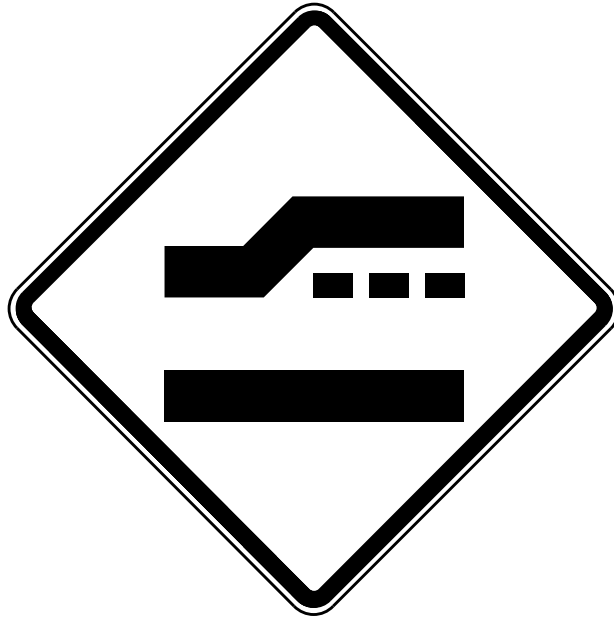

XW4-2(R)
XW4-2-A(R)

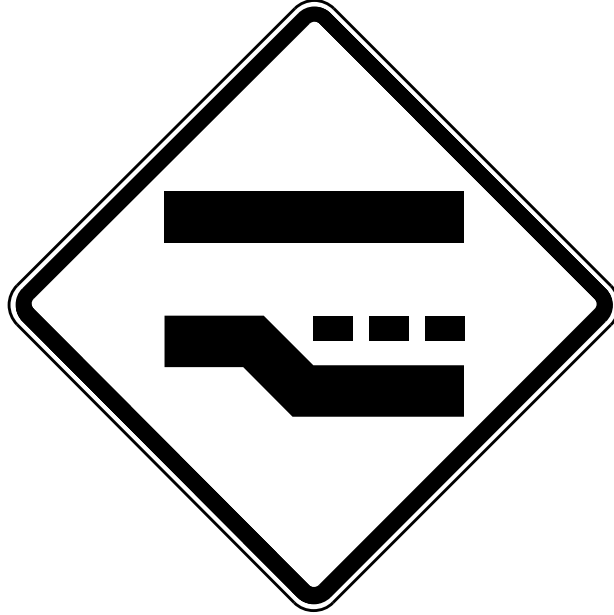

XW4-2(L)
XW4-2-A(L)

INDIANA DEPARTMENT OF TRANSPORTATION

LANE ENDS WARNING SIGNS

805-T-039d LOOP TESTING TABLE

(Adopted 09-01-05)

INTERSECTION _____ Contract No. _____

TEST PERFORMER-CONTRACTOR (C) _____ Date _____

TEST PERFORMER-STATE (S) _____ Date _____

		LOOP DESIGNATION												
NUMBER OF TURNS														
INDUCTANCE		READINGS AT DETECTOR HOUSING BEFORE SPLICED												
80 to 800 μ H														
RESISTANCE # 8 Ω														
VOLTAGE # 3 v														
MEGOHM (LOOP) > 100 M Ω														
MEGOHM (LEAD IN) >100 M Ω														
		READINGS AT CABINET AFTER SPLICED												
INDUCTANCE		C												
80 to 800 μ H		S												
RESISTANCE		C												
# 8 Ω		S												
VOLTAGE		C												
# 3 v		S												
MEGOHM		C												
WEST SPLICE >100 M Ω		S												
VEHICLE		C												
SIMULATOR		S												

DISTRIBUTION: Project File, District Traffic, Contractor

NOTES:

1. See Sheet 3 for rumble stripe placement at intersection, drive, bridge, or railroad crossing.
2. Rumble stripe shall be centered about the roadway centerline.
3. For asphalt pavements, the liquid asphalt sealant width shall be a minimum of 24 in., centered on the pavement center joint line, and shall be extended, when necessary, to provide coverage beyond the edge of the corrugation.
- ④ There shall be a maximum 5-ft gap with the corrugations being no closer than 6 in. to a concrete pavement transverse joint or a casting.

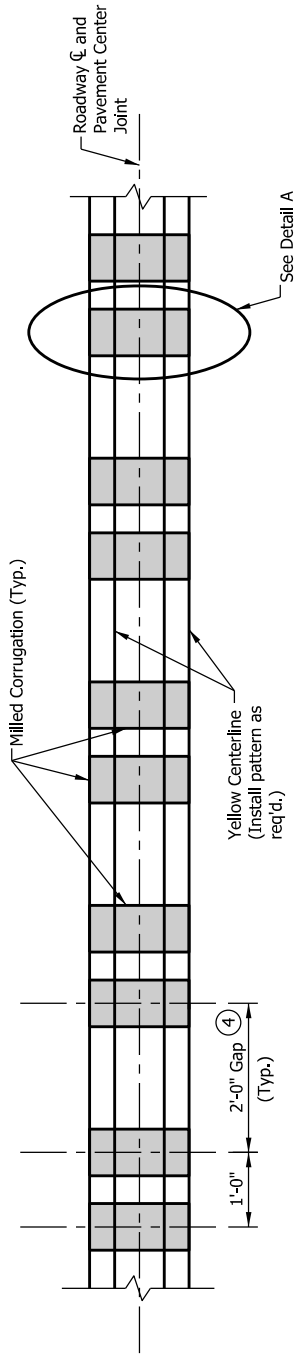

PLAN

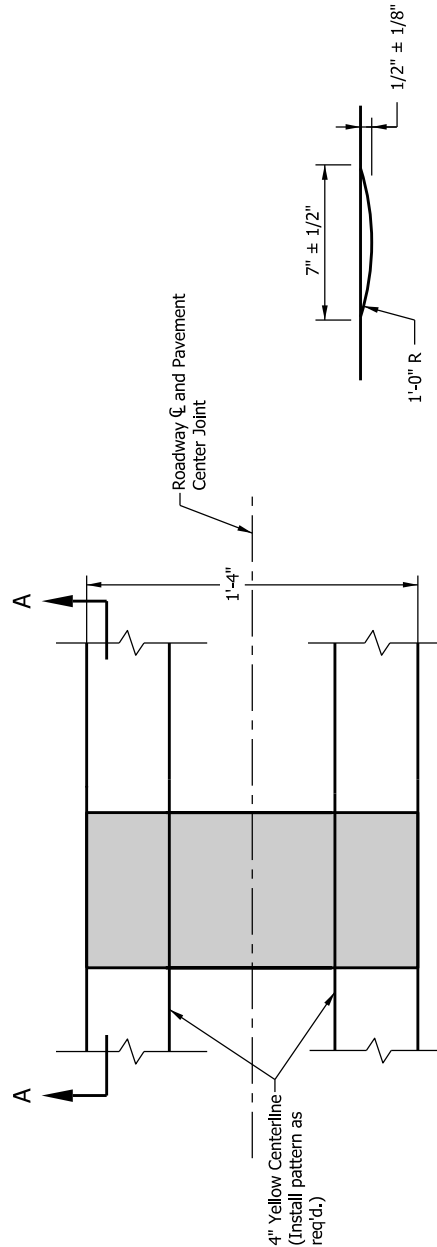

DETAIL A

INDIANA DEPARTMENT OF TRANSPORTATION
 CENTERLINE LONGITUDINAL
 RUMBLE STRIPE

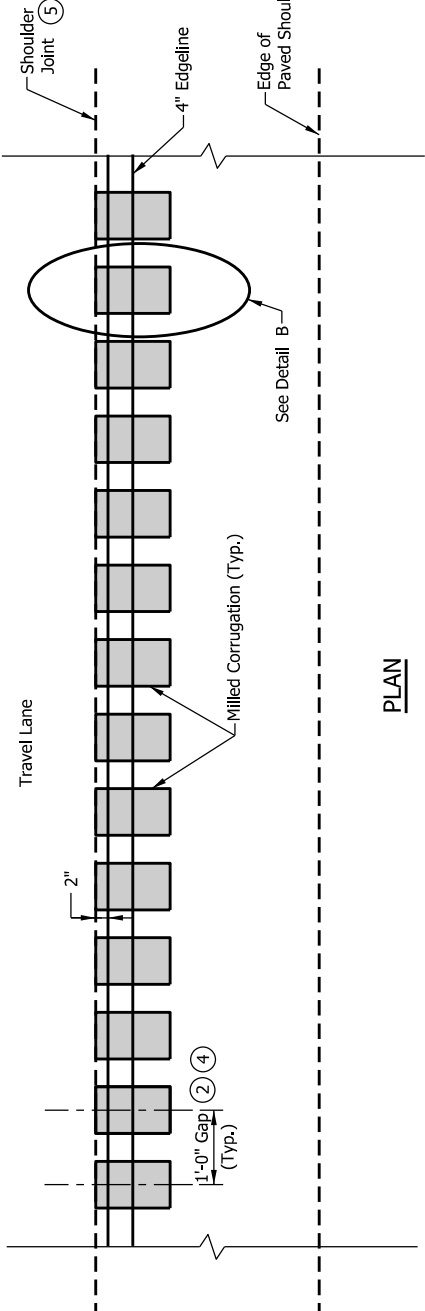

PLAN

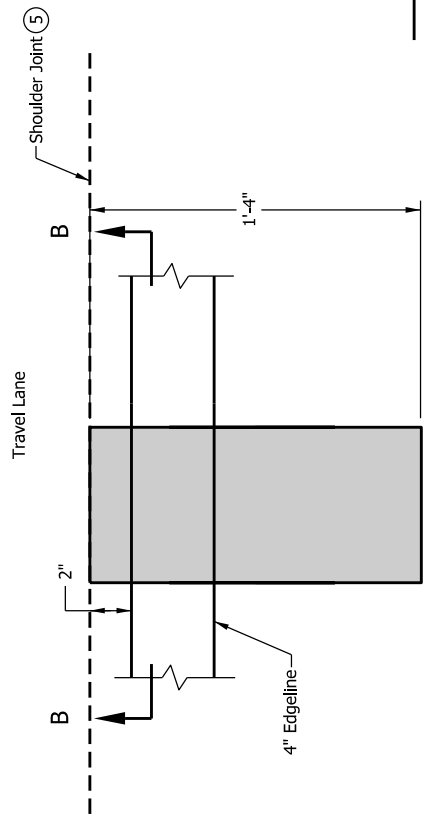

DETAIL B

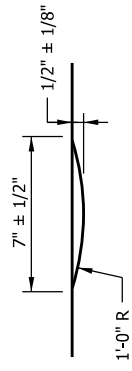

SECTION B-B

NOTES:

1. See Sheet 3 for rumble stripe placement at intersection, drive, bridge, or railroad crossing.
- ② When the paved shoulder width is at least 4 ft a 10-ft longitudinal gap in the milled corrugations shall be provided every 60 ft to accommodate bicycles.
3. For asphalt pavements, the liquid asphalt sealant width shall be a minimum of 24 in, centered on the shoulder joint line.
- ④ There shall be a maximum 5-ft gap with the corrugations being no closer than 6 in. to a concrete pavement transverse joint or a casting.
- ⑤ New edge of traveled pavement if shoulder joint is not apparent.

INDIANA DEPARTMENT OF TRANSPORTATION
 EDGELINE LONGITUDINAL
 RUMBLE STRIPE

NOTES:

1. See Sheet 1 for centerline corrugation pattern details.
2. See Sheet 2 for edgeline corrugation pattern details.
- ③ Rumble stripe shall begin or end at the stop bar location.
- ④ Rumble stripe shall be continued through driveway access points for minor driveways.
- ⑤ Gap is 15 ft for passive railroad crossing and 25 ft for railroad crossing with gates or signals.
6. For bridge deck, terminate corrugations a maximum of 5 ft and a minimum of 6 in. before an approach slab and resume corrugations a minimum of 6 in. and a maximum of 5 ft after the approach slab on the other side of the bridge deck.

KEY:

CLRS = Centerline Longitudinal Rumble Stripe
 ELRS = Edgeline Longitudinal Rumble Stripe

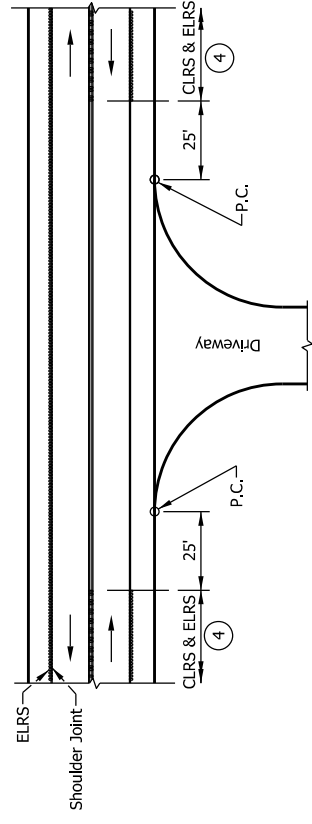
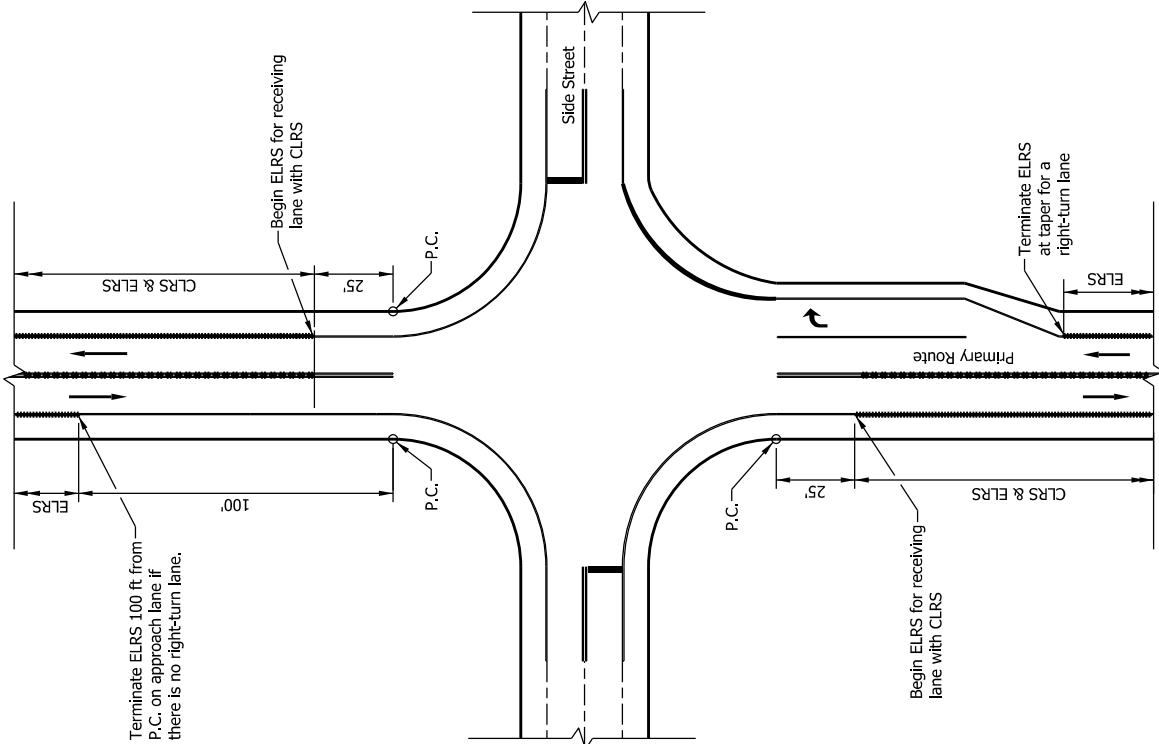

RUMBLE STRIPES AT MAJOR COMMERCIAL OR INDUSTRIAL DRIVEWAY

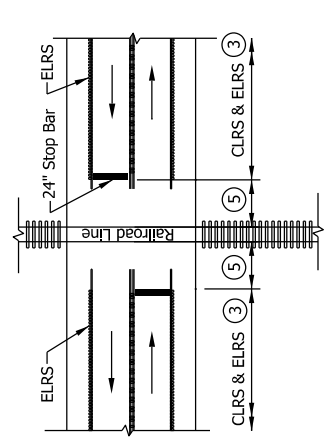

RUMBLE STRIPES AT RAILROAD CROSSING

INDIANA DEPARTMENT OF TRANSPORTATION
 LONGITUDINAL RUMBLE STRIPES
 AT INTERSECTION, DRIVE,
 OR RAILROAD CROSSING

RUMBLE STRIPES AT INTERSECTION

SPECIAL PROVISIONS
TABLE OF CONTENTS

100-C-147 PAYMENT OF PREDETERMINED MINIMUM WAGE DETERMINATION..... 1

100-C-151A FHWA-1273..... 1

100-C-151B DISADVANTAGED BUSINESS ENTERPRISE PROCEDURE AND GOOD FAITH EFFORTS
..... 13

100-C-151C DBE AND NON-DBE GOAL CONTRACTS RECORD KEEPING AND TIMELY PAY.... 21

100-C-151D EXECUTIVE ORDER 11246..... 21

100-C-151E TITLE VI ASSURANCES..... 31

100-C-188 STANDARD SPECIFICATIONS..... 33

100-C-209 SUBCONTRACT REPORT AND PAYMENTS REQUIREMENTS..... 33

100-C-214 CONSTRUCTION LETTING E-MAIL BOX..... 34

108-C-585 WORKING RESTRICTIONS DURING CERTAIN HOLIDAY PERIODS..... 34

109-C-219 PG ASPHALT BINDER MATERIAL COST ADJUSTMENTS..... 36

203-R-550 APPROVAL OF BORROW AND DISPOSAL SITES..... 38

306-R-613 MILLING..... 44

400-R-610 PROVISIONS FOR HMA MIXTURES..... 51

401-R-581 JOINT ADHESIVE..... 54

628-C-236 HANDS-FREE KITS FOR CELL PHONES..... 57

628-C-586 FIELD OFFICE COMPUTER EQUIPMENT..... 58

801-C-157 CERTIFICATION OF TEMPORARY TRAFFIC CONTROL DEVICES..... 60

801-C-237 TEMPORARY CONSTRUCTION SIGNS..... 61

801-M-006 MAINTAINING TRAFFIC FOR MAINTENANCE OR RESURFACE WORK..... 62

801-R-542 WORKSITE ADDED PENALTY SIGNS..... 62

801-T-194 AUTOMATED FLAGGER ASSISTANCE DEVICE..... 63

801-T-198 TRAFFIC CONTROL FOR TRAFFIC BREAKS..... 65

805-T-078 ELECTRICAL INSULATION SEALANT..... 66

808-T-190 LONGITUDINAL RUMBLE STRIPES..... 66

107-R-169 STATEMENTS ABOUT EXISTING CONDITIONS OF UTILITIES, ADDITIONAL
RIGHT-OF-WAY, AND ENCROACHMENTS..... 72

414-R-609 COST OF CLOSURE PERIODS FOR UBWC REMEDIAL WORK..... 73

HMA PATCHING, TYPE C..... 73

100-C-147 PAYMENT OF PREDETERMINED MINIMUM WAGE DETERMINATION
(DAVIS-BACON ACT)
General Decision Number IN140006

(Revised 01-14-14)

General Decision Number IN140006 shall apply to this contract.

The above referenced wage determination is available at the Department's Contract Administration Division website location: <http://www.in.gov/dot/div/contracts/letting/index.html>.

The modification number and publication date for the General Decision effective for the bid opening is posted on the Contract Administration website ten days prior to the bid opening. The bidder shall enter the appropriate modification number, General Decision Number, and publication date in the proposal form.

100-C-151A FHWA-1273

(Revised 05-01-12)

**REQUIRED CONTRACT PROVISIONS
FEDERAL-AID CONSTRUCTION CONTRACTS**

- I. General
- II. Nondiscrimination
- III. Nonsegregated Facilities
- IV. Davis-Bacon and Related Act Provisions
- V. Contract Work Hours and Safety Standards Act Provisions
- VI. Subletting or Assigning the Contract
- VII. Safety: Accident Prevention
- VIII. False Statements Concerning Highway Projects
- IX. Implementation of Clean Air Act and Federal Water Pollution Control Act
- X. Compliance with Governmentwide Suspension and Debarment Requirements
- XI. Certification Regarding Use of Contract Funds for Lobbying

ATTACHMENTS

A. Employment and Materials Preference for Appalachian Development Highway System or Appalachian Local Access Road Contracts (included in Appalachian contracts only)

I. GENERAL

1. Form FHWA-1273 must be physically incorporated in each construction contract funded under Title 23 (excluding emergency contracts solely intended for debris removal). The contractor (or subcontractor) must insert this form in each subcontract and further require its inclusion in all lower tier subcontracts (excluding purchase orders, rental agreements and other agreements for supplies or services).

The applicable requirements of Form FHWA-1273 are incorporated by reference for work done under any purchase order, rental agreement or agreement for other services. The prime contractor shall be responsible for compliance by any subcontractor, lower-tier subcontractor or service provider.

Form FHWA-1273 must be included in all Federal-aid design-build contracts, in all subcontracts and in lower tier subcontracts (excluding subcontracts for design services, purchase orders, rental agreements and other agreements for supplies or services). The design-builder shall be responsible for compliance by any subcontractor, lower-tier subcontractor or service provider.

Contracting agencies may reference Form FHWA-1273 in bid proposal or request for proposal documents, however, the Form FHWA-1273 must be physically incorporated (not referenced) in all contracts, subcontracts and lower-tier subcontracts (excluding purchase orders, rental agreements and other agreements for supplies or services related to a construction contract).

2. Subject to the applicability criteria noted in the following sections, these contract provisions shall apply to all work performed on

the contract by the contractor's own organization and with the assistance of workers under the contractor's immediate superintendence and to all work performed on the contract by piecework, station work, or by subcontract.

3. A breach of any of the stipulations contained in these Required Contract Provisions may be sufficient grounds for withholding of progress payments, withholding of final payment, termination of the contract, suspension / debarment or any other action determined to be appropriate by the contracting agency and FHWA.

4. Selection of Labor: During the performance of this contract, the contractor shall not use convict labor for any purpose within the limits of a construction project on a Federal-aid highway unless it is labor performed by convicts who are on parole, supervised release, or probation. The term Federal-aid highway does not include roadways functionally classified as local roads or rural minor collectors.

II. NONDISCRIMINATION

The provisions of this section related to 23 CFR Part 230 are applicable to all Federal-aid construction contracts and to all related construction subcontracts of \$10,000 or more. The provisions of 23 CFR Part 230 are not applicable to material supply, engineering, or architectural service contracts.

In addition, the contractor and all subcontractors must comply with the following policies: Executive Order 11246, 41 CFR 60, 29 CFR 1625-1627, Title 23 USC Section 140, the Rehabilitation Act of 1973, as amended (29 USC 794), Title VI of the Civil Rights Act of 1964, as amended, and related regulations including 49 CFR Parts 21, 26 and 27; and 23 CFR Parts 200, 230, and 633.

The contractor and all subcontractors must comply with: the requirements of the Equal Opportunity Clause in 41 CFR 601.4(b) and, for all construction contracts exceeding \$10,000, the Standard Federal Equal Employment Opportunity Construction Contract Specifications in 41 CFR 60-4.3.

Note: The U.S. Department of Labor has exclusive authority to determine compliance with Executive Order 11246 and the policies of the Secretary of Labor including 41 CFR 60, and 29 CFR 1625-1627. The contracting agency and the FHWA have the authority and the responsibility to ensure compliance with Title 23 USC Section 140, the Rehabilitation Act of 1973, as amended (29 USC 794), and Title VI of the Civil Rights Act of 1964, as amended, and related regulations including 49 CFR Parts 21, 26 and 27; and 23 CFR Parts 200, 230, and 633.

The following provision is adopted from 23 CFR 230, Appendix A, with appropriate revisions to conform to the U.S. Department of Labor (US DOL) and FHWA requirements.

1. Equal Employment Opportunity: Equal employment opportunity (EEO) requirements not to discriminate and to take affirmative action to assure equal opportunity as set forth under laws, executive orders, rules, regulations (28 CFR 35, 29 CFR 1630, 29 CFR 1625-1627, 41 CFR 60 and 49 CFR 27) and orders of the Secretary of Labor as modified by the provisions prescribed herein, and imposed pursuant to 23 U.S.C. 140 shall constitute the EEO and specific affirmative action standards for the contractor's project activities under this contract. The provisions of the Americans with Disabilities Act of 1990 (42 U.S.C. 12101 et seq.) set forth under 28 CFR 35 and 29 CFR 1630 are incorporated by reference in this contract. In the execution of this contract, the contractor agrees to comply with the following minimum specific requirement activities of EEO:

a. The contractor will work with the contracting agency and the Federal Government to ensure that it has made every good faith effort to provide equal opportunity with respect to all of its terms and conditions of employment and in their review of activities under the contract.

b. The contractor will accept as its operating policy the following statement:

"It is the policy of this Company to assure that applicants are employed, and that employees are treated during employment, without regard to their race, religion, sex, color, national origin, age or disability. Such action shall include: employment, upgrading, demotion, or transfer; recruitment or recruitment advertising; layoff or termination; rates of pay or other forms of compensation; and selection for training, including apprenticeship, pre-apprenticeship, and/or on-the-job training."

2. EEO Officer: The contractor will designate and make known to the contracting officers an EEO Officer who will have the responsibility for and must be capable of effectively administering and promoting an active EEO program and who must be assigned adequate authority and responsibility to do so.

3. Dissemination of Policy: All members of the contractor's staff who are authorized to hire, supervise, promote, and discharge employees, or who recommend such action, or who are substantially involved in such action, will be made fully cognizant of, and will implement, the contractor's EEO policy and contractual responsibilities to provide EEO in each grade and classification of employment. To ensure that the above agreement will be met, the following actions will be taken as a minimum:

a. Periodic meetings of supervisory and personnel office employees will be conducted before the start of work and then not less often than once every six months, at which time the contractor's EEO policy and its implementation will be reviewed and explained. The meetings will be conducted by the EEO Officer.

b. All new supervisory or personnel office employees will be given a thorough indoctrination by the EEO Officer, covering all major aspects of the contractor's EEO obligations within thirty days following their reporting for duty with the contractor.

c. All personnel who are engaged in direct recruitment for the project will be instructed by the EEO Officer in the contractor's procedures for locating and hiring minorities and women.

d. Notices and posters setting forth the contractor's EEO policy will be placed in areas readily accessible to employees, applicants for employment and potential employees.

e. The contractor's EEO policy and the procedures to implement such policy will be brought to the attention of employees by means of meetings, employee handbooks, or other appropriate means.

4. Recruitment: When advertising for employees, the contractor will include in all advertisements for employees the notation: "An Equal Opportunity Employer." All such advertisements will be placed in publications having a large circulation among minorities and women in the area from which the project work force would normally be derived.

a. The contractor will, unless precluded by a valid bargaining agreement, conduct systematic and direct recruitment through public and private employee referral sources likely to yield qualified minorities and women. To meet this requirement, the contractor will identify sources of potential minority group employees, and establish with such identified sources procedures whereby minority and women applicants may be referred to the contractor for employment consideration.

b. In the event the contractor has a valid bargaining agreement providing for exclusive hiring hall referrals, the contractor is expected to observe the provisions of that agreement to the extent that the system meets the contractor's compliance with EEO contract provisions. Where implementation of such an agreement has the effect of discriminating against minorities or women, or obligates the contractor to do the same, such implementation violates Federal nondiscrimination provisions.

c. The contractor will encourage its present employees to refer minorities and women as applicants for employment. Information and procedures with regard to referring such applicants will be discussed with employees.

5. Personnel Actions: Wages, working conditions, and employee benefits shall be established and administered, and personnel actions of every type, including hiring, upgrading, promotion, transfer, demotion, layoff, and termination, shall be taken without regard to race, color, religion, sex, national origin, age or disability. The following procedures shall be followed:

a. The contractor will conduct periodic inspections of project sites to insure that working conditions and employee facilities do not indicate discriminatory treatment of project site personnel.

b. The contractor will periodically evaluate the spread of wages paid within each classification to determine any evidence of discriminatory wage practices.

c. The contractor will periodically review selected personnel actions in depth to determine whether there is evidence of discrimination. Where evidence is found, the contractor will promptly take corrective action. If the review indicates that the discrimination may extend beyond the actions reviewed, such corrective action shall include all affected persons.

d. The contractor will promptly investigate all complaints of alleged discrimination made to the contractor in connection with its obligations under this contract, will attempt to resolve such complaints, and will take appropriate corrective action within a reasonable time. If the investigation indicates that the discrimination may affect persons other than the complainant, such corrective action shall include such other persons. Upon completion of each investigation, the contractor will inform every complainant of all of their avenues of appeal.

6. Training and Promotion:

a. The contractor will assist in locating, qualifying, and increasing the skills of minorities and women who are applicants for employment or current employees. Such efforts should be aimed at developing full journey level status employees in the type of trade or job classification involved.

b. Consistent with the contractor's work force requirements and as permissible under Federal and State regulations, the contractor shall make full use of training programs, i.e., apprenticeship, and on-the-job training programs for the geographical area of contract performance. In the event a special provision for training is provided under this contract, this subparagraph will be superseded as indicated in the special provision. The contracting agency may reserve training positions for persons who receive welfare assistance in accordance with 23 U.S.C. 140(a).

c. The contractor will advise employees and applicants for employment of available training programs and entrance requirements for each.

d. The contractor will periodically review the training and promotion potential of employees who are minorities and women and will encourage eligible employees to apply for such training and promotion.

7. Unions: If the contractor relies in whole or in part upon unions as a source of employees, the contractor will use good faith efforts to obtain the cooperation of such unions to increase opportunities for minorities and women. Actions by the contractor, either directly or through a contractor's association acting as agent, will include the procedures set forth below:

a. The contractor will use good faith efforts to develop, in cooperation with the unions, joint training programs aimed toward qualifying more minorities and women for membership in the unions and increasing the skills of minorities and women so that they

may qualify for higher paying employment.

b. The contractor will use good faith efforts to incorporate an EEO clause into each union agreement to the end that such union will be contractually bound to refer applicants without regard to their race, color, religion, sex, national origin, age or disability.

c. The contractor is to obtain information as to the referral practices and policies of the labor union except that to the extent such information is within the exclusive possession of the labor union and such labor union refuses to furnish such information to the contractor, the contractor shall so certify to the contracting agency and shall set forth what efforts have been made to obtain such information.

d. In the event the union is unable to provide the contractor with a reasonable flow of referrals within the time limit set forth in the collective bargaining agreement, the contractor will, through independent recruitment efforts, fill the employment vacancies without regard to race, color, religion, sex, national origin, age or disability; making full efforts to obtain qualified and/or qualifiable minorities and women. The failure of a union to provide sufficient referrals (even though it is obligated to provide exclusive referrals under the terms of a collective bargaining agreement) does not relieve the contractor from the requirements of this paragraph. In the event the union referral practice prevents the contractor from meeting the obligations pursuant to Executive Order 11246, as amended, and these special provisions, such contractor shall immediately notify the contracting agency.

8. Reasonable Accommodation for Applicants / Employees with Disabilities: The contractor must be familiar with the requirements for and comply with the Americans with Disabilities Act and all rules and regulations established there under. Employers must provide reasonable accommodation in all employment activities unless to do so would cause an undue hardship.

9. Selection of Subcontractors, Procurement of Materials and Leasing of Equipment: The contractor shall not discriminate on the grounds of race, color, religion, sex, national origin, age or disability in the selection and retention of subcontractors, including procurement of materials and leases of equipment. The contractor shall take all necessary and reasonable steps to ensure nondiscrimination in the administration of this contract.

a. The contractor shall notify all potential subcontractors and suppliers and lessors of their EEO obligations under this contract.

b. The contractor will use good faith efforts to ensure subcontractor compliance with their EEO obligations.

10. Assurance Required by 49 CFR 26.13(b):

a. The requirements of 49 CFR Part 26 and the State DOT's U.S. DOT-approved DBE program are incorporated by reference.

b. The contractor or subcontractor shall not discriminate on the basis of race, color, national origin, or sex in the performance of this contract. The contractor shall carry out applicable requirements of 49 CFR Part 26 in the award and administration of DOT-assisted contracts. Failure by the contractor to carry out these requirements is a material breach of this contract, which may result in the termination of this contract or such other remedy as the contracting agency deems appropriate.

11. Records and Reports: The contractor shall keep such records as necessary to document compliance with the EEO requirements. Such records shall be retained for a period of three years following the date of the final payment to the contractor for all contract work and shall be available at reasonable times and places for inspection by authorized representatives of the contracting agency and the FHWA.

a. The records kept by the contractor shall document the following:

(1) The number and work hours of minority and non-minority group members and women employed in each work classification on the project;

(2) The progress and efforts being made in cooperation with unions, when applicable, to increase employment opportunities for minorities and women; and

(3) The progress and efforts being made in locating, hiring, training, qualifying, and upgrading minorities and women;

b. The contractors and subcontractors will submit an annual report to the contracting agency each July for the duration of the project, indicating the number of minority, women, and non-minority group employees currently engaged in each work classification required by the contract work. This information is to be reported on [Form FHWA-1391](#). The staffing data should represent the project work force on board in all or any part of the last payroll period preceding the end of July. If on-the-job training is being required by special provision, the contractor will be required to collect and report training data. The employment data should reflect the work force on board during all or any part of the last payroll period preceding the end of July.

III. NONSEGREGATED FACILITIES

This provision is applicable to all Federal-aid construction contracts and to all related construction subcontracts of \$10,000 or more.

The contractor must ensure that facilities provided for employees are provided in such a manner that segregation on the basis of race, color, religion, sex, or national origin cannot result. The contractor may neither require such segregated use by written or oral policies nor tolerate such use by employee custom. The contractor's obligation extends further to ensure that its employees are not assigned to perform their services at any location, under the contractor's control, where the facilities are segregated. The term

"facilities" includes waiting rooms, work areas, restaurants and other eating areas, time clocks, restrooms, washrooms, locker rooms, and other storage or dressing areas, parking lots, drinking fountains, recreation or entertainment areas, transportation, and housing provided for employees. The contractor shall provide separate or single-user restrooms and necessary dressing or sleeping areas to assure privacy between sexes.

IV. DAVIS-BACON AND RELATED ACT PROVISIONS

This section is applicable to all Federal-aid construction projects exceeding \$2,000 and to all related subcontracts and lower-tier subcontracts (regardless of subcontract size). The requirements apply to all projects located within the right-of-way of a roadway that is functionally classified as Federal-aid highway. This excludes roadways functionally classified as local roads or rural minor collectors, which are exempt. Contracting agencies may elect to apply these requirements to other projects.

The following provisions are from the U.S. Department of Labor regulations in 29 CFR 5.5 "Contract provisions and related matters" with minor revisions to conform to the FHWA1273 format and FHWA program requirements.

1. Minimum wages

a. All laborers and mechanics employed or working upon the site of the work, will be paid unconditionally and not less often than once a week, and without subsequent deduction or rebate on any account (except such payroll deductions as are permitted by regulations issued by the Secretary of Labor under the Copeland Act (29 CFR part 3)), the full amount of wages and bona fide fringe benefits (or cash equivalents thereof) due at time of payment computed at rates not less than those contained in the wage determination of the Secretary of Labor which is attached hereto and made a part hereof, regardless of any contractual relationship which may be alleged to exist between the contractor and such laborers and mechanics.

Contributions made or costs reasonably anticipated for bona fide fringe benefits under section 1(b)(2) of the Davis-Bacon Act on behalf of laborers or mechanics are considered wages paid to such laborers or mechanics, subject to the provisions of paragraph 1.d. of this section; also, regular contributions made or costs incurred for more than a weekly period (but not less often than quarterly) under plans, funds, or programs which cover the particular weekly period, are deemed to be constructively made or incurred during such weekly period. Such laborers and mechanics shall be paid the appropriate wage rate and fringe benefits on the wage determination for the classification of work actually performed, without regard to skill, except as provided in 29 CFR 5.5(a)(4). Laborers or mechanics performing work in more than one classification may be compensated at the rate specified for each classification for the time actually worked therein: Provided, That the employer's payroll records accurately set forth the time spent in each classification in which work is performed. The wage determination (including any additional classification and wage rates conformed under paragraph 1.b. of this section) and the Davis-Bacon poster (WH-1321) shall be posted at all times by the contractor and its subcontractors at the site of the work in a prominent and accessible place where it can be easily seen by the workers.

b. (1) The contracting officer shall require that any class of laborers or mechanics, including helpers, which is not listed in the wage determination and which is to be employed under the contract shall be classified in conformance with the wage determination. The contracting officer shall approve an additional classification and wage rate and fringe benefits therefore only when the following criteria have been met:

(i) The work to be performed by the classification requested is not performed by a classification in the wage determination; and

(ii) The classification is utilized in the area by the construction industry; and

(iii) The proposed wage rate, including any bona fide fringe benefits, bears a reasonable relationship to the wage rates contained in the wage determination.

(2) If the contractor and the laborers and mechanics to be employed in the classification (if known), or their representatives, and the contracting officer agree on the classification and wage rate (including the amount designated for fringe benefits where appropriate), a report of the action taken shall be sent by the contracting officer to the Administrator of the Wage and Hour Division, Employment Standards Administration, U.S. Department of Labor, Washington, DC 20210. The Administrator, or an authorized representative, will approve, modify, or disapprove every additional classification action within 30 days of receipt and so advise the contracting officer or will notify the contracting officer within the 30-day period that additional time is necessary.

(3) In the event the contractor, the laborers or mechanics to be employed in the classification or their representatives, and the contracting officer do not agree on the proposed classification and wage rate (including the amount designated for fringe benefits, where appropriate), the contracting officer shall refer the questions, including the views of all interested parties and the recommendation of the contracting officer, to the Wage and Hour Administrator for determination. The Wage and Hour Administrator, or an authorized representative, will issue a determination within 30 days of receipt and so advise the contracting officer or will notify the contracting officer within the 30-day period that additional time is necessary.

(4) The wage rate (including fringe benefits where appropriate) determined pursuant to paragraphs 1.b.(2) or 1.b.(3) of this section, shall be paid to all workers performing work in the classification under this contract from the first day on which work is performed in the classification.

c. Whenever the minimum wage rate prescribed in the contract for a class of laborers or mechanics includes a fringe benefit which is not expressed as an hourly rate, the contractor shall either pay the benefit as stated in the wage determination or shall pay

another bona fide fringe benefit or an hourly cash equivalent thereof.

d. If the contractor does not make payments to a trustee or other third person, the contractor may consider as part of the wages of any laborer or mechanic the amount of any costs reasonably anticipated in providing bona fide fringe benefits under a plan or program, Provided, That the Secretary of Labor has found, upon the written request of the contractor, that the applicable standards of the Davis-Bacon Act have been met. The Secretary of Labor may require the contractor to set aside in a separate account assets for the meeting of obligations under the plan or program.

2. Withholding

The contracting agency shall upon its own action or upon written request of an authorized representative of the Department of Labor, withhold or cause to be withheld from the contractor under this contract, or any other Federal contract with the same prime contractor, or any other federally-assisted contract subject to Davis-Bacon prevailing wage requirements, which is held by the same prime contractor, so much of the accrued payments or advances as may be considered necessary to pay laborers and mechanics, including apprentices, trainees, and helpers, employed by the contractor or any subcontractor the full amount of wages required by the contract. In the event of failure to pay any laborer or mechanic, including any apprentice, trainee, or helper, employed or working on the site of the work, all or part of the wages required by the contract, the contracting agency may, after written notice to the contractor, take such action as may be necessary to cause the suspension of any further payment, advance, or guarantee of funds until such violations have ceased.

3. Payrolls and basic records

a. Payrolls and basic records relating thereto shall be maintained by the contractor during the course of the work and preserved for a period of three years thereafter for all laborers and mechanics working at the site of the work. Such records shall contain the name, address, and social security number of each such worker, his or her correct classification, hourly rates of wages paid (including rates of contributions or costs anticipated for bona fide fringe benefits or cash equivalents thereof of the types described in section 1(b)(2)(B) of the Davis-Bacon Act), daily and weekly number of hours worked, deductions made and actual wages paid. Whenever the Secretary of Labor has found under 29 CFR 5.5(a)(1)(iv) that the wages of any laborer or mechanic include the amount of any costs reasonably anticipated in providing benefits under a plan or program described in section 1(b)(2)(B) of the Davis-Bacon Act, the contractor shall maintain records which show that the commitment to provide such benefits is enforceable, that the plan or program is financially responsible, and that the plan or program has been communicated in writing to the laborers or mechanics affected, and records which show the costs anticipated or the actual cost incurred in providing such benefits. Contractors employing apprentices or trainees under approved programs shall maintain written evidence of the registration of apprenticeship programs and certification of trainee programs, the registration of the apprentices and trainees, and the ratios and wage rates prescribed in the applicable programs.

b. (1) The contractor shall submit weekly for each week in which any contract work is performed a copy of all payrolls to the contracting agency. The payrolls submitted shall set out accurately and completely all of the information required to be maintained under 29 CFR 5.5(a)(3)(i), except that full social security numbers and home addresses shall not be included on weekly transmittals. Instead the payrolls shall only need to include an individually identifying number for each employee (e.g., the last four digits of the employee's social security number). The required weekly payroll information may be submitted in any form desired. Optional Form WH-347 is available for this purpose from the Wage and Hour Division Web site at <http://www.dol.gov/esa/whd/forms/wh347instr.htm> or its successor site. The prime contractor is responsible for the submission of copies of payrolls by all subcontractors. Contractors and subcontractors shall maintain the full social security number and current address of each covered worker, and shall provide them upon request to the contracting agency for transmission to the State DOT, the FHWA or the Wage and Hour Division of the Department of Labor for purposes of an investigation or audit of compliance with prevailing wage requirements. It is not a violation of this section for a prime contractor to require a subcontractor to provide addresses and social security numbers to the prime contractor for its own records, without weekly submission to the contracting agency.

(2) Each payroll submitted shall be accompanied by a "Statement of Compliance," signed by the contractor or subcontractor or his or her agent who pays or supervises the payment of the persons employed under the contract and shall certify the following:

(i) That the payroll for the payroll period contains the information required to be provided under §5.5 (a)(3)(ii) of Regulations, 29 CFR part 5, the appropriate information is being maintained under §5.5 (a)(3)(i) of Regulations, 29 CFR part 5, and that such information is correct and complete;

(ii) That each laborer or mechanic (including each helper, apprentice, and trainee) employed on the contract during the payroll period has been paid the full weekly wages earned, without rebate, either directly or indirectly, and that no deductions have been made either directly or indirectly from the full wages earned, other than permissible deductions as set forth in Regulations, 29 CFR part 3;

(iii) That each laborer or mechanic has been paid not less than the applicable wage rates and fringe benefits or cash equivalents for the classification of work performed, as specified in the applicable wage determination incorporated into the contract.

(3) The weekly submission of a properly executed certification set forth on the reverse side of Optional Form WH-347 shall satisfy the requirement for submission of the "Statement of Compliance" required by paragraph 3.b.(2) of this section.

(4) The falsification of any of the above certifications may subject the contractor or subcontractor to civil or criminal

prosecution under section 1001 of title 18 and section 231 of title 31 of the United States Code.

c. The contractor or subcontractor shall make the records required under paragraph 3.a. of this section available for inspection, copying, or transcription by authorized representatives of the contracting agency, the State DOT, the FHWA, or the Department of Labor, and shall permit such representatives to interview employees during working hours on the job. If the contractor or subcontractor fails to submit the required records or to make them available, the FHWA may, after written notice to the contractor, the contracting agency or the State DOT, take such action as may be necessary to cause the suspension of any further payment, advance, or guarantee of funds. Furthermore, failure to submit the required records upon request or to make such records available may be grounds for debarment action pursuant to 29 CFR 5.12.

4. Apprentices and trainees

a. Apprentices (programs of the USDOL).

Apprentices will be permitted to work at less than the predetermined rate for the work they performed when they are employed pursuant to and individually registered in a bona fide apprenticeship program registered with the U.S. Department of Labor, Employment and Training Administration, Office of Apprenticeship Training, Employer and Labor Services, or with a State Apprenticeship Agency recognized by the Office, or if a person is employed in his or her first 90 days of probationary employment as an apprentice in such an apprenticeship program, who is not individually registered in the program, but who has been certified by the Office of Apprenticeship Training, Employer and Labor Services or a State Apprenticeship Agency (where appropriate) to be eligible for probationary employment as an apprentice.

The allowable ratio of apprentices to journeymen on the job site in any craft classification shall not be greater than the ratio permitted to the contractor as to the entire work force under the registered program. Any worker listed on a payroll at an apprentice wage rate, who is not registered or otherwise employed as stated above, shall be paid not less than the applicable wage rate on the wage determination for the classification of work actually performed. In addition, any apprentice performing work on the job site in excess of the ratio permitted under the registered program shall be paid not less than the applicable wage rate on the wage determination for the work actually performed. Where a contractor is performing construction on a project in a locality other than that in which its program is registered, the ratios and wage rates (expressed in percentages of the journeyman's hourly rate) specified in the contractor's or subcontractor's registered program shall be observed.

Every apprentice must be paid at not less than the rate specified in the registered program for the apprentice's level of progress, expressed as a percentage of the journeymen hourly rate specified in the applicable wage determination. Apprentices shall be paid fringe benefits in accordance with the provisions of the apprenticeship program. If the apprenticeship program does not specify fringe benefits, apprentices must be paid the full amount of fringe benefits listed on the wage determination for the applicable classification. If the Administrator determines that a different practice prevails for the applicable apprentice classification, fringes shall be paid in accordance with that determination.

In the event the Office of Apprenticeship Training, Employer and Labor Services, or a State Apprenticeship Agency recognized by the Office, withdraws approval of an apprenticeship program, the contractor will no longer be permitted to utilize apprentices at less than the applicable predetermined rate for the work performed until an acceptable program is approved.

b. Trainees (programs of the USDOL).

Except as provided in 29 CFR 5.16, trainees will not be permitted to work at less than the predetermined rate for the work performed unless they are employed pursuant to and individually registered in a program which has received prior approval, evidenced by formal certification by the U.S. Department of Labor, Employment and Training Administration.

The ratio of trainees to journeymen on the job site shall not be greater than permitted under the plan approved by the Employment and Training Administration.

Every trainee must be paid at not less than the rate specified in the approved program for the trainee's level of progress, expressed as a percentage of the journeyman hourly rate specified in the applicable wage determination. Trainees shall be paid fringe benefits in accordance with the provisions of the trainee program. If the trainee program does not mention fringe benefits, trainees shall be paid the full amount of fringe benefits listed on the wage determination unless the Administrator of the Wage and Hour Division determines that there is an apprenticeship program associated with the corresponding journeyman wage rate on the wage determination which provides for less than full fringe benefits for apprentices. Any employee listed on the payroll at a trainee rate who is not registered and participating in a training plan approved by the Employment and Training Administration shall be paid not less than the applicable wage rate on the wage determination for the classification of work actually performed. In addition, any trainee performing work on the job site in excess of the ratio permitted under the registered program shall be paid not less than the applicable wage rate on the wage determination for the work actually performed.

In the event the Employment and Training Administration withdraws approval of a training program, the contractor will no longer be permitted to utilize trainees at less than the applicable predetermined rate for the work performed until an acceptable program is approved.

c. Equal employment opportunity. The utilization of apprentices, trainees and journeymen under this part shall be in conformity with the equal employment opportunity requirements of Executive Order 11246, as amended, and 29 CFR part 30.

d. Apprentices and Trainees (programs of the U.S. DOT).

Apprentices and trainees working under apprenticeship and skill training programs which have been certified by the Secretary of Transportation as promoting EEO in connection with Federal-aid highway construction programs are not subject to the requirements of paragraph 4 of this Section IV. The straight time hourly wage rates for apprentices and trainees under such programs will be established by the particular programs. The ratio of apprentices and trainees to journeymen shall not be greater than permitted by the terms of the particular program.

5. Compliance with Copeland Act requirements. The contractor shall comply with the requirements of 29 CFR part 3, which are incorporated by reference in this contract.

6. Subcontracts. The contractor or subcontractor shall insert Form FHWA-1273 in any subcontracts and also require the subcontractors to include Form FHWA-1273 in any lower tier subcontracts. The prime contractor shall be responsible for the compliance by any subcontractor or lower tier subcontractor with all the contract clauses in 29 CFR 5.5.

7. Contract termination: debarment. A breach of the contract clauses in 29 CFR 5.5 may be grounds for termination of the contract, and for debarment as a contractor and a subcontractor as provided in 29 CFR 5.12.

8. Compliance with Davis-Bacon and Related Act requirements. All rulings and interpretations of the Davis-Bacon and Related Acts contained in 29 CFR parts 1, 3, and 5 are herein incorporated by reference in this contract.

9. Disputes concerning labor standards. Disputes arising out of the labor standards provisions of this contract shall not be subject to the general disputes clause of this contract. Such disputes shall be resolved in accordance with the procedures of the Department of Labor set forth in 29 CFR parts 5, 6, and 7. Disputes within the meaning of this clause include disputes between the contractor (or any of its subcontractors) and the contracting agency, the U.S. Department of Labor, or the employees or their representatives.

10. Certification of eligibility.

a. By entering into this contract, the contractor certifies that neither it (nor he or she) nor any person or firm who has an interest in the contractor's firm is a person or firm ineligible to be awarded Government contracts by virtue of section 3(a) of the Davis-Bacon Act or 29 CFR 5.12(a)(1).

b. No part of this contract shall be subcontracted to any person or firm ineligible for award of a Government contract by virtue of section 3(a) of the Davis-Bacon Act or 29 CFR 5.12(a)(1).

c. The penalty for making false statements is prescribed in the U.S. Criminal Code, 18 U.S.C. 1001.

V. CONTRACT WORK HOURS AND SAFETY STANDARDS ACT

The following clauses apply to any Federal-aid construction contract in an amount in excess of \$100,000 and subject to the overtime provisions of the Contract Work Hours and Safety Standards Act. These clauses shall be inserted in addition to the clauses required by 29 CFR 5.5(a) or 29 CFR 4.6. As used in this paragraph, the terms laborers and mechanics include watchmen and guards.

1. Overtime requirements. No contractor or subcontractor contracting for any part of the contract work which may require or involve the employment of laborers or mechanics shall require or permit any such laborer or mechanic in any workweek in which he or she is employed on such work to work in excess of forty hours in such workweek unless such laborer or mechanic receives compensation at a rate not less than one and one-half times the basic rate of pay for all hours worked in excess of forty hours in such workweek.

2. Violation; liability for unpaid wages; liquidated damages. In the event of any violation of the clause set forth in paragraph (1.) of this section, the contractor and any subcontractor responsible therefor shall be liable for the unpaid wages. In addition, such contractor and subcontractor shall be liable to the United States (in the case of work done under contract for the District of Columbia or a territory, to such District or to such territory), for liquidated damages. Such liquidated damages shall be computed with respect to each individual laborer or mechanic, including watchmen and guards, employed in violation of the clause set forth in paragraph (1.) of this section, in the sum of \$10 for each calendar day on which such individual was required or permitted to work in excess of the standard workweek of forty hours without payment of the overtime wages required by the clause set forth in paragraph (1.) of this section.

3. Withholding for unpaid wages and liquidated damages.

The FHWA or the contacting agency shall upon its own action or upon written request of an authorized representative of the Department of Labor withhold or cause to be withheld, from any moneys payable on account of work performed by the contractor or subcontractor under any such contract or any other Federal contract with the same prime contractor, or any other federally-assisted contract subject to the Contract Work Hours and Safety Standards Act, which is held by the same prime contractor, such sums as may be determined to be necessary to satisfy any liabilities of such contractor or subcontractor for unpaid wages and liquidated damages as provided in the clause set forth in paragraph (2.) of this section.

4. Subcontracts. The contractor or subcontractor shall insert in any subcontracts the clauses set forth in paragraph (1.) through (4.) of this section and also a clause requiring the subcontractors to include these clauses in any lower tier subcontracts. The prime contractor shall be responsible for compliance by any subcontractor or lower tier subcontractor with the clauses set forth in paragraphs (1.) through (4.) of this section.

VI. SUBLETTING OR ASSIGNING THE CONTRACT

This provision is applicable to all Federal-aid construction contracts on the National Highway System.

1. The contractor shall perform with its own organization contract work amounting to not less than 30 percent (or a greater percentage if specified elsewhere in the contract) of the total original contract price, excluding any specialty items designated by the contracting agency. Specialty items may be performed by subcontract and the amount of any such specialty items performed may be deducted from the total original contract price before computing the amount of work required to be performed by the contractor's own organization (23 CFR 635.116).

a. The term "perform work with its own organization" refers to workers employed or leased by the prime contractor, and equipment owned or rented by the prime contractor, with or without operators. Such term does not include employees or equipment of a subcontractor or lower tier subcontractor, agents of the prime contractor, or any other assignees. The term may include payments for the costs of hiring leased employees from an employee leasing firm meeting all relevant Federal and State regulatory requirements. Leased employees may only be included in this term if the prime contractor meets all of the following conditions:

- (1) the prime contractor maintains control over the supervision of the day-to-day activities of the leased employees;
- (2) the prime contractor remains responsible for the quality of the work of the leased employees;
- (3) the prime contractor retains all power to accept or exclude individual employees from work on the project; and
- (4) the prime contractor remains ultimately responsible for the payment of predetermined minimum wages, the submission of payrolls, statements of compliance and all other Federal regulatory requirements.

b. "Specialty Items" shall be construed to be limited to work that requires highly specialized knowledge, abilities, or equipment not ordinarily available in the type of contracting organizations qualified and expected to bid or propose on the contract as a whole and in general are to be limited to minor components of the overall contract.

2. The contract amount upon which the requirements set forth in paragraph (1) of Section VI is computed includes the cost of material and manufactured products which are to be purchased or produced by the contractor under the contract provisions.

3. The contractor shall furnish (a) a competent superintendent or supervisor who is employed by the firm, has full authority to direct performance of the work in accordance with the contract requirements, and is in charge of all construction operations (regardless of who performs the work) and (b) such other of its own organizational resources (supervision, management, and engineering services) as the contracting officer determines is necessary to assure the performance of the contract.

4. No portion of the contract shall be sublet, assigned or otherwise disposed of except with the written consent of the contracting officer, or authorized representative, and such consent when given shall not be construed to relieve the contractor of any responsibility for the fulfillment of the contract. Written consent will be given only after the contracting agency has assured that each subcontract is evidenced in writing and that it contains all pertinent provisions and requirements of the prime contract.

5. The 30% self-performance requirement of paragraph (1) is not applicable to design-build contracts; however, contracting agencies may establish their own self-performance requirements.

VII. SAFETY: ACCIDENT PREVENTION

This provision is applicable to all Federal-aid construction contracts and to all related subcontracts.

1. In the performance of this contract the contractor shall comply with all applicable Federal, State, and local laws governing safety, health, and sanitation (23 CFR 635). The contractor shall provide all safeguards, safety devices and protective equipment and take any other needed actions as it determines, or as the contracting officer may determine, to be reasonably necessary to protect the life and health of employees on the job and the safety of the public and to protect property in connection with the performance of the work covered by the contract.

2. It is a condition of this contract, and shall be made a condition of each subcontract, which the contractor enters into pursuant to this contract, that the contractor and any subcontractor shall not permit any employee, in performance of the contract, to work in surroundings or under conditions which are unsanitary, hazardous or dangerous to his/her health or safety, as determined under construction safety and health standards (29 CFR 1926) promulgated by the Secretary of Labor, in accordance with Section 107 of the Contract Work Hours and Safety Standards Act (40 U.S.C. 3704).

3. Pursuant to 29 CFR 1926.3, it is a condition of this contract that the Secretary of Labor or authorized representative thereof, shall have right of entry to any site of contract performance to inspect or investigate the matter of compliance with the construction safety and health standards and to carry out the duties of the Secretary under Section 107 of the Contract Work Hours and Safety Standards Act (40 U.S.C.3704).

VIII. FALSE STATEMENTS CONCERNING HIGHWAY PROJECTS

This provision is applicable to all Federal-aid construction contracts and to all related subcontracts.

In order to assure high quality and durable construction in conformity with approved plans and specifications and a high degree of reliability on statements and representations made by engineers, contractors, suppliers, and workers on Federal-aid highway projects, it is essential that all persons concerned with the project perform their functions as carefully, thoroughly, and honestly as

possible. Willful falsification, distortion, or misrepresentation with respect to any facts related to the project is a violation of Federal law. To prevent any misunderstanding regarding the seriousness of these and similar acts, Form FHWA-1022 shall be posted on each Federal-aid highway project (23 CFR 635) in one or more places where it is readily available to all persons concerned with the project:

18 U.S.C. 1020 reads as follows:

"Whoever, being an officer, agent, or employee of the United States, or of any State or Territory, or whoever, whether a person, association, firm, or corporation, knowingly makes any false statement, false representation, or false report as to the character, quality, quantity, or cost of the material used or to be used, or the quantity or quality of the work performed or to be performed, or the cost thereof in connection with the submission of plans, maps, specifications, contracts, or costs of construction on any highway or related project submitted for approval to the Secretary of Transportation; or

Whoever knowingly makes any false statement, false representation, false report or false claim with respect to the character, quality, quantity, or cost of any work performed or to be performed, or materials furnished or to be furnished, in connection with the construction of any highway or related project approved by the Secretary of Transportation; or

Whoever knowingly makes any false statement or false representation as to material fact in any statement, certificate, or report submitted pursuant to provisions of the Federal-aid Roads Act approved July 1, 1916, (39 Stat. 355), as amended and supplemented;

Shall be fined under this title or imprisoned not more than 5 years or both."

IX. IMPLEMENTATION OF CLEAN AIR ACT AND FEDERAL WATER POLLUTION CONTROL ACT

This provision is applicable to all Federal-aid construction contracts and to all related subcontracts.

By submission of this bid/proposal or the execution of this contract, or subcontract, as appropriate, the bidder, proposer, Federal-aid construction contractor, or subcontractor, as appropriate, will be deemed to have stipulated as follows:

1. That any person who is or will be utilized in the performance of this contract is not prohibited from receiving an award due to a violation of Section 508 of the Clean Water Act or Section 306 of the Clean Air Act.

2. That the contractor agrees to include or cause to be included the requirements of paragraph (1) of this Section X in every subcontract, and further agrees to take such action as the contracting agency may direct as a means of enforcing such requirements.

X. CERTIFICATION REGARDING DEBARMENT, SUSPENSION, INELIGIBILITY AND VOLUNTARY EXCLUSION

This provision is applicable to all Federal-aid construction contracts, design-build contracts, subcontracts, lower-tier subcontracts, purchase orders, lease agreements, consultant contracts or any other covered transaction requiring FHWA approval or that is estimated to cost \$25,000 or more – as defined in 2 CFR Parts 180 and 1200.

1. Instructions for Certification – First Tier Participants:

a. By signing and submitting this proposal, the prospective first tier participant is providing the certification set out below.

b. The inability of a person to provide the certification set out below will not necessarily result in denial of participation in this covered transaction. The prospective first tier participant shall submit an explanation of why it cannot provide the certification set out below. The certification or explanation will be considered in connection with the department or agency's determination whether to enter into this transaction. However, failure of the prospective first tier participant to furnish a certification or an explanation shall disqualify such a person from participation in this transaction.

c. The certification in this clause is a material representation of fact upon which reliance was placed when the contracting agency determined to enter into this transaction. If it is later determined that the prospective participant knowingly rendered an erroneous certification, in addition to other remedies available to the Federal Government, the contracting agency may terminate this transaction for cause of default.

d. The prospective first tier participant shall provide immediate written notice to the contracting agency to whom this proposal is submitted if any time the prospective first tier participant learns that its certification was erroneous when submitted or has become erroneous by reason of changed circumstances.

e. The terms "covered transaction," "debarred," "suspended," "ineligible," "participant," "person," "principal," and "voluntarily excluded," as used in this clause, are defined in 2 CFR Parts 180 and 1200. "First Tier Covered Transactions" refers to any covered transaction between a grantee or subgrantee of Federal funds and a participant (such as the prime or general contract). "Lower Tier Covered Transactions" refers to any covered transaction under a First Tier Covered Transaction (such as subcontracts). "First Tier Participant" refers to the participant who has entered into a covered transaction with a grantee or subgrantee of Federal funds (such as the prime or general contractor). "Lower Tier Participant" refers any participant who has entered into a covered transaction with a First Tier Participant or other Lower Tier Participants (such as subcontractors and suppliers).

f. The prospective first tier participant agrees by submitting this proposal that, should the proposed covered transaction be entered into, it shall not knowingly enter into any lower tier covered transaction with a person who is debarred, suspended, declared ineligible, or voluntarily excluded from participation in this covered transaction, unless authorized by the department or agency entering into this transaction.

g. The prospective first tier participant further agrees by submitting this proposal that it will include the clause titled "Certification Regarding Debarment, Suspension, Ineligibility and Voluntary Exclusion-Lower Tier Covered Transactions," provided by the department or contracting agency, entering into this covered transaction, without modification, in all lower tier covered transactions and in all solicitations for lower tier covered transactions exceeding the \$25,000 threshold.

h. A participant in a covered transaction may rely upon a certification of a prospective participant in a lower tier covered transaction that is not debarred, suspended, ineligible, or voluntarily excluded from the covered transaction, unless it knows that the certification is erroneous. A participant is responsible for ensuring that its principals are not suspended, debarred, or otherwise ineligible to participate in covered transactions. To verify the eligibility of its principals, as well as the eligibility of any lower tier prospective participants, each participant may, but is not required to, check the Excluded Parties List System website (<https://www.epls.gov/>), which is compiled by the General Services Administration.

i. Nothing contained in the foregoing shall be construed to require the establishment of a system of records in order to render in good faith the certification required by this clause. The knowledge and information of the prospective participant is not required to exceed that which is normally possessed by a prudent person in the ordinary course of business dealings.

j. Except for transactions authorized under paragraph (f) of these instructions, if a participant in a covered transaction knowingly enters into a lower tier covered transaction with a person who is suspended, debarred, ineligible, or voluntarily excluded from participation in this transaction, in addition to other remedies available to the Federal Government, the department or agency may terminate this transaction for cause or default.

* * * * *

2. Certification Regarding Debarment, Suspension, Ineligibility and Voluntary Exclusion – First Tier Participants:

a. The prospective first tier participant certifies to the best of its knowledge and belief, that it and its principals:

(1) Are not presently debarred, suspended, proposed for debarment, declared ineligible, or voluntarily excluded from participating in covered transactions by any Federal department or agency;

(2) Have not within a three-year period preceding this proposal been convicted of or had a civil judgment rendered against them for commission of fraud or a criminal offense in connection with obtaining, attempting to obtain, or performing a public (Federal, State or local) transaction or contract under a public transaction; violation of Federal or State antitrust statutes or commission of embezzlement, theft, forgery, bribery, falsification or destruction of records, making false statements, or receiving stolen property;

(3) Are not presently indicted for or otherwise criminally or civilly charged by a governmental entity (Federal, State or local) with commission of any of the offenses enumerated in paragraph (a)(2) of this certification; and

(4) Have not within a three-year period preceding this application/proposal had one or more public transactions (Federal, State or local) terminated for cause or default.

b. Where the prospective participant is unable to certify to any of the statements in this certification, such prospective participant shall attach an explanation to this proposal.

2. Instructions for Certification -Lower Tier Participants:

(Applicable to all subcontracts, purchase orders and other lower tier transactions requiring prior FHWA approval or estimated to cost \$25,000 or more -2 CFR Parts 180 and 1200)

a. By signing and submitting this proposal, the prospective lower tier is providing the certification set out below.

b. The certification in this clause is a material representation of fact upon which reliance was placed when this transaction was entered into. If it is later determined that the prospective lower tier participant knowingly rendered an erroneous certification, in addition to other remedies available to the Federal Government, the department, or agency with which this transaction originated may pursue available remedies, including suspension and/or debarment.

c. The prospective lower tier participant shall provide immediate written notice to the person to which this proposal is submitted if at any time the prospective lower tier participant learns that its certification was erroneous by reason of changed circumstances.

d. The terms "covered transaction," "debarred," "suspended," "ineligible," "participant," "person," "principal," and "voluntarily excluded," as used in this clause, are defined in 2 CFR Parts 180 and 1200. You may contact the person to which this proposal is submitted for assistance in obtaining a copy of those regulations. "First Tier Covered Transactions" refers to any covered transaction between a grantee or subgrantee of Federal funds and a participant (such as the prime or general contract). "Lower Tier Covered Transactions" refers to any covered transaction under a First Tier Covered Transaction (such as subcontracts). "First Tier

Participant" refers to the participant who has entered into a covered transaction with a grantee or subgrantee of Federal funds (such as the prime or general contractor). "Lower Tier Participant" refers any participant who has entered into a covered transaction with a First Tier Participant or other Lower Tier Participants (such as subcontractors and suppliers).

e. The prospective lower tier participant agrees by submitting this proposal that, should the proposed covered transaction be entered into, it shall not knowingly enter into any lower tier covered transaction with a person who is debarred, suspended, declared ineligible, or voluntarily excluded from participation in this covered transaction, unless authorized by the department or agency with which this transaction originated.

f. The prospective lower tier participant further agrees by submitting this proposal that it will include this clause titled "Certification Regarding Debarment, Suspension, Ineligibility and Voluntary Exclusion-Lower Tier Covered Transaction," without modification, in all lower tier covered transactions and in all solicitations for lower tier covered transactions exceeding the \$25,000 threshold.

g. A participant in a covered transaction may rely upon a certification of a prospective participant in a lower tier covered transaction that is not debarred, suspended, ineligible, or voluntarily excluded from the covered transaction, unless it knows that the certification is erroneous. A participant is responsible for ensuring that its principals are not suspended, debarred, or otherwise ineligible to participate in covered transactions. To verify the eligibility of its principals, as well as the eligibility of any lower tier prospective participants, each participant may, but is not required to, check the Excluded Parties List System website (<https://www.epls.gov/>), which is compiled by the General Services Administration.

h. Nothing contained in the foregoing shall be construed to require establishment of a system of records in order to render in good faith the certification required by this clause. The knowledge and information of participant is not required to exceed that which is normally possessed by a prudent person in the ordinary course of business dealings.

i. Except for transactions authorized under paragraph e of these instructions, if a participant in a covered transaction knowingly enters into a lower tier covered transaction with a person who is suspended, debarred, ineligible, or voluntarily excluded from participation in this transaction, in addition to other remedies available to the Federal Government, the department or agency with which this transaction originated may pursue available remedies, including suspension and/or debarment.

* * * * *

Certification Regarding Debarment, Suspension, Ineligibility and Voluntary Exclusion--Lower Tier Participants:

1. The prospective lower tier participant certifies, by submission of this proposal, that neither it nor its principals is presently debarred, suspended, proposed for debarment, declared ineligible, or voluntarily excluded from participating in covered transactions by any Federal department or agency.

2. Where the prospective lower tier participant is unable to certify to any of the statements in this certification, such prospective participant shall attach an explanation to this proposal.

* * * * *

XI. CERTIFICATION REGARDING USE OF CONTRACT FUNDS FOR LOBBYING

This provision is applicable to all Federal-aid construction contracts and to all related subcontracts which exceed \$100,000 (49 CFR 20).

1. The prospective participant certifies, by signing and submitting this bid or proposal, to the best of his or her knowledge and belief, that:

a. No Federal appropriated funds have been paid or will be paid, by or on behalf of the undersigned, to any person for influencing or attempting to influence an officer or employee of any Federal agency, a Member of Congress, an officer or employee of Congress, or an employee of a Member of Congress in connection with the awarding of any Federal contract, the making of any Federal grant, the making of any Federal loan, the entering into of any cooperative agreement, and the extension, continuation, renewal, amendment, or modification of any Federal contract, grant, loan, or cooperative agreement.

b. If any funds other than Federal appropriated funds have been paid or will be paid to any person for influencing or attempting to influence an officer or employee of any Federal agency, a Member of Congress, an officer or employee of Congress, or an employee of a Member of Congress in connection with this Federal contract, grant, loan, or cooperative agreement, the undersigned shall complete and submit Standard Form-LLL, "Disclosure Form to Report Lobbying," in accordance with its instructions.

2. This certification is a material representation of fact upon which reliance was placed when this transaction was made or entered into. Submission of this certification is a prerequisite for making or entering into this transaction imposed by 31 U.S.C. 1352. Any person who fails to file the required certification shall be subject to a civil penalty of not less than \$10,000 and not more than \$100,000 for each such failure.

3. The prospective participant also agrees by submitting its bid or proposal that the participant shall require that the language of this certification be included in all lower tier subcontracts, which exceed \$100,000 and that all such recipients shall certify and

disclose accordingly.

ATTACHMENT A -EMPLOYMENT AND MATERIALS PREFERENCE FOR APPALACHIAN DEVELOPMENT HIGHWAY SYSTEM OR APPALACHIAN LOCAL ACCESS ROAD CONTRACTS

This provision is applicable to all Federal-aid projects funded under the Appalachian Regional Development Act of 1965.

1. During the performance of this contract, the contractor undertaking to do work which is, or reasonably may be, done as on-site work, shall give preference to qualified persons who regularly reside in the labor area as designated by the DOL wherein the contract work is situated, or the subregion, or the Appalachian counties of the State wherein the contract work is situated, except:

a. To the extent that qualified persons regularly residing in the area are not available.

b. For the reasonable needs of the contractor to employ supervisory or specially experienced personnel necessary to assure an efficient execution of the contract work.

c. For the obligation of the contractor to offer employment to present or former employees as the result of a lawful collective bargaining contract, provided that the number of nonresident persons employed under this subparagraph (1c) shall not exceed 20 percent of the total number of employees employed by the contractor on the contract work, except as provided in subparagraph (4) below.

2. The contractor shall place a job order with the State Employment Service indicating (a) the classifications of the laborers, mechanics and other employees required to perform the contract work, (b) the number of employees required in each classification, (c) the date on which the participant estimates such employees will be required, and (d) any other pertinent information required by the State Employment Service to complete the job order form. The job order may be placed with the State Employment Service in writing or by telephone. If during the course of the contract work, the information submitted by the contractor in the original job order is substantially modified, the participant shall promptly notify the State Employment Service.

3. The contractor shall give full consideration to all qualified job applicants referred to him by the State Employment Service. The contractor is not required to grant employment to any job applicants who, in his opinion, are not qualified to perform the classification of work required.

4. If, within one week following the placing of a job order by the contractor with the State Employment Service, the State Employment Service is unable to refer any qualified job applicants to the contractor, or less than the number requested, the State Employment Service will forward a certificate to the contractor indicating the unavailability of applicants. Such certificate shall be made a part of the contractor's permanent project records. Upon receipt of this certificate, the contractor may employ persons who do not normally reside in the labor area to fill positions covered by the certificate, notwithstanding the provisions of subparagraph (1c) above.

5. The provisions of 23 CFR 633.207(e) allow the contracting agency to provide a contractual preference for the use of mineral resource materials native to the Appalachian region.

6. The contractor shall include the provisions of Sections 1 through 4 of this Attachment A in every subcontract for work which is, or reasonably may be, done as on-site work.

100-C-151B DISADVANTAGED BUSINESS ENTERPRISE PROCEDURE AND GOOD FAITH EFFORTS

(Revised 04-15-14)

The Standard Specifications are revised as follows:

SECTION 103, BEGIN LINE 1, DELETE AND INSERT AS FOLLOWS:

SECTION 103 – AWARD AND EXECUTION OF CONTRACT

103.01 Disadvantaged Business Enterprise Program

This requirement will apply only to a federal aid contract.

(a) General Requirements

Failure to carry out the requirements set forth in 49 CFR ~~23.43(a)~~ 26, *as outlined in the Department's DBE Program Manual*, shall constitute a breach of contract and, after notification,

may result in ~~termination of the contract or such remedy as the State deems appropriate~~ such contract sanctions as the Department or the Federal Highway Administration may determine to be appropriate, including, but not limited to: (a) withholding of payments to the Contractor under the contract until the Contractor complies, and/or (b) cancellation, termination or suspension of the contract, in whole or in part.

The above referenced CFR section requires the following policy and disadvantaged business enterprise obligation to be included in all subsequent agreements between the Contractor and all subcontractors as follows:

1. It will be the policy of the Department ~~that disadvantaged business enterprises, as defined in 49 CFR Part 23, shall have the maximum opportunity to participate in the performance of contract work financed in whole or in part with Federal funds provided under this contract to create a level playing field on which DBE's can compete fairly for federally funded contracts.~~ Consequently, the disadvantaged business enterprise requirements of 49 CFR Part ~~23~~26, as outlined in the Department's DBE Program Manual, apply to this contract.
2. ~~The Contractor agrees to ensure that disadvantaged business enterprises certified by the State shall have the maximum opportunity to participate in the performance of contract work or subcontract work financed in whole or in part with Federal funds provided under this contract. In this regard, the Contractor shall take all necessary and reasonable steps, in accordance with 49 CFR Part 23, to ensure that disadvantaged business enterprises have the maximum opportunity to compete for and perform work in this contract. The Contractor shall not discriminate on the basis of race, color, national origin, or sex, in the award and performance of this contract. The Contractor shall carry out the applicable DBE requirements in the award and administration of federally funded contracts. Failure by the Contractor to carry out these requirements is a material breach of this contract which may result in the termination of this contract or such other remedy as the Department or the Federal Highway Administration deems appropriate. The Contractor shall include language prohibiting discrimination on the basis of race, color, national origin, or sex in the performance of this contract in all subcontracts.~~

SECTION 103, BEGIN LINE 59, DELETE AND INSERT AS FOLLOWS:

4. Certified DBE

A business enterprise which has completed and filed a request for certification with the ~~Indiana Department of Administration~~, and that the business enterprise has been reviewed and determined to comply with the guidelines established in 49 CFR Part ~~23~~26. Business enterprises which are determined to be eligible will be certified as DBEs *to perform specific types of work*.

(c) Goal

A contract provision *DBE* goal may be shown on the Proposal sheet. Such goal, if required, has been established as the *desired minimum* amount to be contracted to DBEs. The Contractor shall meet or exceed the goal, or demonstrate that it could not be met despite ~~best~~

good faith efforts. Achievement of the ~~contract provision~~ goal does not relieve the Contractor of the requirement for affirmative action on subsequent subcontracting on this contract. Only work with listed DBEs ~~which~~ that are certified prior to the date of the letting will count toward the goal. Credit towards contract goals will be given only for work performed by certified DBEs in the work areas for which they have been certified. The same requirements with respect to obtaining the goal apply for a Contractor that is certified as a DBE. A DBE Contractor must either achieve the goal utilizing other DBE firms or demonstrate that the goal could not be met despite good faith efforts.

Contracting may be in the form of a subcontract, lease agreement, or material supply agreement. ~~Full~~Prime contractors will receive 100% credit ~~will be given~~ for work done by the DBE under subcontracts and lease agreements. Credit for utilization of a DBE material supplier will be limited to those DBEs certified as suppliers prior to the letting at the rate of 60% of the expenditure to the supplier unless the supplier is also the manufacturer. ~~agreement depends on whether the supplier is a manufacturer, regular dealer or broker. Full credit will be given for suppliers who manufacture the items and are certified as Supplier Manufacturer in the DBE repository. Credit will be limited to 60% of the expenditure for suppliers acting as a regular dealer and are certified as Supplier Regular Dealer in the DBE repository. Credit will be limited to fees and commissions for suppliers acting as a broker and are certified as Supplier Broker in the DBE repository. Suppliers that do not manufacture the items shall also perform a commercially useful function in order for credit to be received.~~

A written request for changes in utilization of race/gender conscious DBE firms listed in the Affirmative Action Certification shall be approved prior to start of listed services or purchase of listed materials. Requests to reduce or eliminate the services or material provided by a listed race/gender conscious DBE that include written approval by the DBE will be considered sufficient justification if the committed DBE utilization after the requested change will meet or exceed the contract goal or a lesser percentage approved prior to execution of the contract. If the committed DBE utilization after the change does not meet or exceed the contract goal or a lesser percentage approved prior to execution of the contract, or the listed race/gender conscious DBE does not approve the change, the Contractor shall submit documented evidence that the DBE is unable to perform successfully. Disposition of the request for change will be determined on the basis of the affirmative actions taken as required herein.

When a race/gender conscious DBE firm is removed from eligibility, the Contractor shall take the following steps:

- 1. If a subcontract has not yet been executed, the Contractor shall not count work performed by the firm toward the contract goal. The Contractor will be directed to meet the contract goal with an eligible DBE firm or demonstrate that it has made a good faith effort to do so.*
- 2. If a subcontract has been executed before the firm has been declared ineligible, the Contractor shall continue to count work performed by the firm toward the contract goal.*

SECTION 103, DELETE LINES 102 THROUGH 119.

SECTION 103, DELETE LINES 143 THROUGH 241.

SECTION 103, AFTER LINE 242, INSERT AS FOLLOWS:

(e) Determination of Good Faith Efforts

Appendix A of 49 CFR Part 26 has been used for guidance in preparing the Department's procedures to determine the adequacy of good faith efforts. Additional factors consistent with 49 CFR Part 26, and the Department's policies and procedures have also been utilized.

1. Good Faith Efforts Prior to Award

The following factors will be considered in determining good faith efforts prior to award of a contract. The Contractor, including DBE Contractors, shall submit evidence on each of the factors.

- a. The Contractor shall make reasonable effort to contact all ready, willing, and able DBEs who express a desire to work on any of the pay items of the contract.*
- b. To effectively participate, the DBE shall have the opportunity to analyze the contract and submit quotations prior to letting. Information provided by the Contractor to the DBEs shall include, at a minimum, the contract number, pay items, quantities for those pay items to be subcontracted, and the date the subcontract bid is desired.*
- c. The Contractor shall select the portions of the work to be performed by DBEs in order to increase the likelihood of DBE participation. This shall include, where appropriate, an attempt to break down the contract into economically feasible units to facilitate DBE participation.*
- d. The Contractor shall provide the interested DBEs with complete information about the plans, specifications, and requirements of the contract. Attempts shall be made to have plans available or to notify the DBE of the location of available plans. The Contractor shall notify the DBE of revisions to the contract.*
- e. It will be considered unacceptable to avoid subcontracting to DBEs if such subcontracting to DBEs results in the need to further subdivide remaining work items.*
- f. The Contractor shall negotiate in good faith with interested DBEs and not reject such DBEs as unqualified without sound reasons based on thorough investigation of their capabilities. Confirmed documentation that a DBE has not been able to perform previous work through no fault of others will be considered to be sound reason. Unacceptable criteria include, but are not limited to, unsubstantiated oral statements and unsigned documentation.*

- g. The Contractor shall make efforts to assist interested DBEs in obtaining bonding, lines of credit, or insurance required by the State. However, the Contractor shall affirmatively consider waiving requirements it may have in order to assist the DBE.*
- h. Only firms certified as DBEs prior to the letting date can be used to meet the contract goal for the Department's DBE program.*

The Contractor will be considered to have made good faith efforts if it either:

- a. Documents that it has obtained enough DBE participation to meet the goal, or*
- b. Documents that it made adequate good faith efforts in accordance with the factors set out above to meet the goal even though it did not succeed in obtaining enough DBE participation to do so.*

If a DBE goal has been established for the contract, the Contractor shall take good faith efforts to achieve the established goal prior to the bid opening. The Affirmative Action Certification shall be completed and submitted with the Proposal Book to indicate both race/gender conscious and race/gender neutral proposed DBE utilization.

The award of the contract will be made to the lowest and best bidder when all other requirements have been met and good faith efforts have been taken toward meeting the DBE goal, if required, in accordance with these requirements.

If the apparent low bidder has not achieved the contract DBE goal, the bidder shall respond in writing within five business days after notification by the Department of the failure to meet the DBE goal. The response shall provide evidence identifying the bidder's good faith efforts and all affirmative actions taken prior to letting to achieve the required DBE goal. Failure to respond within the five business day period will result in rejection of the bid, and may result in forfeiture of the bid bond, and the referral of the bidder to the Prequalification Committee.

Responses shall be sent to the Department's Division of Contract Administration. The Department will review the bidder's good faith efforts for compliance with these requirements.

If the Department determines that adequate good faith efforts have been made, and the bidder has met all other bidding requirements, the contract will be awarded.

If the Department determines that good faith efforts were inadequate, the Department will issue written notification of the determination to the bidder. The determination will outline the reasons for determination of non-compliance with good faith effort requirements.

The bidder may request a review of a determination of non-compliance by making a

written submittal within five business days of the bidder's receipt of notification of non-compliance from the Department. The request for review shall include evidence disputing the Department's reasons for issuing a determination of non-compliance. The request shall be sent to the Department's Division of Contract Administration.

Upon receipt of a request, the Department will contact the bidder to schedule a review. The review will be held by the Department's Deputy Commissioner and Chief Counsel, or a designee who did not participate in the original determination of non-compliance. The review will be conducted in accordance with the Department's policy for review of good faith efforts requirements. A copy of the policy is available on the Department's website or through the Division of Contract Administration.

If the Deputy Commissioner's finding determines that the bidder's good faith efforts were adequate, and the bidder has met all other bidding requirements, the contract will be awarded and the Department will adjust the contract time by the number of calendar days from the date of the original determination of non-compliance to and including the date of the Deputy Commissioner's findings.

If the Deputy Commissioner's finding determines that the bidder's good faith efforts were inadequate, the finding will be forwarded to the Commissioner. The Commissioner will review the Deputy Commissioner's finding and issue a written Contract Award Determination.

If the Commissioner's Contract Award Determination finds that the bidder's good faith efforts were adequate, and the bidder has met all other bidding requirements, the contract will be awarded and the Department will adjust the contract time by the number of calendar days from the start of the original determination of non-compliance to and including the date of the Commissioner's determination.

If the Commissioner's Contract Award Determination finds that the bidder's good faith efforts were inadequate, at the Commissioner's sole option and without further proceedings, either all bids will be rejected or the contract will be awarded to the next lowest and qualified bidder. An apparent low bidder who has not met the DBE goal and requirements for good faith efforts may be requested not to rebid on this contract during subsequent lettings.

The Commissioner's Contract Award Determination will be the final decision of the Department.

2. Good Faith Efforts for Extra Work

When extra work in accordance with 104.03 is added to a contract with a DBE goal, the Contractor shall hire or make good faith efforts to hire a DBE subcontractor to perform significant extra work.

For purposes of DBE good faith efforts, significant extra work is defined as new pay items added to a Contract that result in a new contracting opportunity not reasonably related to existing pay items being performed by the Contractor or a subcontractor.

When significant extra work related to existing pay items being performed by a DBE subcontractor is added to a contract with a DBE goal, the Contractor shall offer that same DBE subcontractor the opportunity to perform the extra work whether or not the existing pay items are counted toward the DBE goal. The Contractor shall consider other DBE subcontractors if the extra work would result in the original DBE subcontractor exceeding its prequalification limits. The Department may consider an exception to a DBE subcontractor's prequalification limit. If the DBE subcontractor is unable to perform the extra work, the Contractor shall hire or make good faith efforts to hire an alternate DBE subcontractor to perform the work.

When significant extra work related to existing pay items being performed by a non-DBE subcontractor is added to a contract with a DBE goal, the non-DBE subcontractor may perform the extra work. If the non-DBE subcontractor is unable to perform the extra work, the Contractor may self-perform the extra work. If the Contractor chooses not to self-perform the extra work, the Contractor shall hire or make good faith efforts to hire a DBE firm to perform the work.

When significant extra work related to existing pay items being performed by the Contractor is added to a contract with a DBE goal, the Contractor may self-perform the extra work. If the Contractor chooses not to self-perform the extra work, the Contractor shall hire or make good faith efforts to hire a DBE firm to perform the work.

The Contractor shall forward documentation of good faith efforts to hire a DBE subcontractor to perform extra work to the District Equal Employment Opportunity, EEO, Officer for review. The EEO Officer will determine if good faith efforts have been met in accordance with 103.01(e)1.

If the EEO Officer determines that the Contractor failed to make good faith efforts to hire a DBE firm when required as a result of significant extra work, written notice will be sent to the Contractor. The Contractor may appeal the determination in accordance with 103.01(e)1.

(f) Affirmative Action Certification

The Affirmative Action Certification, included in the Proposal book, shall be completed when the Proposal book is submitted to the Department. The certification shall list ~~DBEs or shall state the reasons DBEs are not listed~~ all DBE firms the Contractor plans to utilize, either race/gender consciously or race/gender neutrally. Blank certifications shall cause the bid to be rejected. If a portion of a pay item is to be performed by a DBE, an explanation shall be included stating exactly what the DBE is performing or supplying. Failure to do so may affect the award of the contract. *The Contractor shall ensure that DBE firms listed on the Affirmative Action Certification are certified DBE firms as listed in the Department's DBE directory at the time of letting. In addition to the listing of DBE firms that will be used race/gender consciously to meet the goal, the Contractor shall also provide a total for the amount of work that it anticipates will be performed by other DBE firms used race/gender neutrally on the contract beyond the goal requirements.*

Race/gender neutral awards involve the utilization of a DBE firm because the DBE firm is the best firm to perform the work. Race/gender conscious awards involve the utilization of a

DBE firm primarily to achieve the contract DBE goal.

SECTION 103, BEGIN LINE 281, DELETE AND INSERT AS FOLLOWS:

In order to perform a commercially useful function on a contract, the dollar volume of hauling by a DBE trucking firm that is counted toward the DBE goal is limited to the total value of transportation services provided by the DBE's own trucks; the total value of transportation services a DBE lessee provides with its own trucks; and the total value of transportation services a non-DBE lessee provides with its own trucks, not to exceed the value of transportation services provided by DBE-owned trucks that dollar volume of hauling attributable to a maximum of twice the number of vehicles owned by the DBE, or leased from another DBE, that are utilized on the project. DBE hauling lessors who sublease a portion of their hauling shall take positive affirmative actions to sublease to DBEs and shall provide Form MBE-2 to the Department, evidencing those efforts prior to commencing work. In addition, DBE credit will also be given for any fee or commission the non-DBE lessee receives as a result of the lease arrangement for any additional non-DBE trucks.

In order to count leased trucks toward the goal, the lease must indicate that the DBE has exclusive use of and control over the truck. This does not preclude the leased truck from being used by others during the term of the lease with the consent of the DBE, so long as the lease gives the DBE absolute priority for use of the leased truck. Leased trucks must display the name and identification number of the DBE. The DBE must be responsible for the management and supervision of the entire trucking operation for which it is responsible on a particular contract, and there cannot be a contrived arrangement for the purpose of meeting the DBE goals.

The Contractor shall provide the Engineer copies of any lease agreements between DBE trucking subcontractors and any DBE or non-DBE trucking firms or owner/operators that will be used to supplement the DBE trucking subcontractor's trucks for the purpose of meeting the DBE goal. Copies of these lease agreements shall be provided by the time of use of any supplemental trucks on the Contract.

In addition to delivery ticket information required by Section 106, the following information shall be included on each ticket for material delivered to the job site by a DBE trucking subcontractor or lessee:

- 1. Name of trucking firm*
- 2. Printed name of the driver*

The Contractor shall submit weekly reports to the Engineer on forms provided by the Department, documenting the number of DBE trucks utilized and a breakdown of the dollar amount credited toward the Contract DBE goal. The reports shall be submitted within five business days of the end of the week being reported. Forms are available on the Department's website or from the Division of Contract Administration.

SECTION 103, BEGIN LINE 303, DELETE AND INSERT AS FOLLOWS:

(i) Records and Reports

The Contractor shall keep such records as necessary to determine compliance with its DBE utilization obligations and compliance with the Guidelines for Determining of Good Faith

Efforts for ~~Goal Contracts~~. The records kept by the Contractor shall indicate the minimum requirements as follows:

100-C-151C DBE AND NON-DBE GOAL CONTRACTS RECORD KEEPING AND TIMELY PAY

(Revised 04-15-14)

SECTION 103, BEGIN LINE 264, DELETE AND INSERT AS FOLLOWS:

~~Requests to subcontract a portion of the work to a firm that is not a DBE shall include Form MBE-2. Documentation shall be submitted evidencing contacts and the results thereof with potential DBEs for the specific work to be subcontracted.~~

Upon receipt of notification from the Department, a Disadvantaged Business Enterprise Utilization Affidavit, Form ~~MBE-3~~DBE-3, shall be completed by the Contractor and returned to the Department. The Contractor and the subcontractor/lessor/supplier shall certify on Form ~~MBE-3~~DBE-3 that specific amounts have been paid and received. *A DBE-3 Form certification shall be completed and submitted for every DBE utilized on the contract, whether there was a DBE contract goal or not.*

SECTION 103, AFTER LINE 340, INSERT AS FOLLOWS:

103.02.1 Record Keeping

All firms performing work on Department contracts, bidding on Department contracts, or offering quotes for subcontract or trucking services shall register with the Department, annually, by submitting the following information to the Department's Prequalification Engineer.

- (a) *firm's name;*
- (b) *firm's address;*
- (c) *firm's status as a DBE or non-DBE;*
- (d) *the age of the firm; and*
- (e) *the annual gross receipts of the firm*
- (f) *in which of the following markets has the firm participated?*
 - 1. *prime Contractor*
 - 2. *subcontractor*
 - 3. *hauler*
 - 4. *consultant*
 - 5. *supplier*

100-C-151D EXECUTIVE ORDER 11246

(Revised 04-15-14)

The Standard Specifications are revised as follows:

SECTION 103, BEGIN LINE 341, DELETE AND INSERT AS FOLLOWS:

103.03 ~~Blank~~Equal Employment Opportunity**(a) Notice of Requirement for Affirmative Action to Ensure Equal Employment Opportunity (Executive Order 11246)**

1. *The Offeror's or Bidder's attention is called to the "Equal Opportunity Clause" and the "Standard Federal Equal Employment Specifications" set forth herein.*
2. *The goals and timetables for minority and female participation, expressed in percentage terms for the Contractor's aggregate workforce in each trade on all construction work in the covered area, are as follows:*

a. Minority Hiring Goals by County

<i>COUNTY</i>	<i>PCT.</i>	<i>COUNTY</i>	<i>PCT.</i>	<i>COUNTY</i>	<i>PCT.</i>
<i>Adams</i>	<i>4.4</i>	<i>Hendricks</i>	<i>12.5</i>	<i>Pike</i>	<i>3.5</i>
<i>Allen</i>	<i>4.4</i>	<i>Henry</i>	<i>3.9</i>	<i>Porter</i>	<i>20.9</i>
<i>Bartholomew</i>	<i>9.7</i>	<i>Howard</i>	<i>4.4</i>	<i>Posey</i>	<i>4.8</i>
<i>Benton</i>	<i>1.5</i>	<i>Huntington</i>	<i>4.4</i>	<i>Pulaski</i>	<i>18.4</i>
<i>Blackford</i>	<i>3.9</i>	<i>Jackson</i>	<i>9.7</i>	<i>Putnam</i>	<i>9.7</i>
<i>Boone</i>	<i>12.5</i>	<i>Jasper</i>	<i>18.4</i>	<i>Randolph</i>	<i>3.9</i>
<i>Brown</i>	<i>9.7</i>	<i>Jay</i>	<i>3.9</i>	<i>Ripley</i>	<i>9.2</i>
<i>Carroll</i>	<i>1.5</i>	<i>Jefferson</i>	<i>9.6</i>	<i>Rush</i>	<i>9.7</i>
<i>Cass</i>	<i>3.7</i>	<i>Jennings</i>	<i>9.7</i>	<i>St. Joseph</i>	<i>7.1</i>
<i>Clark</i>	<i>11.2</i>	<i>Johnson</i>	<i>12.5</i>	<i>Scott</i>	<i>9.6</i>
<i>Clay</i>	<i>3.1</i>	<i>Knox</i>	<i>3.5</i>	<i>Shelby</i>	<i>12.5</i>
<i>Clinton</i>	<i>1.5</i>	<i>Kosciusko</i>	<i>6.2</i>	<i>Spencer</i>	<i>3.5</i>
<i>Crawford</i>	<i>9.6</i>	<i>LaGrange</i>	<i>6.2</i>	<i>Starke</i>	<i>18.4</i>
<i>Daviess</i>	<i>9.7</i>	<i>Lake</i>	<i>20.9</i>	<i>Steuben</i>	<i>4.4</i>
<i>Dearborn</i>	<i>11.0</i>	<i>LaPorte</i>	<i>18.4</i>	<i>Sullivan</i>	<i>3.1</i>
<i>Decatur</i>	<i>9.7</i>	<i>Lawrence</i>	<i>9.7</i>	<i>Switzerland</i>	<i>9.2</i>
<i>Dekalb</i>	<i>4.4</i>	<i>Madison</i>	<i>4.9</i>	<i>Tippecanoe</i>	<i>2.7</i>
<i>Delaware</i>	<i>5.3</i>	<i>Marion</i>	<i>12.5</i>	<i>Tipton</i>	<i>4.4</i>
<i>Dubois</i>	<i>3.5</i>	<i>Marshall</i>	<i>7.1</i>	<i>Union</i>	<i>3.9</i>
<i>Elkhart</i>	<i>4.0</i>	<i>Martin</i>	<i>9.7</i>	<i>Vanderburgh</i>	<i>4.8</i>
<i>Fayette</i>	<i>3.9</i>	<i>Miami</i>	<i>3.7</i>	<i>Vermillion</i>	<i>3.1</i>
<i>Floyd</i>	<i>11.2</i>	<i>Monroe</i>	<i>3.1</i>	<i>Vigo</i>	<i>3.1</i>
<i>Fountain</i>	<i>1.5</i>	<i>Montgomery</i>	<i>1.5</i>	<i>Wabash</i>	<i>3.7</i>
<i>Franklin</i>	<i>9.2</i>	<i>Morgan</i>	<i>12.5</i>	<i>Warren</i>	<i>1.5</i>
<i>Fulton</i>	<i>6.2</i>	<i>Newton</i>	<i>18.4</i>	<i>Warrick</i>	<i>4.8</i>
<i>Gibson</i>	<i>4.8</i>	<i>Noble</i>	<i>4.4</i>	<i>Washington</i>	<i>9.6</i>
<i>Grant</i>	<i>3.7</i>	<i>Ohio</i>	<i>9.2</i>	<i>Wayne</i>	<i>3.9</i>
<i>Greene</i>	<i>9.7</i>	<i>Orange</i>	<i>9.6</i>	<i>Wells</i>	<i>4.4</i>
<i>Hamilton</i>	<i>12.5</i>	<i>Owen</i>	<i>9.7</i>	<i>White</i>	<i>1.5</i>
<i>Hancock</i>	<i>12.5</i>	<i>Parke</i>	<i>2.5</i>	<i>Whitley</i>	<i>4.4</i>

Harrison 9.6 Perry 3.5

- b. Female Hiring Goal.** *The female hiring goal is 6.9% throughout the State. Minority females may be counted both as a minority and as a female.*

These goals are applicable to all the Contractor's construction work (whether or not it is Federal or federally assisted) performed in the covered area. If the contractor performs construction work in a geographical area located outside of the covered area, it shall apply the goals established for such geographical area where the work is actually performed. With regard to this second area, the contract also is subject to the goals for both its federally involved and non-federally involved construction.

The Contractor's compliance with the Executive Order and the regulations in 41 CFR part 60-4 shall be based on its implementation of the Equal Opportunity Clause, specific affirmative action obligations required by the specifications set forth in 41 CFR 60-4.3(a), and its efforts to meet the goals. The hours of minority and female employment and training must be substantially uniform throughout the length of the contract, and in each trade, and the contractor shall make a good faith effort to employ minorities and women evenly on each of its projects. The transfer of minority or female employees or trainees from Contractor to Contractor or from project to project for the sole purpose of meeting the Contractor's goals shall be a violation of the contract, the Executive Order and the regulations in 41 CFR part 60-4. Compliance with the goals will be measured against the total work hours performed.

3. *The Contractor shall provide written notification to the Director of the Office of Federal Contract Compliance Programs with 10 working days of award of any construction subcontract in excess of \$10,000 at any tier for construction work under the contract resulting from this solicitation. The notification shall list the name, address and telephone number of the subcontractor; employer identification number of the subcontractor; estimated dollar amount of the subcontract; estimated starting and completion dates of the subcontract; and the geographical area in which the subcontract is to be performed.*
4. *As used in this Notice, and in the contract resulting from this solicitation, the "covered area" as shown in the contract documents.*

(b) Equal Opportunity Clause

The applicant hereby agrees that it will incorporate or cause to be incorporated into any contract for construction work, or modification thereof, as defined in the regulations of the Secretary of Labor at 41 CFR Chapter 60, which is paid for in whole or in part with funds obtained from the Federal Government or borrowed on the credit of the Federal Government pursuant to a grant, contract, loan, insurance, or guarantee, or undertaken pursuant to any Federal program involving such grant, contract, loan, insurance, or guarantee, the following equal opportunity clause:

During the performance of this contract, the contractor agrees as follows:

- (1) *The contractor will not discriminate against any employee or applicant for employment because of race, color, religion, sex, or national origin. The contractor will take affirmative action to ensure that applicants are employed, and that employees are treated during employment without regard to their race, color, religion, sex, or national origin. Such action shall include, but not be limited to the following: employment, upgrading, demotion, or transfer; recruitment or recruitment advertising; layoff or termination; rates of pay or other forms of compensation; and selection for training, including apprenticeship. The contractor agrees to post in conspicuous places, available to employees and applicants for employment, notices to be provided setting forth the provisions of this nondiscrimination clause.*
- (2) *The contractor will, in all solicitations or advertisements for employees placed by or on behalf of the contractor, state that all qualified applicants will receive considerations for employment without regard to race, color, religion, sex, or national origin.*
- (3) *The contractor will send to each labor union or representative of workers with which he has a collective bargaining agreement or other contract or understanding, a notice to be provided advising the said labor union or workers' representatives of the contractor's commitments under this section, and shall post copies of the notice in conspicuous places available to employees and applicants for employment.*
- (4) *The contractor will comply with all provisions of Executive Order 11246 of September 24, 1965, and of the rules, regulations, and relevant orders of the Secretary of Labor.*
- (5) *The contractor will furnish all information and reports required by Executive Order 11246 of September 24, 1965, and by rules, regulations, and orders of the Secretary of Labor, or pursuant thereto, and will permit access to his books, records, and accounts by the administering agency and the Secretary of Labor for purposes of investigation to ascertain compliance with such rules, regulations, and orders.*
- (6) *In the event of the contractor's noncompliance with the nondiscrimination clauses of this contract or with any of the said rules, regulations, or orders, this contract may be cancelled, terminated or suspended in whole or in part and the contractor may be declared ineligible for further Government contracts or federally assisted construction contracts in accordance with procedures authorized in Executive Order 11246 of September 24, 1965, and such other sanctions may be imposed and remedies invoked as provided in Executive Order 11246 of September 24, 1965, or by rule, regulation, or order of the Secretary of Labor, or as otherwise provided by law.*

- (7) *The contractor will include the portion of the sentence immediately preceding paragraph (1) and the provisions of paragraphs (1) through (7) in every subcontract or purchase order unless exempted by rules, regulations, or orders of the Secretary of Labor issued pursuant to section 204 of Executive Order 11246 of September 24, 1965, so that such provisions will be binding upon each subcontractor or vendor. The contractor will take such action with respect to any subcontract or purchase order as the administering agency may direct as a means of enforcing such provisions, including sanctions for noncompliance: Provided, however, That in the event the contractor becomes involved in, or is threatened with, litigation with a subcontractor or vendor as a result of such direction by the administering agency the contractor may request the United States to enter into such litigation to protect the interests of the United States.*

The applicant further agrees that it will be bound by the above equal opportunity clause with respect to its own employment practices when it participates in federally assisted construction work: Provided, That if the applicant so participating is a State or local government, the above equal opportunity clause is not applicable to any agency, instrumentality or subdivision of such government which does not participate in work on or under the contract.

The applicant agrees that it will assist and cooperate actively with the administering agency and the Secretary of Labor in obtaining the compliance of contractors and subcontractors with the equal opportunity clause and the rules, regulations, and relevant orders of the Secretary of Labor, that it will furnish the administering agency and the Secretary of Labor such information as they may require for the supervision of such compliance, and that it will otherwise assist the administering agency in the discharge of the agency's primary responsibility for securing compliance.

The applicant further agrees that it will refrain from entering into any contract or contract modification subject to Executive Order 11246 of September 24, 1965, with a contractor debarred from, or who has not demonstrated eligibility for, Government contracts and federally assisted construction contracts pursuant to the Executive order and will carry out such sanctions and penalties for violation of the equal opportunity clause as may be imposed upon contractors and subcontractors by the administering agency or the Secretary of Labor pursuant to Part II, Subpart D of the Executive order. In addition, the applicant agrees that if it fails or refuses to comply with these undertakings, the administering agency may take any or all of the following actions: Cancel, terminate, or suspend in whole or in part this grant (contract, loan, insurance, guarantee); refrain from extending any further assistance to the applicant under the program with respect to which the failure or refund occurred until satisfactory assurance of future compliance has been received from such applicant; and refer the case to the Department of Justice for appropriate legal proceedings.

(c) Standard Federal Equal Employment Opportunity Construction Contract Specifications (Executive Order 11246)

1. *As used in these specifications:*

- a. *“Covered area” means the geographical area described in the solicitation from which this contract resulted;*
 - b. *“Director” means Director, Office of Federal Contract Compliance Programs, United States Department of Labor, or any person to whom the Director delegates authority;*
 - c. *“Employer identification number” means the Federal Social Security number used on the Employer’s Quarterly Federal Tax Return, U.S. Treasury Department Form 941.*
 - d. *“Minority” includes:*
 - (i) *Black (all persons having origins in any of the Black African racial groups not of Hispanic origin);*
 - (ii) *Hispanic (all persons of Mexican, Puerto Rican, Cuban, Central or South American or other Spanish Culture or origin, regardless of race);*
 - (iii) *Asian and Pacific Islander (all persons having origins in any of the original peoples of the Far East, Southeast Asia, the Indian Subcontinent, or the Pacific Islands); and*
 - (iv) *American Indian or Alaskan Native (all persons having origins in any of the original peoples of North America and maintaining identifiable tribal affiliations through membership and participation or community identification).*
2. *Whenever the Contractor, or any Subcontractor at any tier, subcontracts a portion of the work involving any construction trade, it shall physically include in each subcontract in excess of \$10,000 the provisions of these specifications and the Notice which contains the applicable goals for minority and female participation and which is set forth in the solicitations from which this contract resulted.*
 3. *If the Contractor is participating (pursuant to 41 CFR 60-4.5) in a Hometown Plan approved by the U.S. Department of Labor in the covered area either individually or through an association, its affirmative action obligations on all work in the Plan area (including goals and timetables) shall be in accordance with that Plan for those trades which have unions participating in the Plan. Contractors must be able to demonstrate their participation in and compliance with the provisions of any such Hometown Plan. Each Contractor or Subcontractor participating in an approved plan is individually required to comply with its obligations under the EEO clause,*

and to make a good faith effort to achieve each goal under the Plan in each trade in which it has employees. The overall good faith performance by other Contractors or Subcontractors toward a goal in an approved Plan does not excuse any covered Contractor's or Subcontractor's failure to take good faith efforts to achieve the Plan goals and timetables.

4. *The Contractor shall implement the specific affirmative action standards provided in Paragraphs 7 a through p of these specifications. The goals set forth in the solicitation from which this contract resulted are expressed as percentages of the total hours of employment and training of minority and female utilization the Contractor should reasonably be able to achieve in each construction trade in which it has employees in the covered area. Covered construction contractors performing construction work in geographical areas where they do not have a Federal or federally assisted construction contract shall apply the minority and female goals established for the geographical area where the work is being performed. Goals are published periodically in the FEDERAL REGISTER in notice form, and such notices may be obtained from any Office of Federal Contract Compliance Programs office or from Federal procurement contracting officers. The Contractor is expected to make substantially uniform progress in meeting its goals in each craft during the period specified.*
5. *Neither the provisions of any collective bargaining agreement, nor the failure by a union with whom the Contractor has a collective bargaining agreement, to refer either minorities or women shall excuse the Contractor's obligations under these specifications, Executive Order 11246, or the regulations promulgated pursuant thereto.*
6. *In order for the nonworking training hours of apprentices and trainees to be counted in meeting the goals, such apprentices and trainees must be employed by the Contractor during the training period, and the Contractor must have made a commitment to employ the apprentices and trainees at the completion of their training, subject to the availability of employment opportunities. Trainees must be trained pursuant to training programs approved by the U.S. Department of Labor.*
7. *The Contractor shall take specific affirmative actions to ensure equal employment opportunity. The evaluation of the Contractor's compliance with these specifications shall be based upon its effort to achieve maximum results from its actions. The Contractor shall document these efforts fully, and shall implement affirmative action steps at least as extensive as the following:*
 - a. *Ensure and maintain a working environment free of harassment, intimidation, and coercion at all sites, and in all facilities at which the Contractor's employees are assigned to work. The Contractor, where possible, will assign two or more women to each construction project. The*

Contractor shall specifically ensure that all foremen, superintendents, and other on-site supervisory personnel are aware of and carry out the Contractor's obligation to maintain such a working environment, with specific attention to minority or female individuals working at such sites or in such facilities.

- b. Establish and maintain a current list of minority and female recruitment sources, provide written notification to minority and female recruitment sources and to community organizations when the Contractor or its unions have employment opportunities available, and maintain a record of the organizations' responses.*
- c. Maintain a current file of the names, addresses, and telephone numbers of each minority and female off-the-street applicant and minority or female referral from a union, a recruitment source, or community organization and of what action was taken with respect to each such individual. If such individual was sent to the union hiring hall for referral and was not referred back to the Contractor by the union or, if referred, not employed by the Contractor, this shall be documented in the file with the reason therefor, along with whatever additional actions the Contractor may have taken.*
- d. Provide immediate written notification to the Director when the union or unions with which the Contractor has a collective bargaining agreement has not referred to the Contractor a minority person or woman sent by the Contractor, or when the Contractor has other information that the union referral process has impeded the Contractor's efforts to meet its obligations.*
- e. Develop on-the-job training opportunities and/or participate in training programs for the area which expressly include minorities and women, including upgrading programs and apprenticeship and trainee programs relevant to the Contractor's employment needs, especially those programs funded or approved by the Department of Labor. The Contractor shall provide notice of these programs to the source compiled under 7b above.*
- f. Disseminate the Contractor's EEO policy by providing notice of the policy to unions and training programs and requesting their cooperation in assisting the Contractor in meeting its EEO obligations; by including it in any policy manual and collective bargaining agreement; by publicizing it in the company newspaper, annual report, etc.; by specific review of the policy with all management personnel and with all minority and female employees at least once a year; and by posting the company EEO policy on bulletin boards accessible to all employees at each location where construction work is performed.*

- g. *Review, at least annually, the company's EEO policy and affirmative action obligations under these specifications with all employees having any responsibility for hiring, assignment, layoff, termination, or other employment decisions including specific review of these items with onsite supervisory personnel such as Superintendents, General Foremen, etc., prior to the initiation of construction work at any job site. A written record shall be made and maintained identifying the time and place of these meetings, persons attending, subject matter discussed, and disposition of the subject matter.*
- h. *Disseminate the Contractor's EEO policy externally by including it in any advertising in the news media, specifically including minority and female news media, and providing written notification to and discussing the Contractor's EEO policy with other Contractors and Subcontractors with whom the Contractor does or anticipates doing business.*
- i. *Direct its recruitment efforts, both oral and written, to minority, female, and community organizations, to schools with minority and female students and to minority and female recruitment and training organizations serving the Contractor's recruitment area and employment needs. Not later than one month prior to the date for the acceptance of applications for apprenticeship or other training by any recruitment source, the Contractor shall send written notification to organizations such as the above, describing the openings, screening procedures, and tests to be used in the selection process.*
- j. *Encourage present minority and female employees to recruit other minority persons and women and, where reasonable, provide after school, summer, and vacation employment to minority and female youth both on the site and in other areas of the Contractor's work force.*
- k. *Validate all tests and other selection requirements where there is an obligation to do so under 41 CFR Part 60-3.*
- l. *Conduct, at least annually, an inventory and evaluation at least of all minority and female personnel for promotional opportunities and encourage these employees to seek or to prepare for, through appropriate training, etc., such opportunities.*
- m. *Ensure that seniority practices, job classifications, work assignments, and other personnel practices, do not have discriminatory effect by continually monitoring all personnel and employment related activities to ensure that the EEO policy and the Contractor's obligations under these specifications are being carried out.*
- n. *Ensure that all facilities and company activities are nonsegregated except*

that separate or single-user toilet and necessary changing facilities shall be provided to assure privacy between the sexes.

- o. Document and maintain a record of all solicitations of offers for subcontracts from minority and female construction contractors and suppliers, including circulation of solicitations to minority and female contractor associations and other business associations.*
- p. Conduct a review, at least annually, of all supervisors' adherence to and performance under the Contractor's EEO policies and affirmative action obligations.*
- 8. Contractors are encouraged to participate in voluntary associations which assist in fulfilling one or more of their affirmative action obligations (7a through p). The efforts of a contractor association, joint contractor-union, contractor-community, or other similar group of which the Contractor is a member and participant, may be asserted as fulfilling any one or more of its obligations under 7a through p of these Specifications provided that the contractor actively participates in the group, makes every effort to assure that the group has a positive impact on the employment of minorities and women in the industry, ensures that the concrete benefits of the program are reflected in the Contractor's minority and female workforce participation, makes a good faith effort to meet its individual goals and timetables, and can provide access to documentation which demonstrates the effectiveness of actions taken on behalf of the Contractor. The obligation to comply, however, is the Contractor's and failure of such a group to fulfill an obligation shall not be a defense for the Contractor's noncompliance.*
- 9. A single goal for minorities and a separate single goal for women have been established. The Contractor, however, is required to provide equal employment opportunity and to take affirmative action for all minority groups, both male and female, and all women, both minority and non-minority. Consequently, the Contractor may be in violation of the Executive Order if a particular group is employed in a substantially disparate manner (for example, even though the Contractor has achieved its goals for women generally, the Contractor may be in violation of the Executive Order if a specific minority group of women is underutilized).*
- 10. The Contractor shall not use the goals and timetables or affirmative action standards to discriminate against any person because of race, color, religion, sex, or national origin.*
- 11. The Contractor shall not enter into any Subcontract with any person or firm debarred from Government contracts pursuant to Executive Order 11246.*
- 12. The Contractor shall carry out such sanctions and penalties for violation of*

these specifications and of the Equal Opportunity Clause, including suspension, termination, and cancellation of existing subcontracts as may be imposed or ordered pursuant to Executive Order 11246, as amended, and its implementing regulations, by the Office of Federal Contract Compliance Programs. Any Contractor who fails to carry out such sanctions and penalties shall be in violation of these specifications and Executive Order 11246, as amended.

- 13. The Contractor, in fulfilling its obligations under these specifications, shall implement specific affirmative action steps, at least as extensive as those standards prescribed in paragraph 7 of these specifications, so as to achieve maximum results from its efforts to ensure equal employment opportunity. If the Contractor fails to comply with the requirements of the Executive Order, the implementing regulations, or these specifications, the Director shall proceed in accordance with 41 CFR 60-4.8.*
- 14. The Contractor shall designate a responsible official to monitor all employment related activity to ensure that the company EEO policy is being carried out, to submit reports relating to the provisions hereof as may be required by the Government and to keep records. Records shall at least include for each employee the name, address, telephone numbers, construction trade, union affiliation if any, employee identification number when assigned, social security number, race, sex, status (e.g., mechanic, apprentice trainee, helper, or laborer), dates of changes in status, hours worked per week in the indicated trade, rate of pay, and locations at which the work was performed. Records shall be maintained in an easily understandable and retrievable form; however, to the degree that existing records satisfy this requirement, contractors shall not be required to maintain separate records.*
- 15. Nothing herein provided shall be construed as a limitation upon the application of other laws which establish different standards of compliance or upon the application of requirements for the hiring of local or other area residents (e.g., those under the Public Works Employment Act of 1977 and the Community Development Block Grant Program).*

100-C-151E TITLE VI ASSURANCES

(Revised 10-05-10)

During the performance of this contract, the contractor, for itself, its assignees and successors in interest (hereinafter referred to as the "contractor") agrees as follows:

- 1. Compliance with Regulations:** The contractor shall comply with the Regulations relative to nondiscrimination in Federally-assisted

programs of the Department of Transportation Title 49, Code of Federal Regulations, Part 21, as they may be amended from time to time, (hereinafter referred to as the Regulations), which are herein incorporated by reference and made a part of this contract.

2. **Nondiscrimination:** The contractor, with regard to the work performed by it during the contract, shall not discriminate on the grounds or race, color, sex, age, national origin, disability/handicap, or income status in the selection and retention of subcontractors, including procurements of materials and leases of equipment. The contractor shall not participate either directly or indirectly in the discrimination prohibited by section 21.5 of the Regulations, including employment practices when the contract covers a program set forth in Appendix B of the Regulations.
3. **Solicitations for Subcontracts, Including Procurements of Materials and Equipment:** In all solicitations either by competitive bidding or negotiation made by the contractor for work to be performed under a subcontract, including procurements of materials or leases of equipment, each potential subcontractor or supplier shall be notified by the contractor of the contractor's obligations under this contract and the Regulations relative to nondiscrimination on the grounds of race, color, sex, age, national origin, disability/handicap, or income status.
4. **Information and Reports:** The contractor shall provide all information and reports required by the Regulations, or directives issued pursuant thereto, and shall permit access to its books, records, accounts, other sources of information, and its facilities as may be determined by the Indiana Department of Transportation or the Federal Highway Administration to be pertinent to ascertain compliance with such Regulations, orders and instructions. Where any information required of a contractor is in the exclusive possession of another who fails or refuses to furnish this information, the contractor shall so certify to the Indiana Department of Transportation, or the Federal Highway Administration as appropriate, and shall set forth what efforts it has made to obtain the information.
5. **Sanctions for Noncompliance:** In the event of the contractor's noncompliance with the nondiscrimination provisions of this contract, the Indiana Department of Transportation shall impose such contract sanctions as it or the Federal Highway Administration may determine to be appropriate, including, but not limited to: (a) withholding of payments to the contractor under the contract until the contractor complies, and/or (b) cancellation, termination or suspension of the contract, in whole or in part.
6. **Incorporation of Provisions:** The contractor shall include the provisions of paragraphs (1) through (6) in every subcontract, including procurements of materials and leases of equipment, unless exempt by the Regulations, or directives issued pursuant thereto.

The contractor shall take such action with respect to any subcontract or procurement as the Indiana Department of Transportation or the Federal Highway Administration may direct as a means of enforcing such provisions including sanctions for non-compliance, provided, however, that, in the event a contractor becomes involved in, or is threatened with, litigation with a subcontractor or supplier as a result of such direction, the contractor may request the Indiana Department of Transportation to enter into such litigation to protect the interests of the Indiana Department of Transportation, and, in addition, the contractor may request the United States to enter into such litigation to protect the interests of the United States.

100-C-188 STANDARD SPECIFICATIONS

(Revised 05-23-13)

Wherever in the contract documents the 1999, 2006, 2008, 2010 or 2012 Standard Specifications are referenced, it shall be interpreted to mean the 2014 Standard Specifications.

100-C-209 SUBCONTRACT REPORT AND PAYMENTS REQUIREMENTS

(Adopted 04-15-14)

The Standard Specifications are revised as follows:

SECTION 108, AFTER LINE 28, INSERT AS FOLLOWS:

The Contractor shall submit payment records through the Department's Subcontractor Payment Tracking System (<http://itap.indot.in.gov>) of all payments made to subcontractors, including lessors and material suppliers. Reports shall be submitted no later than 10 days after the end of each month in which a subcontractor is paid for work on the contract. Reports shall include any release of retainage payments made to subcontractors.

SECTION 109, AFTER LINE 924, INSERT AS FOLLOWS:

Within 10 business days of receipt of payment for any such estimate, the Contractor shall make payment to all subcontractors, including lessors and material suppliers, for the value of their work performed and materials complete in place in accordance with this contract. Failure to comply with this clause shall constitute a material breach of the contract and may result in sanctions under the contract.

Any delay or postponement of payment among the parties may take place only for good cause, with the Department's written approval. The explanation from the Contractor shall be made in writing to the Department.

 100-C-214 CONSTRUCTION LETTING E-MAIL BOX

(Revised 04-23-08)

The Contractor has the option to submit certain contract bid documents, as defined in the proposal, either as original paper copies filed with the proposal or as electronic documents.

To submit electronic documents, the Contractor shall attach the documents to an e-mail sent to the following address:

constructionletting@indot.in.gov

To ensure that the electronic documents are placed in the correct contract folder with a date and time stamp and that they cannot be altered, the subject line of the e-mail shall contain the following information in the exact format shown:

CompanyNameDocumentTitleLettingDate-ContractNumber

The subject line shall contain no spaces, periods, commas, apostrophes or other punctuation marks other than the one hyphen indicated between CompanyNameDocumentTitleLettingDate and ContractNumber.

LettingDate shall be in the format MMDDYY.

ContractNumber shall be in the format AA#####Z, where AA is the 1 or 2 letter prefix, ##### is the 5 digit number and Z is the 1 letter suffix.

The following is an example of the subject line for the Jones Construction Co., Inc., submitting a drug testing plan for contract IR-30999-A for a March 15, 2008 letting:

JonesConstructionCoIncDrugPlan031508-IR30999A

Documents must be time stamped by the INDOT e-mail box prior to the time stated in the advertisement.

108-C-585 WORKING RESTRICTIONS DURING CERTAIN HOLIDAY PERIODS

(Revised 05-23-13)

The Standard Specifications are revised as follows:

SECTION 108, AFTER LINE 395, DELETE AND INSERT AS FOLLOWS:

Contractors will not be permitted to work during the following holiday periods unless prior written approval is received from the Engineer. All deliveries and traffic coming from suppliers shall cease during the Department-ordered suspensions of work listed below. No time extensions to closure periods, intermediate completion dates, or contract completion dates will be granted for suspending work during these holiday periods.

- (a) *New Year's Day. If New Year's Day falls on a Sunday, work shall be suspended from noon December 31 until sunrise January 3. If New Year's Day falls on a Monday through Saturday, work shall be suspended from noon December 31 until sunrise January 2.*
- (b) *Good Friday. Work shall be suspended from noon on Good Friday until sunrise Monday.*
- (c) *Memorial Day. Work shall be suspended from noon the Friday before Memorial Day until sunrise Tuesday, the day after Memorial Day.*
- (d) *Independence Day. If Independence Day falls on a:*
- Sunday - Work shall be suspended from noon Friday, July 2, until sunrise Tuesday, July 6.*
- Monday - Work shall be suspended from noon Friday, July 1, until sunrise Tuesday, July 5.*
- Tuesday - Work shall be suspended from noon Friday, June 30, until sunrise Wednesday, July 5.*
- Wednesday - Work shall be suspended from sunset on Tuesday, July 3, until sunrise Thursday, July 5.*
- Thursday - Work shall be suspended from noon Wednesday, July 3, until sunrise Monday, July 8.*
- Friday - Work shall be suspended from noon Thursday, July 3, until sunrise Monday, July 7.*
- Saturday - Work shall be suspended from noon Thursday, July 2, until sunrise Monday, July 6.*
- (e) *Labor Day. Work shall be suspended from noon the Friday before Labor Day until sunrise Tuesday, the day after Labor Day.*
- (f) *Thanksgiving Day. Work shall be suspended from noon the Wednesday before Thanksgiving Day until sunrise the Monday after Thanksgiving Day.*
- (g) *Christmas Day. Work shall be suspended from noon December 24 until sunrise December 27.*

The Department may order the suspension of work, either wholly or in part, for a period of time for certain holidays *not already specified herein*. For such orders, ~~if the contract suspension is not stated in the contract documents,~~ the contract completion time will be adjusted as follows:

109-C-219 PG ASPHALT BINDER MATERIAL COST ADJUSTMENTS

(Revised 05-23-13)

The Standard Specifications are revised as follows:

SECTION 109, AFTER LINE 902, INSERT AS FOLLOWS:

109.05.3 PG Asphalt Binder Material Cost Adjustments

The Contractor shall elect at the time the bid proposal is submitted, in a manner determined by the Department, whether or not to enact PG asphalt binder material cost adjustments. If the Contractor elects not to enact such adjustments, there will be no adjusted payment made to the Contractor for changes in the cost of PG asphalt binder materials used on the project and the provisions of this specification will not be applied to the contract. PG asphalt binder material cost adjustments will not be added to the contract at any time after the Contractor has elected not to enact such adjustments with submittal of the bid proposal. PG asphalt binder material cost adjustments will not be applied to alternate bid pavement items, but may be applied to the common items on contracts containing alternate bid pavement items.

When the Contractor elects to enact PG asphalt binder material cost adjustments at the time the bid proposal is submitted, the Department will adjust payment to the Contractor due to an increase or decrease in the cost of PG asphalt binder material used on the project to produce HMA mixtures that are paid in accordance with 304, 401, 402, 410, 414, 610 or 718. Payment will be adjusted when an increase or decrease in the PG asphalt binder index for the contract is greater than or equal to 10.01%. Payment will only be adjusted when the total original or revised quantity of at least one HMA pay item exceeds 2,000 tons.

For contracts without any original HMA pay item quantity equal to or greater than 2,000 tons, adjusted payment will not be made until the revised quantity of at least one HMA pay item meets the quantity criteria. No adjusted payment will be made on any quantity of HMA items placed prior to when the 2,000 ton criteria has been met.

The Department will determine a PG asphalt binder index from one or more commercial services that provide regional indices. The PG asphalt binder index will be maintained by the Office of Materials Management and posted on the Department's website. The posting will include an explanation of how the index is determined. A monthly payment adjustment will be calculated for each HMA pay item placed on the contract during that month. The total PG asphalt binder adjustment applied to the contract each month will be the sum of the calculations for each HMA pay item. The payment adjustment for each HMA pay item will be calculated as follows:

For a price increase:

$$MPA = (Q \times Pb) / 100 \times LI \times [(BI-LI) / LI - 0.10]$$

For a price decrease:

$$MPA = (Q \times Pb) / 100 \times LI \times [(BI-LI) / LI + 0.10]$$

Where:

MPA = Mixture Payment Adjustment, in dollars, calculated to the nearest 0.01 dollar for each HMA pay item.

Q = Quantity of a HMA pay item placed, in tons, entered to the actual 0.01 unit placed. The quantity will be calculated prior to calculation of any other quantity adjustment.

Pb = Percent of virgin asphalt binder from the DMF, in the adjustment period, or JMF for the HMA mixture, entered to the nearest 0.1.

BI = PG asphalt binder index for the month the HMA pay item is placed, reported to the nearest whole dollar.

LI = PG asphalt binder index for the contract. The LI for all original contract HMA pay items equals the BI for the month immediately prior to the month of letting for the contract. The LI for any HMA extra work pay item will be the BI for the month the unit price for the pay item is submitted by the Contractor.

The calculation of (BI-LI)/LI will be rounded to the nearest 0.001. Payment will only be adjusted when the absolute value of (BI-LI)/LI is equal to or greater than 0.101.

If HMA pay items are placed beyond the specified contract completion date for the contract, the Department will calculate pay adjustments on the BI for the month of the specified completion date or the month of placement, whichever result is less.

The unit price of PG asphalt binder payment adjustment will be \$1.00 and the pay quantities will be in units of dollars.

Payment will be made under:

Pay Item	Pay Unit Symbol
Payment Adjustment, PG Asphalt Binder	DOL

203-R-550 APPROVAL OF BORROW AND DISPOSAL SITES

(Revised 05-23-13)

The Standard Specifications are revised as follows:

SECTION 201, BEGIN LINE 3, INSERT AS FOLLOWS:

201.01 Description

This work shall consist of clearing, grubbing, removing, and disposing of all vegetation and debris, except such objects as are designated to remain or are to be removed in accordance with other sections of these specifications, within the construction limits shown on the plans. If no construction limits are shown, the right-of-way and easement areas will be the construction limits. This work shall include the preservation from injury or defacement of all vegetation and objects designated to remain. *Disposal of material shall be in accordance with 203.08.*

SECTION 201, BEGIN LINE 43, DELETE AND INSERT AS FOLLOWS:

Unless burned in accordance with the requirements herein, perishable materials and debris shall be removed from the right-of-way and disposed of ~~at locations off the construction site and outside the limits of view from the traveled roadway in accordance with 203.08. If permitted, sod. Sod~~ may be disposed of within the right-of-way, but outside the construction limits, ~~if allowed. Written permission shall be obtained from the property owner on whose property the materials and debris are to be placed. All necessary arrangements shall be made with the owner for obtaining suitable disposal locations. The cost involved shall be included in the contract price of pay items.~~

SECTION 202, BEGIN LINE 13, DELETE AND INSERT AS FOLLOWS:

202.02 General Requirements

All buildings and foundations in accordance with 202.06, structures, fences, tanks, and other obstructions, any portions of which are on the right-of-way shall be razed, removed, and disposed of, except utilities and those features for which other provisions have been made for removal. Designated salvageable material shall be removed without unnecessary damage in sections or pieces which may be transported readily and shall be stored at specified places within the project limits or as otherwise designated. ~~Unless otherwise specified and e~~Except for regulated materials, which ~~are defined in~~ shall be disposed of in accordance with 104.06, and bridge painting debris which is subject to 619, non-salvageable material shall be disposed of in accordance with ~~State, Federal, and local regulations~~203.08. ~~Unregulated material that may be disposed of on private property, other than approved landfill sites, shall only be done with written approval of the Engineer and the property owner with appropriate permits and shall be outside the limits of view from the traveled roadway. Copies of all agreements with property owners shall be furnished.~~ Unsuitable material shall be removed from cisterns, septic tanks, other tanks, basements, and cavities. The disposition of this material shall be in accordance with all applicable and current State, Federal, and Local Regulations.

SECTION 203, BEGIN LINE 51, DELETE AND INSERT AS FOLLOWS:

203.08 Borrow or Disposal

Borrow shall consist of approved material required for the construction of embankments or for other portions of the work and shall be obtained from approved locations and sources outside the right-of-way. Borrow material shall be free of substances that will form deleterious deposits, or produce toxic concentrations or combinations that may be harmful to human, animal, plant or aquatic life, or otherwise impair the designated uses of ~~the a~~ stream or area. Unless otherwise designated in the contract, arrangements shall be made for obtaining borrow. Borrow, as designated herein, shall not include material excavated beyond the right-of-way limits at intersecting public roads, private and commercial drive approaches, ~~or~~ and material furnished as B borrow.

Disposal of waste material, other than regulated material, from within the right-of-way shall only be allowed at approved locations either within or outside the right-of-way. Disposal of regulated material shall be in accordance with 104.06.

~~Proposed borrow sites and proposed disposal sites for excavated material shall be identified before such material is excavated or disposed of within or outside the right of way.~~

Except where a ~~permitted or~~ licensed commercial site or a permitted site is utilized for borrow or disposal, the Contractor shall obtain all permits required by local, State and Federal laws prior to the start of any operations at the site.

Licensed commercial sites and permitted sites are defined as follows:

- (a) A licensed commercial site is a solid waste facility with a current IDEM operation number.*
- (b) A permitted site is a location that is operated under permits required by local, state and federal laws for the activities proposed by the Contractor. A permitted site shall also have documentation that a wetlands delineation and an archaeological survey have been performed by qualified professionals.*

For proposed borrow or disposal sites other than licensed commercial or permitted sites, an inspection of areas outside the construction limits shall be conducted by a qualified wetland professional approved by the Department to determine if wetlands are present on the site. An approved wetland professional shall be prequalified with the Department to perform environmental services work type 5.4 Ecological Surveys or shall be certified by the Society of Wetland Scientists as a wetland professional-in-training or professional wetland scientist. A list of approved wetland professionals is maintained on the Department's website. ~~This~~ The wetlands inspection shall be in accordance with the Federal Manual for Identifying and Delineating Jurisdictional Wetlands. The inspection shall also determine if isolated wetlands as defined by the IDEM are present. ~~The Contractor shall submit a document, signed by the wetland~~

~~professional, verifying that the site has been inspected for the presence of wetlands in accordance with the federal manual and for isolated wetlands and, if any are present, specifying the area to be demarcated as jurisdictional waters and/or wetland. The Contractor shall demarcate in a method approved by the Engineer the boundary of all wetlands identified within the proposed borrow or disposal site. Once the area to be used for borrow or for disposal of excavated material has been shown not to contain jurisdictional or isolated wetlands, the boundary of the area cleared shall be demarcated. The methods of demarcation shall be as approved by the Engineer.~~

For proposed borrow or disposal sites other than licensed commercial or permitted sites, a qualified archaeologist shall perform a record check and field survey to determine if any significant archaeological sites exist within the proposed site. The Indiana Department of Natural Resources Division of Historic Preservation and Archeology maintains a roster of qualified archeological consultants. If any archaeological sites are identified, the archaeologist shall establish the limits of the site along with a reasonable border. The Contractor shall demarcate in a method approved by the Engineer the border of all archeological sites identified within the proposed borrow or disposal site.

Identified archeological sites shall not be disturbed unless the site is cleared by established procedures and written authorization to enter the site has been obtained by the Contractor.

~~The Department maintains a list of professional consultants who are prequalified to perform various types of work. A qualified wetland professional shall be a professional consultant who is prequalified with the Department to perform Environmental Services work type 5.4 Ecological Surveys, or is certified by the Society of Wetland Scientists, SWS, as a wetland professional in training or professional wetland scientist.~~

~~Previously approved sites may be utilized for borrow or disposal operations if the Contractor furnishes a valid permit or document signed by a wetland professional prior to utilizing the site.~~

Borrow and disposal sites shall be approved by the Engineer prior to the start of any earth disturbing operations at the site. A request for approval of a borrow or disposal site shall be submitted to the Engineer a minimum of 14 days prior to the Contractor's planned start of operations at the site. All requests for approval of a borrow or disposal site shall include a description of the Contractor's planned operations at the site. In the case of disposal sites, the description shall include a listing of the types of material to be disposed of at the site.

A request for approval of a licensed commercial site shall include the following:

- (a) The name and address of the facility.*
- (b) The IDEM operating number.*
- (c) The expiration date of the IDEM operating permit.*

A request for approval of a permitted site shall include the following:

- (a) Name of the site owner.*
- (b) Address of the site.*
- (c) A list of the permits, permit numbers and permit expiration dates for all permits under which the site operates.*
- (d) Documentation that a wetlands delineation and an archaeological survey have been performed by qualified professionals.*

A request for approval of a site, other than a licensed commercial or permitted site, shall include the following:

- (a) Name of the property owner.*
- (b) Address or location of the site.*
- (c) A copy of a right-of-entry obtained from the property owner. Rights-of-entry shall include rights for access by Department personnel to the site for the purposes of monitoring, measurement and sampling.*
- (d) A site plan showing the site location, site dimensions, adjacent property and right-of-way lines, all demarcated jurisdictional wetlands or isolated wetlands, all demarcated archeological sites, existing and proposed finished contours and proposed finished slope grades.*
- (e) A site operations plan detailing the operations proposed for the site, what equipment will be utilized, how the site will be accessed and any other information relevant to the operation of the site.*
- (f) A copy of the Rule 5 Notice of Intent, if required under 327 IAC 15-5.*
- (g) An erosion control plan for the site including the types of erosion control measures to be incorporated and the sequencing of the measures in respect to the operations plan for the site.*
- (h) Documentation signed by a wetlands professional verifying that the site has been inspected for the presence of both wetlands and isolated wetlands and, if any are present, specifying the area to be demarcated as jurisdictional or isolated wetlands.*
- (i) Documentation of the archeological record check and field survey signed by a qualified archeologist including the limits and border of any archeological site discovered.*
- (j) Copies of all other permits obtained by the Contractor to perform operations at the site.*

The Contractor shall provide the Engineer a minimum of 14 days notice prior to opening borrow areas for the purpose of obtaining original cross section elevations and measurements and to sample the borrow material prior to use.

The Contractor shall install temporary erosion and sediment control measures at borrow or disposal sites other than licensed commercial and permitted sites prior to the start of any earth disturbing activity. ~~If the Contractor elects to use the site, all required permits shall be obtained.~~ The Contractor shall develop and construct all mitigation measures necessary to and fulfill all the requirements detailed by such of all permits obtained by the Contractor for operation of a borrow or disposal site. ~~The Contractor shall also obtain written permission from the land owner for Department personnel to access the site for monitoring.~~

No excavation shall occur or no material shall be disposed of ~~beyond~~ within the boundaries of the demarcated wetlands and archeological areas unless the operations are in compliance with all required permits and these specifications.

No extension of completion time will be granted due to any delays by the Contractor in securing approval of borrow or disposal sites.

~~Before borrow or disposal operations are begun, the Contractor shall submit operation plans for approval. Such plans shall include the following:~~

- ~~(a) a detailed sketch showing the limits relative to property and right-of-way lines;~~*
- ~~(b) the grade of all slopes;~~*
- ~~(c) an erosion control plan in accordance with the requirements of 327 IAC 15-5;~~*
- ~~(d) the encasement, finished grading, and seeding procedures; and~~*
- ~~(e) archaeological clearance.~~*

~~Notice shall be given in advance of opening borrow areas so that cross section elevations and measurements of the ground surface after stripping may be taken and the borrow material may be tested before being used.~~

~~Except when a commercial source is utilized, a qualified archaeologist shall perform a record check and field survey of borrow or disposal limits to determine if any significant archaeological sites are within the limits. Results of the record check and survey shall be furnished in writing prior to the excavation of any material. If any archaeological sites are identified, the archaeologist shall establish the limits of the site along with a reasonable border. The site shall not be disturbed unless the archaeological site is cleared by established procedures and written authorization to enter the site has been issued. No extension of completion time will be granted due to any delays in securing approval of a borrow or disposal site.~~

Approval of a proposed borrow or disposal site by the Engineer, whether the proposed site is commercial, permitted, or otherwise, shall not relieve the Contractor of its responsibility to utilize an appropriate site and to comply with all Local, State and Federal laws and regulations.

SECTION 203, BEGIN LINE 294, DELETE AND INSERT AS FOLLOWS:

203.10 Disposal of Excavated Material Except Waterway and Peat Excavation

Excavation material shall be used for the construction of embankments, shoulders, special fill, or other places as may be specified or directed, depending on the nature of the material. Excavated material that is suitable for embankment construction, that is not required for maintenance of traffic, shall be placed in the embankment before placing any borrow material, unless otherwise authorized in writing.

If more material is excavated from within required cut slopelines than is needed to construct embankments or special fills, the excess may be used to widen embankments, flatten fill slopes, or be used otherwise as directed. All excess excavated material that cannot be used constructively within the project limits shall be disposed of off the right-of-way in accordance with ~~201.03 and~~ 203.08.

Excavation obtained from the right-of-way and planned to be used in fills may be wasted and replaced with borrow with no additional payment only after written permission is obtained. All required samples of the borrow or the excavation materials involved shall be furnished with no additional payment.

203.11 Disposal of Waterway Excavation

Unless otherwise provided, material resulting from waterway excavation shall be used ~~to fill old channels and~~, if suitable, in embankment, special fill, and approach embankments, or any combination of these, as specified or directed.

~~A~~ Any portion of waterway excavation *material* which is unsuitable for the above uses, a *any* portion which is suitable but is in excess of that required for such uses, or ~~if~~ *when* locations for such ~~disposal uses~~ are not available, the ~~disposal material~~ shall be *disposed of* in accordance with ~~201.03~~ 203.08.

203.12 Disposal of Peat

All material removed as peat excavation, removed or displaced by machine operation, or displaced by the advancing backfilling material shall be ~~uniformly spread between the toes of fill slopes and the swamp ditches or beyond, or otherwise~~ disposed of in accordance with 203.08.

306-R-613 MILLING

(Adopted 11-22-13)

The Standard Specifications are revised as follows:

SECTION 306, BEGIN LINE 1, DELETE AND INSERT AS FOLLOWS:

SECTION 306 – MILLING**306.01 Description**

This work shall consist of the milling of asphalt and concrete pavements and the disposal of milled materials in accordance with 105.03.

CONSTRUCTION REQUIREMENTS**306.02 General**

Milling operations shall be described in the QCP in accordance with ITM 803. Where the milling operation in a partial-day closure results in a longitudinal vertical or near vertical face exceeding 2 in. in height, the adjacent lane shall be milled during the same day, the milled lane resurfaced during the same day, or the vertical face tapered at a 45° angle or flatter. Where located within 3 in. of a curb, surface material that cannot be removed by the cold-milling machine shall be removed by other approved methods.

Transverse milled vertical faces greater than 1 in. that are exposed to traffic shall be transitioned in an approved manner.

Castings located in milling areas that are not to be adjusted may remain in place during the milling, or may be removed and replaced at the Contractor's option.

Localized weak areas uncovered by the milling process shall be patched in accordance with 304 or 305.

The milled material shall become the property of the Contractor, unless otherwise specified.

The roadway shall be cleaned before opening to traffic.

306.03 Equipment

Equipment for milling shall be in accordance with the following.

(a) Roadway Milling Machine

A milling machine shall be a power operated cold-milling machine, equipped with automatic control devices to establish profile grades by referencing from either the existing pavement or from independent grade control. The equipment shall have a positive means of controlling cross slope elevations, have an effective means for removing excess material from the surface, preventing airborne dust escaping from the operation, and producing a finished surface that provides a good bond to the new overlay.

Sufficient cutting teeth shall be on the *coarse milling or fine milling* cutting drum to produce cuttings such that 90% of the conglomerate particles pass a 2 in. sieve. *A coarse milling cutting drum shall have 5/8 in. spacing between the cutting teeth and be capable of producing a surface macrotexture ratio in accordance with ITM 812 equal to or greater than 1.8. A fine milling cutting drum shall have 5/16 in. or 3/8 in. spacing between the cutting teeth and be capable of producing a surface macrotexture ratio in accordance with ITM 812 equal to or greater than 5.0.*

(b) Power Saw

Sawing equipment shall be capable of maintaining the specified alignment and depth of cut without damaging the pavement.

(c) Rotary Power Broom

A motorized, pneumatic tired unit with rotary bristle broom head.

(d) Straightedge**1. Straightedge – 16 ft**

A 16 ft straightedge shall be a rigid beam mounted on two solid wheels on axles 16 ft apart. The straightedge has a mounted push bar to facilitate propelling the device along or across the pavement. Tolerance points are located at the 1/4, 1/2, and 3/4 points and may be composed of threaded bolts capable of being adjusted to the tolerance required.

2. Straightedge – 10 ft

A 10 ft straightedge is the same as a 16 ft straightedge except that the wheels are mounted 10 ft apart. A handheld rigid beam may be substituted.

306.04 Asphalt or PCCP Scarification Milling and Profile Preparation

~~Asphalt scarification and profile preparation shall consist of preparing a base for resurfacing by removing existing asphalt material. The entire existing asphalt surface shall be roughened by the operations. The existing pavement shall be milled to the cross slope as shown on the plans, and~~ Scarification milling shall consist of preparing a base for resurfacing by roughening the entire existing asphalt or PCCP surface. The milled pavement profile shall have a surface finish that does not vary longitudinally more than 1/4 in. from a 16 ft straightedge or as described in the QCP in accordance with 401.02. ~~The milled surface shall have macrotexture equal to or greater than 2.2 for single course overlays and 1.8 for multiple course overlays in accordance with ITM 812.~~

A fine milling cutting drum in accordance with 306.03(a) shall be used when a single course overlay is specified with a lay rate as shown on the plans less than 165 lb/sq yd and the maximum scarification mill cut depth is expected to be less than 3/4 in. for asphalt or PCCP, otherwise, a coarse milling cutting drum in accordance with 306.03(a) shall be used.

The scarified milled surface shall have a macrotexture ratio in accordance with ITM 812 as follows:

- (a) equal to or greater than 5.0 when using a fine milling cutting drum for a single course overlay, or*
- (b) equal to or greater than 2.2 for a single course overlay, or*
- (c) equal to or greater than 1.8 for multiple course overlays.*

Frequency of macrotexture testing shall be a minimum of once per day and shall be described in the QCP. The cross-slope shall not vary more than 1/8 in. when measured with a 10 ft straightedge.

Milled ~~mainline~~ *traveled* way-areas left open to traffic for longer than five work days will be assessed \$1,600.00 per day per lane mile, or portion thereof, as liquidated damages, not as a penalty, but as damages sustained for each work day that the milled area remains open to traffic.

Milled non-~~mainline~~ *traveled* way areas such as auxiliary lanes *and shoulders* left open to traffic for longer than 10 work days will be assessed \$800.00 per day per lane mile, or portion thereof, as liquidated damages, not as a penalty, but as damages sustained for each work day that the milled area remains open to traffic.

306.05 Asphalt or PCCP Profile Milling to Correct Cross-Slope

Profile milling shall consist of preparing a base for resurfacing by removing the existing asphalt or PCCP material to the specified cross-slope as shown on the plans. The milled pavement profile shall have a surface finish that does not vary longitudinally more than 1/4 in. from a 16 ft straightedge or as described in the QCP in accordance with 401.02.

A fine milling cutting drum in accordance with 306.03(a) shall be used when a single course overlay is specified with a lay rate as shown on the plans less than 165 lb/sq yd and the maximum profile mill cut depth is expected to be less than or equal to 1 1/2 in. for asphalt or 3/4 in. for PCCP, otherwise, a coarse milling cutting drum in accordance with 306.03(a) shall be used.

The profile milled surface shall have a macrotexture ratio in accordance with ITM 812 as follows:

- (a) equal to or greater than 5.0 when using a fine milling cutting drum for a single course overlay, or*
- (b) equal to or greater than 2.2 for a single course overlay, or*
- (c) equal to or greater than 1.8 for multiple course overlays.*

Frequency of macrotexture testing shall be a minimum of once per day and shall be described in the QCP. The cross-slope shall not vary more than 1/8 in. when measured with a 10 ft straightedge.

Milled traveled way areas left open to traffic for longer than five work days will be assessed \$1,600.00 per day per lane mile, or portion thereof, as liquidated damages, not as a penalty, but as damages sustained for each work day that the milled area remains open to traffic.

Milled non-traveled way areas such as auxiliary lanes and shoulders left open to traffic for longer than 10 work days will be assessed \$800.00 per day per lane mile, or portion thereof, as liquidated damages, not as a penalty, but as damages sustained for each work day that the milled area remains open to traffic.

306.04.106 Approach Milling

Approach milling shall consist of milling the surface and cutting a wedge at the driveways, commercial or public road approaches. The existing approach shall be milled a minimum depth of no less than 1/4 in. to accommodate the approach pavement. The approach milling shall be completed to provide a smooth transition from the ~~mainline~~-traveled way pavement to the termini of the approach. The existing approach pavement shall be cut to provide a vertical face of 1 1/2 in. for the termini of surface.

Mailbox approaches to be resurfaced shall be milled to maintain the ~~mainline~~traveled way profile and cross-slope.

Automatic control devices will not be required on surface milling equipment used for approach milling. Milling shall not damage any pavement that is to remain in place.

Approach milling shall not be performed at driveways unless it is required to meet a paved surface that continues beyond the construction limit. If the driveway is other than HMA or PCC beyond the construction limits, the approach milling is not required.

The transverse vertical cut face for commercial or public road approaches shall be transitioned at a rate of 24:1 or as approved.

306.0507 Asphalt or PCCP Milling to a Specified Average Depth

~~Asphalt m~~Milling shall consist of preparing a base for resurfacing by removing the existing asphalt material *or PCCP* ~~at~~*to* the specified average depth *as shown on the plans*. The existing milled pavement shall be milled to the cross-slope as shown on the plans, and shall have a surface finish that does not vary longitudinally more than 1/4 in. from a 16 ft straightedge or as described in the QCP in accordance with 401.02. ~~The milled surface shall have macrotexture equal to or greater than 2.2 for single course overlays and 1.8 for multiple course overlays in accordance with ITM 812.~~

A fine milling cutting drum in accordance with 306.03(a) shall be used when a single course overlay is specified with a lay rate as shown on the plans less than 165 lb/sq yd and the average mill cut depth is less than or equal to 1 1/2 in. for asphalt or 3/4 in. for PCCP, otherwise, a coarse milling cutting drum in accordance with 306.03(a) shall be used.

The milled surface shall have a macrotexture ratio in accordance with ITM 812 as follows:

- (a) equal to or greater than 5.0 when using a fine milling cutting drum for a single course overlay, or*
- (b) equal to or greater than 2.2 for a single course overlay, or*
- (c) equal to or greater than 1.8 for multiple course overlays.*

Frequency of macrotexture testing shall be a minimum of once per day and shall be described in the QCP. The cross-slope shall not vary more than 1/8 in. when measured with a 10 ft straightedge.

If shoulders or turn lanes are not milled and the overlay material is not placed in the milled areas within the same day, drainage slots shall be provided to eliminate ponding of water.

Milled ~~mainline~~*traveled* way areas left open to traffic for longer than five work days will be assessed \$1,600.00 per day per lane mile, or portion thereof, as liquidated damages, not as a penalty, but as damages sustained for each work day that the milled area remains open to traffic.

Milled non-~~mainline~~*traveled* way areas such as auxiliary lanes *and shoulders* left open to traffic for longer than 10 work days will be assessed \$800.00 per day per lane mile, or portion thereof, as liquidated damages, not as a penalty, but as damages sustained for each work day that the milled area remains open to traffic.

The transverse vertical cut face shall be transitioned by HMA, CMA or prefabricated materials at a rate of 24:1 or as approved.

306.0608 Asphalt Overlay Removal

Asphalt removal shall consist of complete removal of *an asphalt overlay* by milling from a portland cement concrete or brick base and the satisfactory disposal of the milled materials. Minor amounts of asphalt pavement material bonded to a concrete base at joints or cracks may remain in place. If this material becomes displaced during subsequent operations it shall be removed. Minor amounts of asphalt pavement material bonded to a brick base may remain in place. Removal of minor areas of portland cement concrete or brick base during the milling operations is acceptable.

Milled areas shall be cleaned prior to reopening to traffic or before continuing construction operations.

The transverse vertical cut face shall be transitioned by HMA, CMA or prefabricated materials at a rate of 24:1 or as approved.

~~306.07 PCCP Milling~~

~~PCCP milling shall consist of preparing a base for resurfacing by removing the existing PCCP material at a specified average depth. The existing pavement shall be milled to the cross-slope as specified in the plans, and shall have a surface finish that does not vary longitudinally more than 1/4 in. from a 16 ft straightedge or as described in the QCP in accordance with 401.02. The milled surface shall have macrotexture equal to or greater than 1.8 in accordance with ITM 812. Frequency of macrotexture testing shall be a minimum of once per day and shall be described in the QCP. The cross slope shall not vary more than 1/8 in. when measured with a 10 ft straightedge or as directed by the Engineer.~~

~~A milled surface shall not be left open to traffic for longer than 14 calendar days. If the milled surface is not overlaid after 14 calendar days, \$1,600.00 per day per lane mile, or portion thereof, will be assessed as liquidated damages, not as a penalty, but as damages sustained for each calendar day that the milled area remains left open to traffic.~~

~~Milled non-mainline areas such as auxiliary lanes left open to traffic for longer than 10 work days will be assessed \$100.00 per day per transition as liquidated damages, not as a penalty, but as damages sustained for each work day that the milled area remains open to traffic.~~

~~The transverse vertical cut face shall be transitioned by HMA, CMA or prefabricated materials at a rate of 24:1 or as approved.~~

306.0809 Transition Milling

Transition milling shall consist of cutting a wedge at the beginning and ending of projects, and paving exceptions. The existing pavement shall be cut to provide a nearly vertical face of 1 1/2 in. for the termini of each overlay lift of base, intermediate, and surface. The existing pavement shall be milled at a rate of 720:1 or as directed to achieve the specified cut where the pavement transition overlay lifts differ from cut depth. The transverse vertical cut face shall be transitioned by HMA, CMA or prefabricated materials at a rate of 24:1 or as approved.

400-R-610 PROVISIONS FOR HMA MIXTURES

(Adopted 06-20-13)

The Standard Specifications are revised as follows:

SECTION 401, BEGIN LINE 68, DELETE AND INSERT AS FOLLOWS:

Dense Graded, Mixture Designation – Control Point (Percent Passing)					
	25.0 mm	19.0 mm	12.5 mm	9.5 mm	4.75 mm**
Sieve Size					
50.0 mm					
37.5 mm	100.0				
25.0 mm	90.0 - 100.0	100.0			
19.0 mm	< 90.0	90.0 - 100.0	100.0		
12.5 mm		< 90.0	90.0 - 100.0	100.0	100.0
9.5 mm			< 90.0	90.0 - 100.0	95.0 - 100.0
4.75 mm				< 90.0	90.0 - 100.0
2.36 mm	19.0 - 45.0	23.0 - 49.0	28.0 - 58.0	32.0 - 67.0*	
1.18 mm					30.0 - 60.0 55.0
600 µm					
300 µm					
75 µm	1.0 - 7.0	2.0 - 8.0	2.0 - 10.0	2.0 - 10.0	6.0 - 12.0 3.0 - 8.0
* The mix design gradation shall be less than or equal to the PCS control point for 9.5 mm category 3, 4 and 5 surface mixtures.					
** The total blended aggregate gradation for the 4.75 mm mixture shall have a fineness modulus greater than or equal to 3.30 as determined in accordance with AASHTO T 27.					

PCS Control Point for Mixture Designation (Percent Passing)					
Mixture Designation	25.0 mm	19.0 mm	12.5 mm	9.5 mm	4.75 mm
Primary Control Sieve	4.75 mm	4.75 mm	2.36 mm	2.36 mm	NA
PCS Control Point	40	47	39	47	NA

Open Graded, Mixture Designation – Control Point (Percent Passing)			
	OG9.5	OG19.0	OG25.0
Sieve Size			
37.5 mm			100.0
25.0 mm		100.0	70.0 – 98.0
19.0 mm		70.0 – 98.0	50.0 – 85.0
12.5 mm	100.0	40.0 – 68.0	28.0 – 62.0
9.5 mm	75.0-100.0	20.0 – 52.0	15.0 – 50.0
4.75 mm	10.0-35.0	10.0 – 30.0	6.0 – 30.0
2.36 mm	0.0-15.0	7.0 – 23.0	7.0 – 23.0
1.18 mm		2.0 – 18.0	2.0 – 18.0
600 µm		1.0 – 13.0	1.0 – 13.0
300 µm		0.0 – 10.0	0.0 – 10.0
150 µm		0.0 – 9.0	0.0 – 9.0
75 µm	0-6.0	0.0 – 8.0	0.0 – 8.0
% of Binder	> 3.0	> 3.0	> 3.0

Dust/Calculated Effective Binder Ratio shall be taken from 0.6 to 1.2, when the aggregate gradation passes above the primary control sieve, PCS, control point and 0.8 to 1.6 when the aggregate gradation is less than or equal to the PCS. The Dust/Calculated Effective Binder Ratio for 4.75 mm mixtures shall be ~~0.9~~0.8 to 2.0.

The optimum binder content shall produce the following air voids at N_{des} :

Air Voids at Optimum Binder Content								
	Dense Graded					Open Graded		
Mixture Designation	25.0 mm	19.0 mm	12.5 mm	9.5 mm	4.75 mm	25.0 mm	19.0 mm	9.5 mm
Air Voids	4.0%	4.0%	4.0%	4.0%	5.0%	15.0% - 20.0%		10.0% - 15.0%

~~The optimum binder content for dense graded mixtures shall produce 4.0% air voids at N_{des} and for open graded mixtures shall produce 15.0% - 20.0% air voids at N_{des} .~~ The design for dense graded mixtures shall have at least four points, including a minimum of two points above and one point below the optimum. A one point design may be used for open graded mixtures. The maximum specific gravity shall be mass determined in water in accordance with AASHTO T 209. The bulk specific gravity of the gyratory specimens shall be determined in accordance with AASHTO T 166, Method A or AASHTO T 275, if required, for dense graded mixtures and AASHTO T 331 for open graded mixtures.

SECTION 401, BEGIN LINE 127, DELETE AND INSERT AS FOLLOWS:

VOIDS FILLED WITH ASPHALT, VFA, CRITERIA @ N_{des}	
ESAL	VFA, %
< 300,000	70 - 80
300,000 to < 3,000,000	65 - 78
3,000,000 to < 10,000,000	65 - 75
10,000,000 to < 30,000,000	65 - 75
$\geq 30,000,000$	65 - 75
Notes: 1. For 9.5 mm mixtures, the specified VFA range shall be 73% to 76% for design traffic levels ≥ 3 million ESALs.	
2. For 25.0 mm mixtures, the specified lower limit of the VFA shall be 67% for design traffic levels < 0.3 million ESALs.	
3. For 4.75 mm mixtures, the specified VFA range shall be 75% to 78% 66% to 79%. for design traffic levels ≥ 3 million ESALs.	
4. For <i>OG 9.5 mm</i> , <i>OG19.0 mm</i> , and <i>OG25.0 mm</i> mixtures, VFA is not applicable.	

SECTION 401, BEGIN LINE 152, DELETE AS FOLLOWS:

RAS may be obtained from either pre-consumer or post-consumer asphalt shingles. Post-consumer asphalt shingles shall be in accordance with AASHTO MP 15 and prepared by a processing company with an IDEM Legitimate Use Approval letter. A copy of this letter shall be submitted to the Engineer. Deleterious material present in post-consumer asphalt shingles shall be limited to the percentages stated in AASHTO MP 15. Pre-consumer and post-consumer asphalt shingles shall not be blended for use in HMA mixtures ~~and shall be stockpiled separately from other materials.~~

SECTION 401, BEGIN LINE 202, INSERT AS FOLLOWS:

401.09 Acceptance of Mixtures

Acceptance of mixtures for binder content, VMA at N_{des} , and air voids at N_{des} for each lot will be based on tests performed by the Engineer for dense graded 9.5 mm, 12.5 mm, 19.0 mm and 25.0 mm mixtures with original contract pay item quantities greater than or equal to 300 t. Acceptance of mixtures for binder content and air voids at N_{des} will be based on a type D certification in accordance with 402.09 for dense graded mixtures with original contract pay item quantities less than 300 t. *Acceptance of mixtures for binder content and air voids at N_{des} for each lot will be based on a type D certification in accordance with 402.09 for dense graded 4.75 mm mixtures.*

Acceptance of mixtures for binder content and air voids at N_{des} for each lot will be based on tests performed by the Engineer for open graded mixtures *with original contract pay item quantities greater than or equal to 300 t. Acceptance of mixtures for binder content and air voids at N_{des} will be based on a type D certification in accordance with 402.09 for open graded mixtures with original pay item quantities less than 300 t, except the air voids tolerance shall be $\pm 3.5\%$ from the DMF or JMF.*

SECTION 401, AFTER LINE 265, INSERT AS FOLLOWS:

Samples shall not be obtained from areas placed with paving equipment in accordance with 409.03(c)2 or 409.03(c)3. If a random location falls within this area, the Engineer will randomly select another location within the subplot for sampling. If an entire subplot falls within this area, test results from the previous subplot will be used for acceptance. If the previous subplot is not available, the subsequent subplot will be used for acceptance.

SECTION 401, BEGIN LINE 377, INSERT AS FOLLOWS:

The finished thickness of any course shall be at least two times but not more than four times the maximum particle size as shown on the DMF, *except 4.75 mm mixtures shall be at least 1.5 times but not more than 3 times the maximum particle size shown on the DMF.*

Vibratory rollers in accordance with 409.03(d)4 shall not be operated in vibratory mode when placing 4.75 mm mixtures. Oscillatory rollers in accordance with 409.03(d)5 will be permitted for use when placing 4.75 mm mixture but the vertical impact force capability shall not be used.

SECTION 401, AFTER LINE 437, INSERT AS FOLLOWS:

Cores shall not be obtained from areas placed with paving equipment in accordance with 409.03(c)2 or 409.03(c)3. If a random location falls within this area, the Engineer will randomly select another location within the subplot for coring. If an entire subplot falls within this area, test results from the previous subplot will be used for acceptance. If the previous subplot is not available, the subsequent subplot will be used for acceptance.

SECTION 410, AFTER LINE 231, INSERT AS FOLLOWS:

Samples shall not be obtained from areas placed with paving equipment in accordance with 409.03(c)2 or 409.03(c)3. If a random location falls within this area, the Engineer will randomly select another location within the subplot for sampling. If an entire subplot falls within this area, test results from the previous subplot will be used for acceptance. If the previous subplot is not available, the subsequent subplot will be used for acceptance.

SECTION 410, AFTER LINE 348, INSERT AS FOLLOWS:

Cores shall not be obtained from areas placed with paving equipment in accordance with 409.03(c)2 or 409.03(c)3. If a random location falls within this area, the Engineer will randomly select another location within the subplot for coring. If an entire subplot falls within this area, test results from the previous subplot will be used for acceptance. If the previous subplot is not available, the subsequent subplot will be used for acceptance.

SECTION 904, BEGIN LINE 128, INSERT AS FOLLOWS:

FINE AGGREGATE ANGULARITY		
TRAFFIC ESAL	DEPTH FROM SURFACE	
	≤ 4 in.	> 4 in.
< 300,000	<i>(Note 1)</i>	
300,000 to < 3,000,000	40 <i>(Note 1)</i>	40
3,000,000 to < 10,000,000	45	40
10,000,000 to < 30,000,000	45	40
≥ 30,000,000	45	45
<i>Note 1: For 4.75 mm mixtures, the fine aggregate angularity shall be 40 for <300,000 ESAL and 45 for 300,000 to <3,000,000 ESAL.</i>		

401-R-581 JOINT ADHESIVE

(Revised 09-19-13)

The Standard Specifications are revised as follows:

SECTION 401, AFTER LINE 388, INSERT AS FOLLOWS:

Hot poured joint adhesive in accordance with 906 shall be applied to longitudinal joints constructed between two adjacent HMA courses in the top course of dense graded intermediate mixtures and all 4.75 mm, 9.5 mm and 12.5 mm surface mixture courses. This includes joints within the traveled way as well as between any of the following: traveled way and an auxiliary lane; traveled way and a paved shoulder; and auxiliary lane and a paved shoulder.

The material shall be heated in a jacketed, double boiler melting kettle. The kettle shall have an attached pressure feed wand system with applicator shoe.

SECTION 410, AFTER LINE 312, INSERT AS FOLLOWS:

Hot poured joint adhesive in accordance with 906 shall be applied to longitudinal joints constructed between two adjacent HMA courses in the top course of dense graded intermediate mixtures and all 9.5 mm and 12.5 mm SMA surface mixture courses. This includes joints within the traveled way as well as between any of the following: traveled way and an auxiliary lane; traveled way and a paved shoulder; and auxiliary lane and a paved shoulder.

The material shall be heated in a jacketed, double boiler melting kettle. The kettle shall have an attached pressure feed wand system with applicator shoe.

The joint adhesive shall be applied to the face of the previously constructed edge at the joint using a wand applicator. Prior to application of the joint adhesive, the joint face shall be dry and free of loose material and foreign objects. The adhesive shall be applied on the joint face 1/8 in. thick at the temperature recommended by the manufacturer. Excess joint adhesive shall not be allowed to pool on the top of the previously constructed pavement course or the pavement to be overlaid. The application of the adhesive shall be made within the same day, but at least 15 minutes prior to construction of the longitudinal joint.

SECTION 410, AFTER LINE 485, INSERT AS FOLLOWS:

Joint adhesive will be measured by the linear foot in accordance with 109.01(a).

SECTION 410, AFTER LINE 492, INSERT AS FOLLOWS:

Joint adhesive will be paid for by the linear foot, complete in place.

SECTION 410, AFTER LINE 503, INSERT AS FOLLOWS:

*Joint Adhesive, _____.....LFT
course type*

SECTION 906, AFTER LINE 93, INSERT AS FOLLOWS:

5. Hot Poured Joint Adhesive

Joint adhesive is a hot applied asphalt material that is used to seal the longitudinal construction joint formed between the adjacent HMA pavement courses.

Joint adhesive shall be in accordance with the following:

<i>Test</i>	<i>Method</i>	<i>Test Results</i>
<i>Softening Point, °F (°C)</i>	<i>AASHTO T 53</i>	<i>> 170 (77)</i>
<i>Ductility @ 77°F (25°C), mm</i>	<i>AASHTO T 51</i>	<i>> 300</i>
<i>Ductility @ 39°F (4°C), mm</i>	<i>AASHTO T 51</i>	<i>> 300</i>
<i>Apparent Viscosity @ 400°F (204°C), cp</i>	<i>ASTM D 2669</i>	<i>4,000 – 11,000</i>
<i>Asphalt Compatibility</i>	<i>ASTM D 5329</i>	<i>Pass</i>
<i>Cone Penetration @ 77°F (25°C), mm</i>	<i>ASTM D 5329</i>	<i>50.0 – 100.0</i>
<i>Flow @ 140°F (60°C), mm</i>	<i>ASTM D 5329</i>	<i>< 5</i>
<i>Resilience @ 77°F (25°C), %</i>	<i>ASTM D 5329</i>	<i>> 30</i>
<i>Tensile Adhesion @ 77°F (25°C), mm</i>	<i>ASTM D 5329</i>	<i>> 500</i>
<i>Flexibility @ 0°F (-18°C)</i>	<i>ASTM D 3111</i>	<i>Pass</i>
<i>Flash Point, °F (°C)</i>	<i>AASHTO T 48</i>	<i>> 410 (210)</i>

The joint adhesive will be accepted by type A certification in accordance with 916 for each batch or lot of material furnished.

628-C-236 HANDS-FREE KITS FOR CELL PHONES

(Adopted 11-22-13)

The Standard Specifications are revised as follows:

SECTION 628, BEGIN LINE 423, DELETE AND INSERT AS FOLLOWS:

Each cellular telephone unit shall have a service coverage area that includes the project limits. Each cellular telephone unit shall include a belt clip system, a 120V AC charger, ~~and~~ a 12V DC mobile charger, *and a hands-free kit consisting of a speaker and a microphone enabling the user to operate the unit with minimal need for the use of their hands. The hands-free kit may be either wired or wireless.*

628-C-586 FIELD OFFICE COMPUTER EQUIPMENT

(Revised 11-22-13)

The Standard Specifications are revised as follows:

SECTION 628, BEGIN LINE 8, DELETE AND INSERT AS FOLLOWS:

628.02 Field Office and Laboratory Requirements

When specified, the Contractor shall provide a field office, computer ~~system~~*equipment*, office machines, field laboratory, services, equipment and supplies for the Department's exclusive use in accordance with the minimum requirements listed below.

SECTION 628, BEGIN LINE 28, DELETE AND INSERT AS FOLLOWS:

The field office shall be complete and ready for use by the Department, including all utility connections and specified computer ~~systems~~*equipment*, office machines, internet service, equipment and supplies, prior to the start of work. If the Contractor is unable to provide the permanent field office prior to the start of the work, the Engineer shall be notified in writing and the Contractor and the Engineer will agree to temporary field office arrangements prior to the start of work. A temporary field office will not be accepted by the Department for more than two months, at which time a permanent field office shall be ready for the Department's use.

SECTION 628, BEGIN LINE 191, DELETE AND INSERT AS FOLLOWS:

(c) Field Office Computer ~~System~~*Equipment*

~~When specified in the Schedule of Pay Items, the Contractor shall provide one field office computer system for the Department's exclusive use for each field office specified. The Contractor has the option to provide either a desktop or a laptop computer system in accordance with the minimum requirements listed below.~~

SECTION 628, AFTER LINE 229, INSERT AS FOLLOWS:

3. Field Office Computer Equipment for Department Provided Laptop

- a. External Monitor – 22 in. widescreen digital flat panel, with VGA and DVI connections
- b. External Keyboard – USB enhanced multimedia keyboard
- c. External Mouse – USB 2- button scroll mouse
- d. DELL E-series port replicator with AC adapter, and one DC adapter
- e. Wireless router compatible with IEEE 802.11 a/b/g, or b/g/n, and shall have 1 input and 4 output 10/100 Ethernet ports. The router shall have WI-FI protected access (WPA2-PSK, WPA-PSK) and WEP security.

34. Computer Software

SECTION 628, BEGIN LINE 248, DELETE AND INSERT AS FOLLOWS:

45. Miscellaneous Computer Requirements

The initial condition of the computer ~~system~~*equipment* shall be nearly pristine. All owner installed e-mail accounts, games, spyware, online services, applications, network or other profiles previously set up on the system shall be removed prior to placement in the field office. If the system was provided for a previous Department contract, all software not specified shall be removed prior to placement in the current field office.

The Contractor shall provide an uninterruptible power supply, UPS, minimum 120 VA, 100 Watts and full time surge suppression for each field office ~~computer system specified in the contract.~~

The Contractor shall provide all cables, connections and software required to connect the field office computer ~~system~~ to the printer and the scanner.

~~When more than one computer system is specified for a field office,~~ The Contractor shall provide either an Ethernet or wireless office network to enable all computer systems in the field office to access the field office internet service, the printer and the scanner.

SECTION 628, BEGIN LINE 311, DELETE AND INSERT AS FOLLOWS:

2. Printer

The printer shall be compatible with the computer system provided by the Contractor *or the Department* for use by the Department in the field office. The printer shall be capable of printing single-sided, black and white letter, legal and ledger US paper size documents at a rate of 20 pages per minute and capable of automatic duplex printing. More than one printer may be used to meet this requirement. *All devices shall be compatible with the Department's laptops or iPads and accommodate wireless printing from the iPads using AirPrint™ technology.*

3. Document Scanner

The document scanner shall be compatible with the computer system provided by the Contractor *or the Department* for use by the Department in the field office. The scanner shall be capable of scanning letter and legal size documents and shall have an automatic document feeder and be capable of *200 to 600 dpi* black and white resolution, *preset to 200 dpi*.

SECTION 628, BEGIN LINE 387, DELETE AND INSERT AS FOLLOWS:

(a) Additional Field Office Computer System

The additional field office computer system shall be ~~either a desktop or laptop computer system in accordance with 628.02(c)1 or 628.02(c)2 except that the monitor for a desktop system may be a 19 in. flat panel and the external monitor for a laptop system will not be required.~~ The requirements of 628.02(c)34 and 628.02(c)45 shall apply to each additional field office computer.

(b) Mobile Laptop Computer System

The mobile laptop computer system shall be in accordance with 628.02(c)2 except that the external monitor, integrated graphics card, external keyboard and port replicator with AC adapter will not be required. Mobile laptop computers will be used by the Department for contracts that do not include a field office. The requirements of 628.02(c)34 and 628.02(c)45 shall apply to each mobile laptop computer except that those requirements specifically for a field office computer will not apply.

SECTION 628, BEGIN LINE 533, DELETE AND INSERT AS FOLLOWS:

All costs necessary to provide *and maintain* the field office computer ~~system~~*equipment*, including the required software, manuals, ~~peripherals and related equipment~~, technical support and miscellaneous computer requirements shall be included in the cost of the field office.

All costs necessary to establish, install and maintain field office internet service, *both wireless and Ethernet*, including any required hardware, software, fees, monthly charges, setup, installation and technical support shall be included in the cost of the field office.

All costs necessary to provide the copier, printer, document scanner and fax machine, including setup, installation, all required connections to computers ~~systems~~, technical support and miscellaneous office machine requirements shall be included in the cost of the field office.

801-C-157 CERTIFICATION OF TEMPORARY TRAFFIC CONTROL DEVICES

(Revised 05-23-13)

Category I Devices

The Contractor shall certify that the following temporary traffic control devices to be used do not exceed the maximum values shown in the table below, and are considered crashworthy at Test Level 3 in accordance with NCHRP 350.

Device	Composition	Max. Weight	Max. Height
Single Piece	Rubber	20 lb	36 in.
Traffic Cones	Plastic	20 lb	48 in.
Tubular Markers	Rubber	13 lb	36 in.
	Plastic	13 lb	36 in.
Single Piece Drums	High Density Plastic	77 lb	36 in.
	Low Density Plastic	77 lb	36 in.
Delineators	Plastic, Fiberglass	N/A	48 in.

No lights, signs, flags, or other auxiliary attachments are included in the weight of the devices listed above. Reflective sheeting or reflective buttons are included on delineators. Maximum weights, including ballast, do not exceed the values shown in the table. "Single piece" refers to the construction of the body of the drum exclusive of a separate base, if any.

Type A or type C warning lights in accordance with the following specifications will be allowed on drums if they are firmly attached with vandal resistant 1/2 in. diameter by 4 in. cadmium plated steel bolt with nut and a 1 1/2 in. high cup washer.

1. The weight shall be no more than 5 lb.
2. The lens diameter shall be 7 to 8 in.
3. The height of the light shall be 11 to 14 in.

Category II Devices

Category II temporary traffic control devices include type III barricades, vertical panels, portable sign standards, and other light-weight traffic control devices.

Category II temporary traffic control devices shall be in accordance with the NCHRP 350, Test Level 3.

A form will be provided at the preconstruction conference for the Contractor to complete and return to the Engineer prior to the placement of category I or II traffic control devices.

801-C-237 TEMPORARY CONSTRUCTION SIGNS

(Adopted 12-19-13)

The Standard Specifications are revised as follows:

SECTION 801, BEGIN LINE 1126, INSERT AS FOLLOWS:

Each construction sign, barricade, temporary worksite speed limit sign assembly, *road closure sign assembly*, ~~portable changeable message sign~~, or flashing arrow sign will be paid for only once regardless of how many times each is moved, ~~or~~ replaced, *or how many times each is altered to change the sign message*. Payment will not be made for signs or barricades used for the convenience of the Contractor.

Additional materials necessary to place the ~~PCMS~~ *portable changeable message sign* in a secure and level manner for site conditions shall be included in the cost of the pay item. All costs to furnish, install, program, activate, deactivate, change messages, *move, replace*, and maintain the PCMS shall be included in the cost of the pay item. The cost of IP cellular phone service shall be included in the cost of the pay item.

801-M-006 MAINTAINING TRAFFIC FOR MAINTENANCE OR RESURFACE WORK

(Revised 09-01-05)

The Standard Specifications are revised as follows:

SECTION 801, AFTER LINE 150, INSERT AS FOLLOWS:

Traffic shall be maintained for maintenance activities or for HMA resurface work as shown on the plans or as described herein. The Contractor shall have an extra set of construction signs and an extra flashing arrow sign on the project site so that the taper may be moved forward without suspending the operations and clearing the work area. Additional traffic control devices shall be furnished for situations determined to be more complex, for protection in hazardous areas, and when traffic conditions warrant.

All non-fixed signs shall be removed at the completion of each day's operations. All lanes shall be open to normal traffic during hours other than daylight hours. If a traffic lane is directed to remain closed during hours other than daylight hours, traffic shall be maintained on the remaining lanes as shown on the plans.

All fixed signs shall remain in place until all temporary pavement markings have been removed. Work days will not be charged from the time of completion of other work until the markings have been removed.

801-R-542 WORKSITE ADDED PENALTY SIGNS

(Revised 06-25-07)

Worksite Added Penalty signs shall be placed as shown in the plans or as directed by the Engineer. The signs shall typically be placed in advance of the first Road Construction Ahead signs at either end of the project. The actual location and quantity of the signs will be determined by the Engineer in coordination with the Worksite Traffic Control Supervisor.

The XG20-7a "WORKSITE ADDED PENALTY SIGN, 60 x 36" shall only be installed on projects in urban areas that have a posted speed limit of 35 MPH or less and also meet one of the following conditions:

1. The existing surfaces outside the edge of pavement make installation of driven posts impractical, or
2. The width of the Right-of-Way outside of the edge of pavement is not sufficient to accommodate the larger XG20-7 "WORKSITE ADDED PENALTY SIGN, 78 x 42" sign.

The XG20-7b and XG20-7c "WORKSITE ADDED PENALTY SIGNS, 48 x 48" shall be used in series with each other and shall only be used on projects that meet one of the following conditions:

1. Rural projects where the width of the Right-of-Way outside of the edge of pavement is not sufficient to accommodate the larger XG20-7 "WORKSITE ADDED PENALTY SIGN, 78 x 42" sign, or
2. Contracts using only moving operations where construction signs are set and removed each day to accommodate the changing location of the work.

The XG20-7 "WORKSITE ADDED PENALTY SIGN, 78 x 42" shall be installed on all projects in all cases not otherwise described above.

Worksite Added Penalty signs will be measured and paid for as Construction Sign, Type C in accordance with 801.17 and 801.18.

801-T-194 AUTOMATED FLAGGER ASSISTANCE DEVICE

(Adopted 05-16-13)

The Standard Specifications are revised as follows:

SECTION 801, BEGIN LINE 11, INSERT AS FOLLOWS:

801.02 Materials

Materials shall be in accordance with the following:

Automated Flagger Assistance Devices.....923.08

SECTION 801, AFTER LINE 791, INSERT AS FOLLOWS:

(e) Automated Flagger Assistance Devices

An Automated Flagger Assistance Device, AFAD, may be used to control a single lane of approaching traffic on a two-lane highway for flagging operations.

Only qualified flaggers who have been trained on the operation of the AFAD shall operate the AFAD. AFAD operators shall be able to provide written proof that they have been trained by the AFAD manufacturer. Two trained flaggers shall be available on-site to provide flagging in case of an AFAD malfunction. The flagger operating the AFAD shall be positioned to have unobstructed line of sight to approaching traffic and the AFAD. A single flagger may be used to control both approaches to the work site if adequate, unobstructed sight distance exists between the AFAD operator and both approaching directions of traffic and both AFADs.

The flagger operating the AFAD shall not leave the device unattended at any time while the AFAD is in use. The operating flagger shall be positioned at such point to be in full view of oncoming traffic and the AFAD at all times the AFAD is in use. The flagger operator shall keep a back up hand held remote readily available at all times when the device is being operated.

The AFAD shall be positioned so that the end of the gate arm, if used, shall extend at least to the center of the lane being controlled but shy of the roadway centerline.

A drum shall be placed immediately in front of the AFAD trailer at both corners for delineation.

SECTION 801, BEGIN LINE 1148, INSERT AS FOLLOWS:

The cost of necessary flaggers; *automated flagger assistance devices*; protection of traffic at structure foundations; and furnishing, erecting, placing, maintaining, relocating, and removing lights, cones, flexible channelizers, tubular markers, drums, delineators, or other devices as directed shall be included in the cost of maintaining traffic.

SECTION 923, BEGIN LINE 238, INSERT AS FOLLOWS:

923.08 Automated Flagger Assistance Device

The Automated Flagger Assistance Device, AFAD, shall alternately display a STOP sign and a SLOW sign to control traffic while being operated by a hand held remote control. AFADs shall meet the requirements of the Indiana Manual on Uniform Traffic Control Devices, Chapter 6E. Each AFAD shall be equipped with two hand held remote controls. Trailer mounted AFAD's shall be equipped with a gate arm.

Only automated flagger assistance devices from the List of Approved Solar Powered Traffic Control Devices shall be used. Automated flagger assistance devices will be placed and maintained on the list of approved Solar Powered Traffic Control Devices in accordance with ITM 955.

(a) Signs

The STOP and SLOW signs shall have a minimum width of 24 in. with lettering that is at least 8 in. in height. The WAIT ON STOP sign shall be visible along the same line of view of the STOP sign face.

(b) Supplemental Conspicuity Devices

The STOP sign face shall be supplemented by a circular, red stop beacon. The SLOW sign face shall be supplemented by either: a circular, yellow warning beacon, or Type B warning lights with a minimum viewing distance of 1000 ft.

(c) Gate Arm

Gate arms shall be made of reinforced thermoplastic or tubular aluminum. When in the horizontal positions the arm shall have a 2 ft to 4 ft mounting height above the pavement surface

(d) Cabinets and Controller

The battery and controller cabinets shall be in accordance with NEMA Standard 250 Enclosure 3R requirements and be provided with a hasp and lock. The AFAD shall include a manual override of the hand held remote at the device. The AFAD shall not have any means by which it can operate on a pre-set or pre-timed basis.

(e) Remote Control Device

Two hand held, cordless remote controls shall be provided with each AFAD. The remote control shall be waterproof and display signal receipt confirmation. The remote shall use a frequency hopping, spread spectrum radio signal with frequencies outside the 700MHz band, 698 MHz to 806 MHz. The remote control device shall be programmable to control either one unit or two units simultaneously and shall control the units over a one-mile range. Remote control batteries shall be rechargeable. A recharging device shall be provided with each remote.

(f) Batteries and Charging System

Batteries shall be deep cycle type and be capable of operating the AFAD continuously for two days, 24 hrs per day without a need of re-charging. An audible low battery voltage alarm sound system shall be provided. The battery charging system shall consist of a solar panel. Solar panels shall be UL 1703 certified.

(g) Trailer

The trailer, if used, shall be designed to withstand a 60 mph wind loading with a 1.3 gust factor when the AFAD is set up in operating position. The trailer shall be painted safety orange, Federal Standard 595, color No. 12300. The trailer shall be provided with a minimum of two leveling jacks, each operated by a crank which locks in place.

923.089 Acceptance of Temporary Traffic Control Devices

Temporary traffic control devices will be accepted by visual inspection unless otherwise indicated.

801-T-198 TRAFFIC CONTROL FOR TRAFFIC BREAKS

(Adopted 07-17-13)

The Standard Specifications are revised as follows:

SECTION 801, BEGIN LINE 795, DELETE AND INSERT AS FOLLOWS:

801.16 Temporary Traffic Control Zone

A temporary traffic control zone is a work zone with frequently changing operation, a maximum duration of seven calendar days; mobile operation; or a temporary traffic stoppagebreak.

SECTION 801, BEGIN LINE 829, DELETE AND INSERT AS FOLLOWS:

(c) Traffic Control for Temporary Traffic StoppageBreaks

Traffic shall not be allowed to pass directly beneath personnel or equipment working on an overhead structure. Traffic breaks, when approved by the Engineer, may be implemented for moving equipment or materials over the traveled way. Traffic breaks shall be accomplished by temporary stoppage, rolling slowdown or other approved method. Traffic stoppage breaks during an overhead operation shall not exceed 20 minutes at one time. There shall be enough time between consecutive stoppagebreaks to allow traffic to return to normal flow.

Three working days prior to commencing work which necessitates ~~temporary stoppage~~ *breaks* of traffic, written notice shall be given to the Department and the Indiana State Police that highway traffic shall be stopped, *slowed or diverted* temporarily at a specific location, time, and date to accomplish specified work. Traffic shall be safely controlled during the ~~stoppage~~ *traffic break*. The following minimum requirements shall be met.

1. On Multi-Lane Divided Highways

Advance warning signs *and pilot vehicles* shall be located as specified or as otherwise directed. ~~For each direction of road closure two flaggers shall be located at the site of the work and a minimum of two additional flaggers shall be used to warn approaching traffic.~~

2. On Non-Divided Highways

Advance warning signs shall be located as specified or as otherwise directed. For each direction of road closure, *a minimum of one* flagger shall be located at the site of the work and a minimum of one additional flagger shall be used to warn approaching traffic.

805-T-078 ELECTRICAL INSULATION SEALANT

(Adopted 09-01-05)

The electrical insulation sealant for this contract shall be chosen from the following list:

- (a) Aquaseal
- (b) Electrical 430
- (c) 3M Electrical Insulation Putty
- (d) Plyseal Insulating Mastic
- (e) or approved equal

808-T-190 LONGITUDINAL RUMBLE STRIPES

(Adopted 05-16-13)

The Standard Specifications are revised as follows:

SECTION 401, BEGIN LINE 458, DELETE AND INSERT AS FOLLOWS:

401.17 ~~Shoulder~~Pavement Corrugations

~~Shoulder~~Pavement corrugations shall be in accordance with 606.

SECTION 402, BEGIN LINE 81, DELETE AND INSERT AS FOLLOWS:

402.07 Mix Criteria

(a) Composition Limits for HMA *Transverse Rumble Strip Mixtures*

Transverse Rumble strip mixtures shall be type A surface in accordance with 402.04. A MAF in accordance with 402.05 will not apply. Aggregate requirements of 904.03(d) do not apply.

SECTION 402, BEGIN LINE 278, DELETE AND INSERT AS FOLLOWS:

Transverse Rumble strips shall be placed to ensure uniformity of depth, width, texture, and the required spacing between strips. A tack coat in accordance with 406 shall be applied on the pavement surface prior to placing the mixture. The tack coat may be applied with a paint brush or other approved methods.

SECTION 402, BEGIN LINE 346, DELETE AND INSERT AS FOLLOWS:

Transverse Rumble strips shall be compacted with vibratory compacting equipment in accordance with 409.03(d)7 unless otherwise stated.

SECTION 402, BEGIN LINE 395, DELETE AND INSERT AS FOLLOWS:

402.17 ~~Shoulder~~Pavement Corrugations

~~Shoulder~~Pavement corrugations shall be in accordance with 606.

SECTION 402, BEGIN LINE 425, INSERT AS FOLLOWS:

HMA *Transverse Rumble Strips* LFT

SECTION 501, BEGIN LINE 372, DELETE AND INSERT AS FOLLOWS:

501.24 ~~Shoulder~~Pavement Corrugations

~~Shoulder~~Pavement corrugations shall be in accordance with 606.

SECTION 502, BEGIN LINE 359, DELETE AND INSERT AS FOLLOWS:

502.19 ~~Shoulder~~Pavement Corrugations

~~Shoulder~~Pavement corrugations shall be in accordance with 606.

SECTION 606, BEGIN LINE 1, DELETE AND INSERT AS FOLLOWS:

SECTION 606 – ~~SHOULDER~~PAVEMENT CORRUGATIONS

606.01 Description

(a) All Corrugations

This work shall consist of placing corrugations in the ~~paved shoulders~~*pavement* in accordance with 105.03. Corrugations shall not be constructed within the limits of reinforced concrete bridge approaches or in bridge decks.

The operation shall be coordinated such that milled materials do not encroach on the pavement lanes carrying traffic and all milled materials are disposed of in accordance with 104.07. *When corrugations are installed for center line and edge line rumble stripes, milled materials shall be swept and vacuumed following the milling operation.*

The corrugation shall be constructed by cutting smooth strips in existing or newly constructed ~~shoulders~~ *pavement*. The operation shall be conducted by means of a cutting machine that provides a series of smooth cuts without tearing or snagging. The equipment shall include guides to maintain uniformity and consistency in the alignment of the strips.

Longitudinal rumble stripes are the combination of either the center line pavement marking placed in the center line corrugation or the edge line pavement marking placed in the edge line corrugation. They shall be installed as shown in the plans and as specified herein.

(b) Center Line and Edge Line Corrugations

When corrugations are installed for center line and edge line rumble stripes control points that are required as a guide for milling corrugations shall be spotted with paint for the full length of the road to be milled. Control points along tangent sections shall be spaced at a maximum interval of 100 ft. Control points along curve sections shall be spaced to ensure the accurate location of the milled corrugations. The location of control points shall be approved prior to the milling operations.

If snowplowable raised pavement markers exist where center line corrugations are being placed into the existing surface, the prismatic reflectors in these markers shall be removed and corrugations gapped a maximum of 60 in. and not within 6 in. of the markers.

In the presence of D-1 pavement joints or castings which conflict with the location of the corrugations, the corrugations shall be gapped a maximum of 5 ft and not within 6 in. of the joint or casting.

Corrugations installed within the HMA traveled way and on HMA shoulder contiguous with a HMA traveled way or a HMA auxiliary lane shall be sealed using liquid asphalt sealant in accordance with 401.15.

1. Installation Tolerances

Lateral deviation of milled center line or edge line corrugations shall not exceed 1 in. in 100 ft. The alignment of all pavement markings placed within rumble stripes shall be $\pm 1/2$ in. of its specified location.

2. Maintenance of Traffic

The rumble stripe traffic control procedures shall be submitted to the Engineer and shall be in accordance with 808.08. Vehicles used in performing the milling, sweeper, vacuum or sealing operations shall have a rear escort vehicle that follows at a distance of 100 to 500 ft.

606.02 Method of Measurement

*HMA and PCCP ~~shoulder~~ *pavement* corrugations will be measured by the linear foot, measured parallel to the center line of the roadway. Gaps in PCCP ~~shoulder~~ *pavement* corrugations at the D-1 joints will be included in the milled PCCP corrugations. Gaps in *pavement* corrugations for castings will be included in the milled corrugations.*

606.03 Basis of Payment

HMA and PCCP ~~shoulder~~ *pavement* corrugations will be paid for at the contract unit price per linear foot, when specified.

Payment will be made under:

Pay Item	Pay Unit Symbol
Milled HMA Shoulder Corrugations	LFT
Milled PCCP Shoulder Corrugations	LFT

The cost of removal of existing prismatic reflectors in rumble strip retrofit sections shall be included in the cost of the pay items.

Milling, sweeping, vacuum cleaning, operation protection and maintenance of traffic associated with these pay items and all necessary incidentals shall be included in the cost of the pay items.

Where corrugations are placed in an existing HMA surface, liquid asphalt sealant shall be included in the cost of the pay items.

SECTION 808, BEGIN LINE 53, INSERT AS FOLLOWS:

808.04 Longitudinal Markings

All longitudinal lines shall be clearly and sharply delineated, straight and true on tangent, and form a smooth curve where required. Lines shall be square at both ends, without mist, drip or spatter.

A solid line shall be continuous. A broken line shall consist of 10 ft line segments with 30 ft gaps.

All lines shall be gapped at intersections unless otherwise specified or directed.

The actual repainting limits for no-passing zone markings will be determined by the Engineer.

A new broken line placed over an existing broken line shall laterally match the existing broken line, and the new line segments shall not extend longitudinally more than 10% beyond either end of the existing line segments.

(a) Center Lines

Center lines shall be used to separate lanes of traffic moving in opposite directions. All center line markings shall be yellow in color and 4 in. in width. They shall be placed such that the edge of the marking, nearest to the geometric centerline of the roadway, shall be offset 4 in. from the geometric centerline.

The center line of a multi-lane roadway shall be marked with a double solid line. The 2 lines forming the double solid line shall be spaced 8 in. apart and shall be equally offset on opposite sides of the geometric centerline.

The center line of a 2-lane, 2-way roadway, where passing is allowed in both directions, shall be marked with a broken line.

The center line of a 2-lane, 2-way roadway, where passing is allowed in 1 direction only, shall be marked with a double line, consisting of a broken line and a solid line. The broken line and the solid line shall be spaced 8 in. apart and shall be equally offset on opposite sides of the geometric centerline. The solid line shall be offset toward the lane where passing is prohibited. The broken line shall be offset toward the lane where passing is permitted.

The center line shall be placed within the milled corrugation when center line rumble stripes are specified. Placement of the center line marking in the milled corrugation does not alter the pavement marking performance requirements of section 808.07.

(b) Lane Lines

Lane lines shall be used to separate lanes of traffic moving in the same direction. Normal lane line markings shall be white in color and shall be 5 in. wide on freeways, interstates and toll roads, and 4 in. wide on all other roads. They shall be offset 4 in. to the right of longitudinal pavement joints or divisions between traffic lanes. Normal lane lines shall be marked with white broken lines. White solid lines shall be used to mark lane lines only when specified or directed.

(c) Edge Lines

Edge lines shall be used to outline and separate the edge of pavement from the shoulder. Edge line markings shall be 4 in. in width and shall be placed such that the edge of the marking nearest the edge of the pavement shall be offset 4 in. from the edge of the pavement except as otherwise directed. Right edge lines shall be marked with a white solid line and left edge lines shall be marked with a yellow solid line.

The edge line shall be placed in the milled corrugation when edge line rumble stripes are specified. Placement of the edge line marking in the milled corrugation does not alter the pavement marking performance requirements of section 808.07.

(d) Barrier Lines

Barrier lines shall be used as specified or directed. Barrier line markings shall be solid lines of the size and color specified or as directed.

(e) Markings in Retrofitted Corrugations

In sections where corrugations are being placed in the existing surface all existing pavement markings shall be removed in accordance with 808.10 and any existing sealants shall be routed or grinded out. Temporary pavement markings placed in accordance with 801.12 shall be offset a sufficient distance from the longitudinal joint so as to not to obstruct the installation of the corrugations or the application of the liquid asphalt sealant.

The Contractor shall make a record of the existing pavement marking locations so that such markings may be replicated later with the appropriate adjustments for edge line rumble stripes. This record shall show longitudinal and transverse dimensions. The record shall be submitted to and approved by the District Traffic Engineer prior to the removal of existing pavement markings. The District Traffic Section shall be notified two weeks prior to applying pavement markings so as to allow the District Traffic Section to verify the pavement marking plan.

107-R-169 STATEMENTS ABOUT EXISTING CONDITIONS OF UTILITIES, ADDITIONAL
RIGHT-OF-WAY, AND ENCROACHMENTS

(Revised 05-23-13)

The Standard Specifications are revised as follows:

SECTION 107, AFTER LINE 755, INSERT AS FOLLOWS:

107.26 Existing Conditions of Utilities, Additional Right-of-Way, and Encroachments
Such existing conditions are as described below.

(a) Utilities

There is no known involvement of utility companies or organizations located within the project limits.

(b) Right-of-Way

There is no involvement of additional right-of-way for the contract.

(c) Encroachments

There is no involvement of encroachments for the contract.

(d) Other Noteworthy Conditions

There are no other noteworthy conditions which may affect the prosecution and progress of the contract.

(e) Preconstruction Conference Notification

The Contractor shall provide notification during the preconstruction conference about known corrections to or omissions of the information presented in 107.26(a) through 107.26(d) above. Otherwise, notification shall be provided as required in 105.06. Notifications regarding such corrections or omissions shall not alleviate the Contractor's inquiry or interpretation obligations as contained in 105 IAC 11-3-7.

414-R-609 COST OF CLOSURE PERIODS FOR UBWC REMEDIAL WORK

(Adopted 11-16-12)

The Standard Specifications are revised as follows:

SECTION 414, AFTER LINE 260, INSERT AS FOLLOWS:

The costs of closure periods for remedial work will be assessed using the following closure periods rates:

From 6:00 am to 7:00 pm:.....\$600/lane/hour
From 7:00 pm to 6:00 am:.....\$600/lane/hour

HMA PATCHING, TYPE C

It is to be noted that HMA PATCHING, TYPE C may involve either full depth removal and replacement of the pavement structure or it may involve partial depth removal and replacement of the top portion of the pavement structure. For either type of work the price will be as per the item unit price.

The contactor shall allow 5 working days after staking and stationing are completed prior to commencing patching operations to allow INDOT personnel time to observe and document areas to be patched. The contractor shall have temporary signage in place and provide station information prior to the beginning of the 5 working days.

**INDIANA DEPARTMENT
OF
TRANSPORTATION**

**CONTRACT INFORMATION
BOOK (CIB)**

PART II

CONSTRUCTION DRAWINGS

CONTRACT NO. _____

Federal Road Region 5	
TRAFFIC DATA	
A.A.D.T. (2013)	7640 V.P.D.
A.A.D.T. (2034) Proj.	8930 V.P.D.
D.H.V. (2034)	9.26 V.P.H.
Directional Distribution	49.81
Trucks 13.29% D.H.V.	16.24% A.A.D.T.
DESIGN DATA	
Design Speed	55
Project Design Criteria	PARTIAL 3R (NON-FREEWAY)
Functional Class	MINOR ARTERIAL
Rural/Urban	RURAL
Terrain	LEVEL

LATITUDE:	N 38°21'37"
LONGITUDE:	W 86°5'49"

PLANS PREPARED BY: Craig E. Allman, P.E.

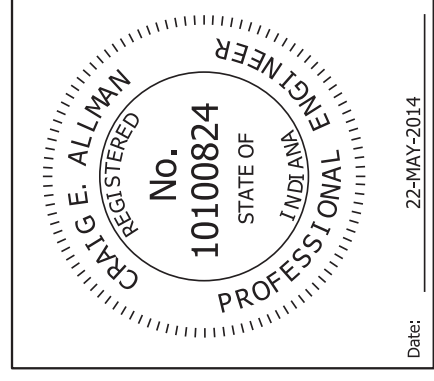

Date: 22-MAY-2014

2014.05.22
12:52:29 -04'00'

Jane P. Twaddle
2014.06.13 07:51:58
-04'00'

INDIANA DEPARTMENT OF TRANSPORTATION

INDIANA DEPARTMENT OF TRANSPORTATION

ROAD PLANS

PROJECT DESCRIPTION

Ultra Thin Bonded Wearing Course Project

PROJECT LOCATION

This project consists of Patch And Rehab Bituminous Pavement on S.R. 135, from S.R. 64 (RP 21+87) to U.S. 150 (RP 28+62) in Harrison County.

Gross Length 6.67 MI.

Net Length N/A MI.

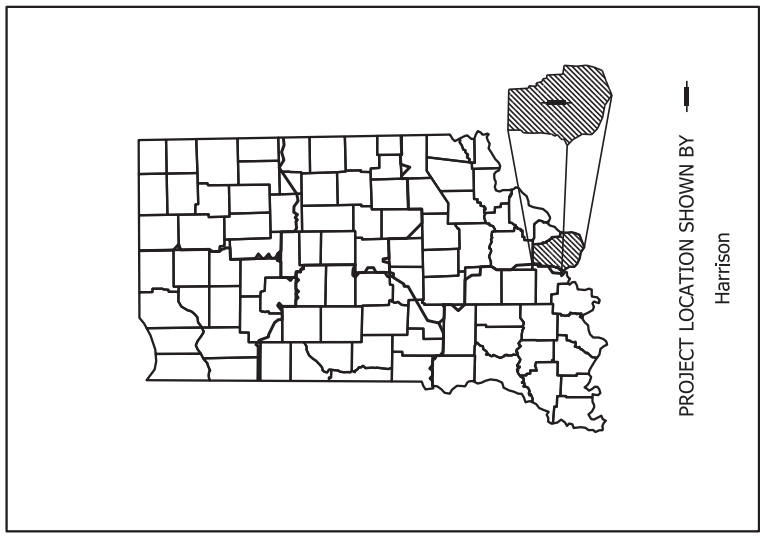

PROJECT LOCATION SHOWN BY Harrison

DES. NO. 1297609

END PROJECT

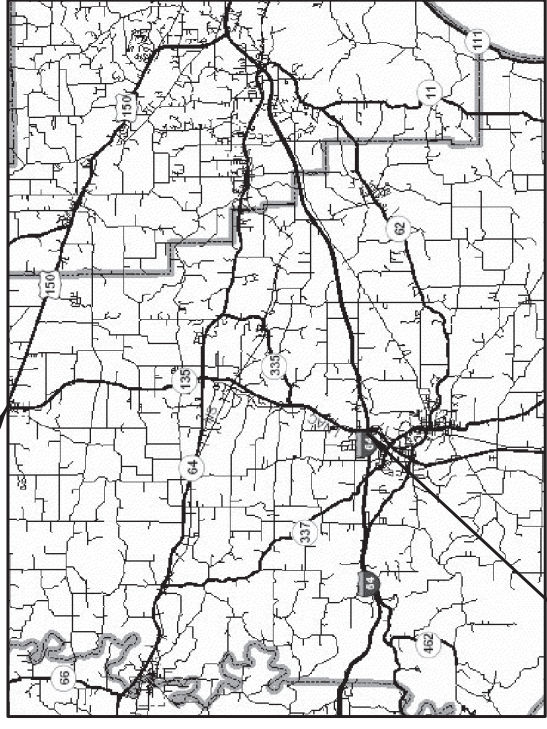

BEGIN PROJECT

CERTIFIED BY:

APPROVED FOR LETTING:

Indiana Department of Transportation
Standard Specifications dated 2014
to be used with these plans.

INDEX SHEET

TITLE SHEET	1
INDEX SHEET	2
GENERAL NOTES AND UTILITY INFORMATION	3
TYPICAL SECTIONS	4-5
CONSTRUCTION SIGN LAYOUT / STRIP MAP	6-8
DETAIL SHEET - I-64 RAMP INTERSECTION	9
DETAIL SHEET - PALMYRA CURB RAMP LOCATIONS	10
DETAIL SHEET - CURB RAMP PAY LIMIT DETAILS	11
DETAIL SHEET - HMA PATCHING DETAILS	12
PAVEMENT MARKINGS TABLE	13-15
CURB RAMP TABLE	16
PAVEMENT MARKINGS TABLE TOTALS	17
QUANTITY TABLES	18

GENERAL NOTES AND UTILITY INFORMATION

GENERAL NOTES

1. Locations and stationing are provided for information only. All widths and distances shall be field verified.
2. Undistributed quantities of centerline and edgeline markings are given to maintain existing centerline and edgeline markings. INDOT personnel will provide actual marking locations and quantity.
3. Maintain positive drainage at all curb lines.
4. Maintain a minimum of 25' paving exception north and south of the railroad tracks.

INDIANA UNDERGROUND PLANT PROTECTION SERVICE, INC.



**Know what's below.
Call before you dig.**

Per Indiana State Law IC-8-1-26-16, It is against the law to excavate without notifying the underground location service two (2) working days before commencing work.

**INDIANA UNDERGROUND
1-800-382-5544 OR CALL 811
24 HOURS A DAY 7 DAYS A WEEK**

Note: Utility Locations are shown based upon information (maps and paint marks) supplied by others, and there is no guarantee of the accuracy or completeness of said locations

TYPICAL SECTIONS

S.R. 135 Mainline

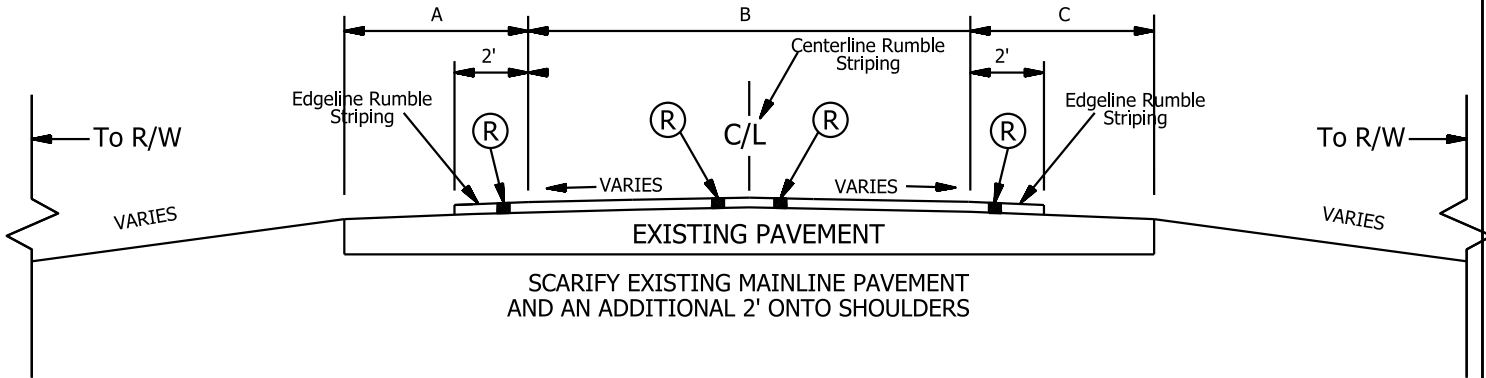

Sta. 10+00 to 318+75

Note: Sta. 10+00 to 27+00 widths and distances are provided on a detail sheet

STATION	A	B	C	NOTES
27+00 TO 27+40	12.0'	60.0'	12.0'	
27+40 TO 31+75	1.0'	42.0'	12.0'	
31+75 TO 33+60	7.0'	24.0'	7.0'	
33+60 TO 51+02	2.0'	24.0'	2.0'	
51+02 TO 52+45	2.0'	30.0'	2.0'	
52+45 TO 52+80	2.0'	36.0'	2.0'	
52+80 TO 53+51	0.0'	42.0'	0.0'	
53+51 TO 55+40	0.0'	48.0'	0.0'	
55+40 TO 57+40	0.0'	36.0'	0.0'	
57+40 TO 140+75	2.0'	24.0'	2.0'	
140+75 TO 141+75	4.0'	30.0'	4.0'	
141+75 TO 146+80	4.0'	36.0'	4.0'	
146+80 TO 148+90	4.0'	42.0'	4.0'	
148+90 TO 150+75	4.0'	48.0'	4.0'	
150+75 TO 152+00	4.0'	42.0'	4.0'	
152+00 TO 152+55	4.0'	36.0'	4.0'	
152+55 TO 154+95	4.0'	30.0'	4.0'	
154+95 TO 284+55	2.0'	24.0'	2.0'	
284+55 TO 305+90	12.0'	24.0'	12.0'	
305+90 TO 307+50	6.0'	36.0'	6.0'	
307+50 TO 310+15	0.0'	48.0'	0.0'	
310+15 TO 311+90	4.0'	48.0'	4.0'	
311+90 TO 313+40	4.0'	36.0'	4.0'	
313+40 TO 318+25	4.0'	30.0'	4.0'	
318+25 TO 318+75	2.0'	24.0'	2.0'	

LEGEND

Ⓡ Ultra-Thin Bonded Wearing Course (UBWC), 9.5mm

TYPICAL SECTIONS (CONTINUED)

S.R. 135 Mainline

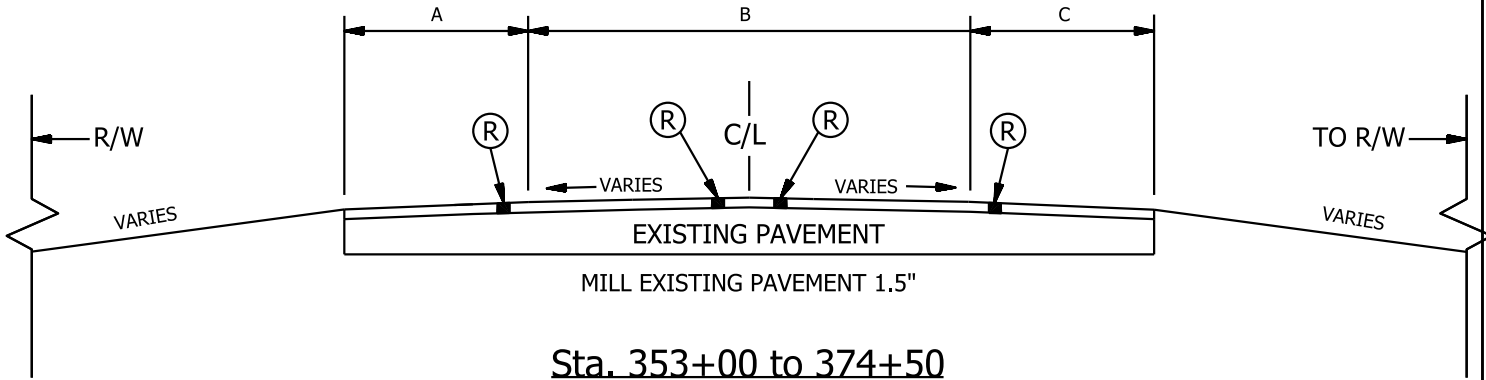

STATION	A	B	C	NOTES
353+00 TO 355+25	2.0'	24.0'	8.0'	
355+25 TO 355+85	0.0'	40.0'	0.0'	
355+85 TO 360+72	0.0'	40.0'	0.0'	Curbed Left Side
360+72 TO 374+50	0.0'	40.0'	0.0'	Curbed Both Sides

LEGEND

Ⓡ 165 Lbs./Sq. Yd. of QC/QA HMA Surface, 3, 70, 9.5mm

CONSTRUCTION SIGN LAYOUT/STRIP MAP

Sival Rd.
Sta. 165+40

Scale: N.T.S.



S.R. 135

② ① ④

S.R. 335
Sta. 149+95

③

Sky Aire Rd.
Sta. 124+60

Old. S.R. 135
Sta. 124+60

①

①

Railroad Crossing
Sta. 116+79

①

Old. S.R. 135
Sta. 86+88

Angelo Rd.
Sta. 58+43

①

General Rd.
Sta. 54+73

①

Old. S.R. 135
Sta. 54+73

①

Railroad Crossing
Sta. 33+58

Old. S.R. 135
Sta. 31+00

Quarry Rd.
Sta. 26+45

①

Quarry Rd.
Sta. 26+45

①

Onbound Ramp I-64
Sta. 14+80

③

Offbound Ramp I-64
Sta. 14+80

④ ① ②

End Overpass Bridge
Begin Project and Paving
Sta. 10+00

③

②

①

④

Construction Signs

- ① Road Construction Ahead
- ② Road Construction Next 6 Miles
- ③ End Construction
- ④ Worksite Added Penalty Sign

CONSTRUCTION SIGN LAYOUT/STRIP MAP (CONTINUED)

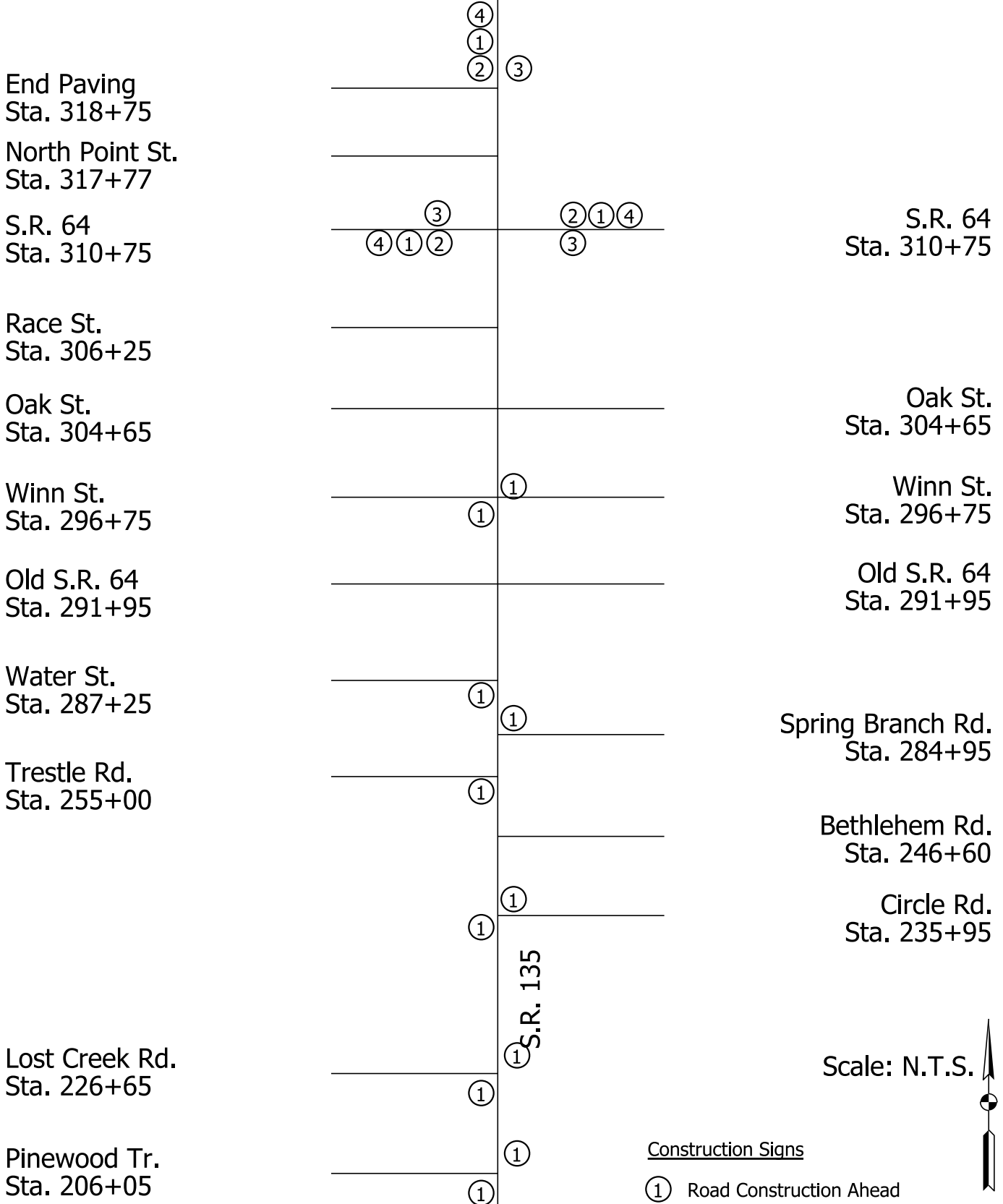

Construction Signs

- (1) Road Construction Ahead
- (2) Road Construction Next 6 Miles
- (3) End Construction
- (4) Worksite Added Penalty Sign

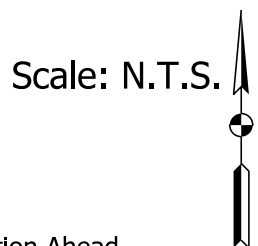

CONSTRUCTION SIGN LAYOUT/STRIP MAP (CONTINUED)

SCALE: N.T.S.



End Paving and Project
Sta. 374+50

U.S. 150/Main St.
Sta. 374+20

U.S. 150/Main St.
Sta. 374+20

Church St.
Sta. 370+90

Church St.
Sta. 370+90

Avery St.
Sta. 367+85

Avery St.
Sta. 367+85

Catherine St.
Sta. 365+00

Heuser St.
Sta. 360+40

Heuser St.
Sta. 360+40

Marshall St.
Sta. 355+95

Kahl St.
Sta. 357+50

Begin Paving
Sta. 353+00

Voyles St.
Sta. 354+45

④
①
② ③

③
④ ① ② ② ① ④
③

S.R. 135

①
①

①
①

①
①

③ ②
①
④

CONSTRUCTION SIGNS:

- ① ROAD CONSTRUCTION AHEAD
- ② ROAD CONSTRUCTION NEXT 7 MILES
- ③ END CONSTRUCTION
- ④ WORKSITE ADDED PENALTY SIGN

DETAIL SHEET - I-64 RAMP INTERSECTION

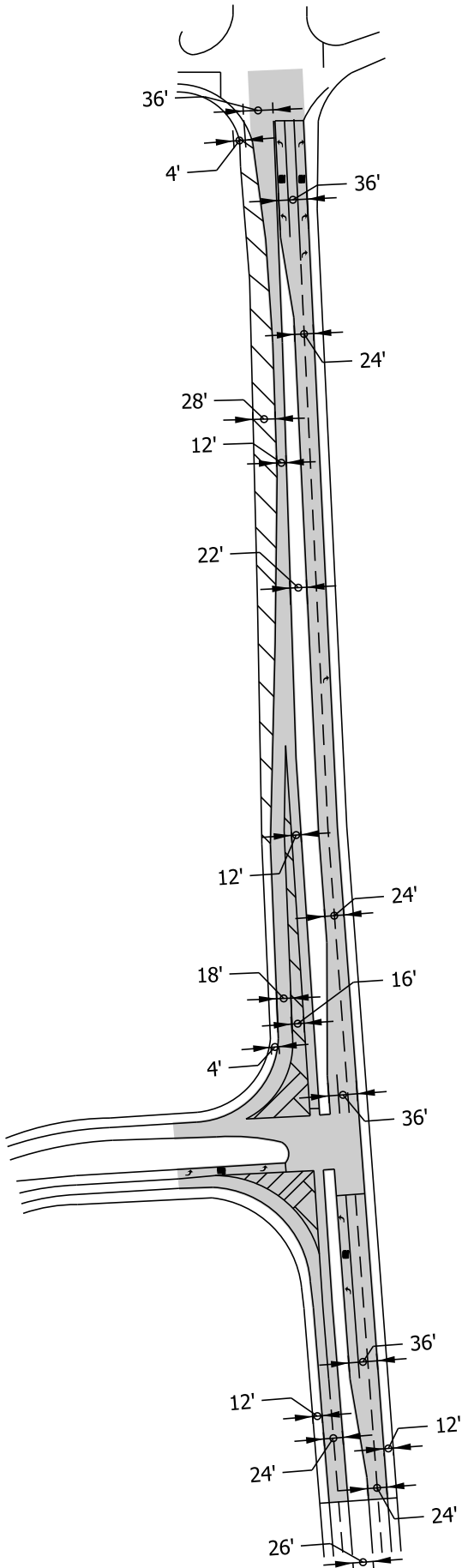

- C/L Quarry Rd. / Sky Park Dr.
Sta. 26+45
- 36' of Stop Bar
Sta. 26+00
- 2 Lane Indication Arrows
Sta. 25+70
- 2 Words "ONLY"
Sta. 25+30
- 2 Lane Indication Arrows
Sta. 24+90
- Lane Indication Arrow
Begin White Line
Sta. 24+50
- Begin Lane Taper Rt.
Sta. 23+55
- Begin Lane Taper Lt.
Sta. 23+25
- 1 Detector Housing and 2 Loops
Sta. 22+70
- End Lane Taper Lt.
Sta. 22+50
- Lane Indication Arrow
Sta. 19+90
- End White Gore Lt.
Begin Lane Taper Lt.
Sta. 19+05
- Begin White Gore Lt.
Sta. 17+80
- End Taper Rt.
Sta. 16+45
- Begin Taper Rt.
Sta. 15+40
- 12' of Stop Bar
Sta. 15+35
- Begin White Gore Striping Lt.
Sta. 15+25
- C/L Ramps to I-64
Sta. 14+80
- 36' of Stop Bar
Sta. 14+30
- 1 Detector Housing and 4 Loops
Sta. 14+07
- Lane Indication Arrow
Sta. 13+95
- Word "ONLY", Begin Gore Striping Lt.
Sta. 13+58
- Lane Indication Arrow
Sta. 13+18
- End Lane Taper Rt.
Begin White Line
Sta. 12+80
- Begin Lane Taper Rt.
1 Detector Housing and 2 Loops
Sta. 11+00
- Begin Project and Paving
Sta. 10+00



Depicts Paving Area
(with 2' onto shoulders)

Area = 130,295 Sft.
= 14,500 Syd.

DETAIL SHEET - PALMYRA CURB RAMP LOCATIONS

Curb Ramp, Type "G"

Church St.
Sta. 370+90

Curb Ramp, Type "G"

Church St.
Sta. 370+90

Curb Ramp, Type "G"
Curb Ramp, Type "G"

Avery St.
Sta. 367+85

Curb Ramp, Type "G"
Curb Ramp, Type "G"

Avery St.
Sta. 367+85

Curb Ramp, Type "G"
Curb Ramp, Type "G"

Catherine St.
Sta. 365+00

Curb Ramp, Type "G"

Curb Ramp, Type "G"
Curb Ramp, Type "G"

Heuser St.
Sta. 360+40

Curb Ramp, Type "G"

Heuser St.
Sta. 360+40

Curb Ramp, Type "G"
Curb Ramp, Type "G"
Match to Side Road
Sidewalk

Marshall St.
Sta. 355+95

Kahl St.
Sta. 357+50



Mainline S.R. 135

SCALE: N.T.S.

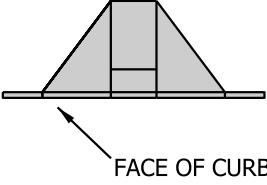
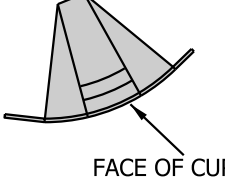
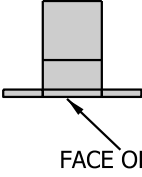
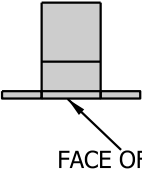
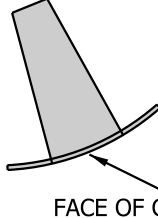
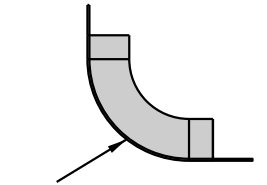
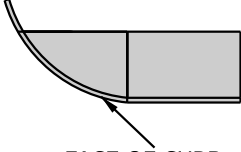
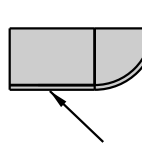

DETAIL SHEET - CURB RAMP PAY LIMIT DETAILS

CURB RAMP PAY LIMITS

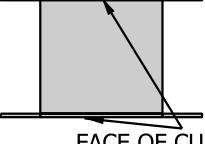
<p>CURB RAMP TYPE A</p>  <p>FACE OF CURB</p>	<p>CURB RAMP TYPE B</p>  <p>FACE OF CURB</p>	<p>CURB RAMP TYPE C</p>  <p>FACE OF CURB</p>	<p>CURB RAMP TYPE D</p>  <p>FACE OF CURB</p>	<p>CURB RAMP TYPE E</p>  <p>FACE OF CURB</p>
<p>CURB RAMP TYPE F</p>  <p>FACE OF CURB</p>	<p>CURB RAMP TYPE G</p>  <p>FACE OF CURB</p>	<p>CURB RAMP TYPE H</p>  <p>FACE OF CURB</p>	<p>CURB RAMP TYPE K</p>  <p>FACE OF CURB</p>	<p>CURB RAMP TYPE L</p>  <p>FACE OF CURB</p>

PAY LIMIT DETAIL OF CURB WITH GUTTER

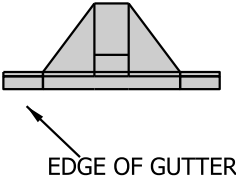
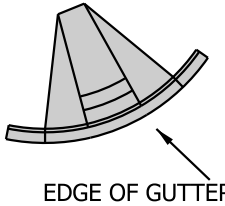
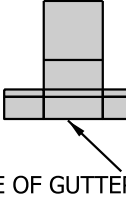
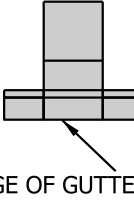
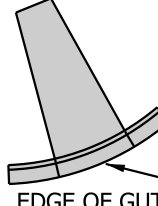
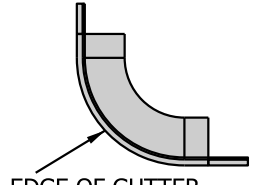
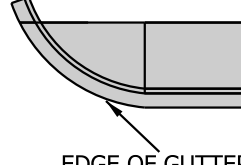
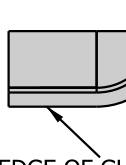
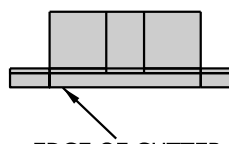
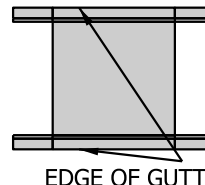
<p>CURB RAMP TYPE A</p>  <p>EDGE OF GUTTER</p>	<p>CURB RAMP TYPE B</p>  <p>EDGE OF GUTTER</p>	<p>CURB RAMP TYPE C</p>  <p>EDGE OF GUTTER</p>	<p>CURB RAMP TYPE D</p>  <p>EDGE OF GUTTER</p>	<p>CURB RAMP TYPE E</p>  <p>EDGE OF GUTTER</p>
<p>CURB RAMP TYPE F</p>  <p>EDGE OF GUTTER</p>	<p>CURB RAMP TYPE G</p>  <p>EDGE OF GUTTER</p>	<p>CURB RAMP TYPE H</p>  <p>EDGE OF GUTTER</p>	<p>CURB RAMP TYPE K</p>  <p>EDGE OF GUTTER</p>	<p>CURB RAMP TYPE L</p>  <p>EDGE OF GUTTER</p>

TYPICAL RAMP CONSTRUCTION

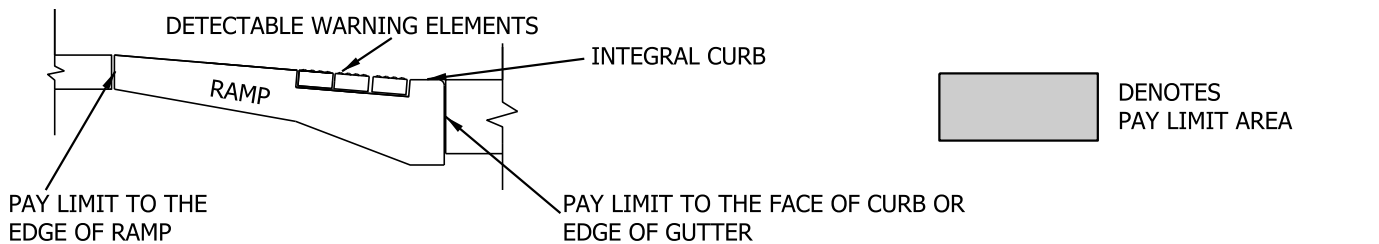

DETAIL SHEET - HMA PATCHING DETAILS

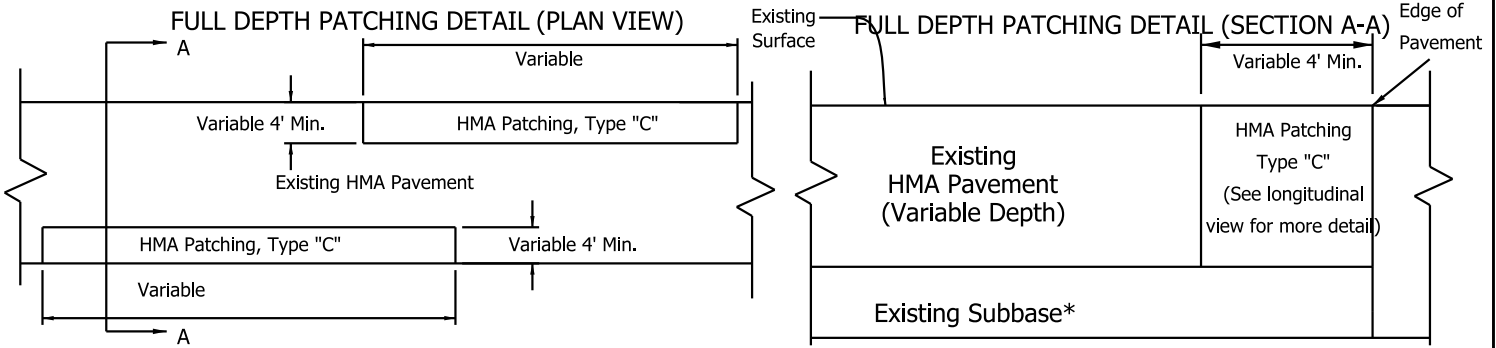

FULL DEPTH PATCHING DETAIL (LONGITUDINAL VIEW)

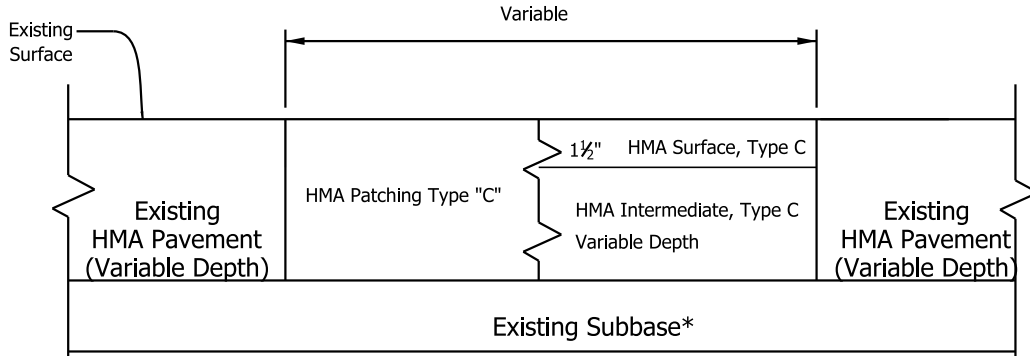

FULL DEPTH PATCHING DETAIL (COMPOSITE AT PALMYRA) (LONGITUDINAL VIEW)

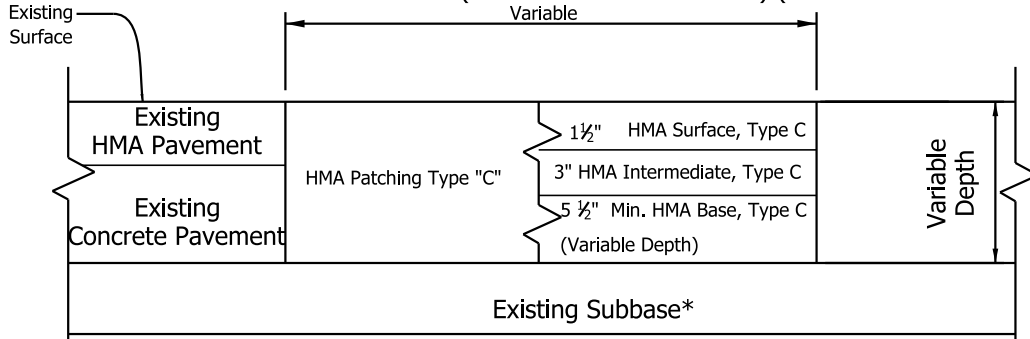

HMA PARTIAL DEPTH PATCHING DETAIL - PROFILE VIEW

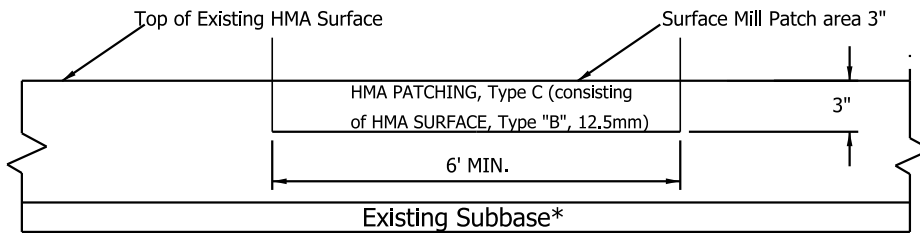

NOTES:

- * IF EXISTING SUBBASE IS EXISTING CONCRETE DO NO DISTURB UNLESS NOTED
- 1. ACTUAL LOCATIONS OF PATCHING WILL BE DETERMINED BY PROJECT ENGINEER.
- 2. HMA PATCHING, TYPE C FOR FULL DEPTH PATCHING (COMPOSITE AT PALMYRA) SHALL CONSIST OF 1 1/2\" HMA, SURFACE, TYPE C OVER 3\" HMA, INTERMEDIATE, TYPE C OVER 5 1/2\" HMA BASE, TYPE C. (MIN. 10\" THICKNESS REQUIRED FOR FULL DEPTH PATCH). A QUANTITY OF PAVEMENT REMOVAL WILL BE PROVIDE TO REMOVE THE CONCRETE PORTION OF THE COMPOSITE AREA.
- 3. NEAR THE RAILROAD CROSSING NO PATCHING SHALL BE PLACED WITHIN 50' OF THE CROSSING
- 4. AN UNDISTRIBUTED QUANTITY OF 200 TONS FOR HMA PATCHING SHALL BE PROVIDED UNDISTRIBUTED TO BE PLACED AT THE DISCRETION OF THE PROJECT ENGINEER.

PAVEMENT MARKINGS TABLE

MAINLINE AND APPROACHES - S.R. 135

Beg. Station	End Station	Description	Quantity	Unit
10+00	305+90	Edge Line, White Solid 4", Paint (Both Sides)	59180	Lft.
10+00	12+80	Southbound Centerline, White Broken 4", Paint	280	Lft.
10+00	24+50	Northbound Centerline, White Broken 4", Paint	1450	Lft.
10+00	26+00	Edge Line Median, Yellow Solid 4", Paint (Both Sides)	3200	Lft.
11+00		Detector Housing	1	Ea.
11+00		Traffic Detection Loops	2	Ea.
12+80	13+58	Southbound Lane Line, White Solid 4", Paint	78	Lft.
12+80	14+30	Northbound Lane Line, White Solid 4", Paint	150	Lft.
13+18		Trans. Marking, Thermo., Lane Indication Arrow	1	Ea.
13+58		Trans. Marking, Thermo., Word "ONLY"	1	Ea.
13+58	14+70	Gore Striping Line White Solid 8", Thermo.	400	Lft.
13+58	14+70	Trans. Gore Striping, Line White Solid 24", Thermo.	250	Lft.
13+95		Trans. Marking, Thermo., Lane Indication Arrow	1	Ea.
14+07		Detector Housing	1	Ea.
14+07		Traffic Detection Loops	4	Ea.
14+30		Trans. Marking for Stop Bar, Line White Solid 24", Thermo.	36	Lft.
14+80		Trans. Marking for Stop Bar, Line White Solid 24", Thermo. (Lt.)	12	Lft.
14+80		Trans. Marking, Thermo., Lane Indication Arrow (Lt.)	2	Ea.
14+80		Trans. Marking, Thermo., Word "ONLY" (Lt.)	1	Ea.
15+25	19+05	Gore Striping Line White Solid 8", Thermo.	850	Lft.
15+25	19+05	Trans. Gore Striping, Line White Solid 24", Thermo.	400	Lft.
15+35		Trans. Marking for Stop Bar, Line White Solid 24", Thermo.	12	Lft.
17+80	25+70	Trans. Gore Striping, Line White Solid 24", Thermo.	800	Lft.
17+80	25+70	Trans. Marking for Stop Bar, Line White Solid 24", Thermo.	400	Lft.
19+90		Trans. Marking, Thermo., Lane Indication Arrow	1	Ea.
22+70		Detector Housing	1	Ea.
22+70		Traffic Detection Loops	2	Ea.
24+50		Trans. Marking, Thermo., Lane Indication Arrow	1	Ea.
24+50	26+00	Northbound Lane Line, White Solid 4", Paint (2 Lanes)	150	Lft.
24+90		Trans. Marking, Thermo., Lane Indication Arrow	2	Ea.
25+30		Trans. Marking, Thermo., Word "ONLY"	2	Ea.
25+70		Trans. Marking, Thermo., Lane Indication Arrow	2	Ea.
26+00		Trans. Marking for Stop Bar, Line White Solid 24", Thermo.	36	Lft.
26+45		Trans. Marking for Stop Bar, Line White Solid 24", Thermo. (Lt.)	25	Lft.
26+45		Trans. Marking for Stop Bar, Line White Solid 24", Thermo. (Rt.)	25	Lft.
27+00		Trans. Marking for Stop Bar, Line White Solid 24", Thermo.	36	Lft.
27+00	28+55	Southbound Lane Line, White Solid 4", Paint (2 Lanes)	310	Lft.
27+30		Detector Housing	1	Ea.
27+30		Traffic Detection Loops	4	Ea.
27+40		Trans. Marking, Thermo., Lane Indication Arrow	2	Ea.
27+75		Trans. Marking, Thermo., Word "ONLY"	2	Ea.
28+15		Trans. Marking, Thermo., Lane Indication Arrow	2	Ea.

PAVEMENT MARKINGS TABLE (CONTINUED)

MAINLINE AND APPROACHES - S.R. 135

Beg. Station	End Station	Description	Quantity	Unit
28+15	31+35	Gore Striping Line Yellow Solid 8", Thermo.	600	Lft.
28+15	31+35	Trans. Gore Striping, Line Yellow Solid 24", Thermo.	100	Lft.
28+55		Trans. Marking, Thermo., Lane Indication Arrow	1	Ea.
31+35		Trans. Marking, Thermo., RXR	1	Ea.
33+00		Trans. Marking for Stop Bar, Line White Solid 24", Thermo.	12	Lft.
34+00		Trans. Marking for Stop Bar, Line White Solid 24", Thermo.	12	Lft.
39+80		Trans. Marking, Thermo., RXR	1	Ea.
52+45	55+40	Northbound Lane Line, White Solid 4", Paint	295	Lft.
108+51		Trans. Marking, Thermo., RXR	1	Ea.
115+50		Trans. Marking for Stop Bar, Line White Solid 24", Thermo.	12	Lft.
118+15		Trans. Marking for Stop Bar, Line White Solid 24", Thermo.	12	Lft.
125+40		Trans. Marking, Thermo., RXR	1	Ea.
141+75	148+90	Northbound Lane Line, White Solid 4", Paint	715	Lft.
141+75		Trans. Marking, Thermo., Word "ONLY"	1	Ea.
142+15		Trans. Marking, Thermo., Lane Indication Arrow	1	Ea.
147+85		Trans. Marking, Thermo., Word "ONLY"	1	Ea.
148+25		Trans. Marking, Thermo., Lane Indication Arrow	1	Ea.
148+90	152+55	Southbound Lane Line, White Solid 4", Paint	365	Lft.
149+95		Monument, Type B (Do Not Disturb)		
149+95		Trans. Marking for Stop Bar, Line White Solid 24", Thermo. (Rt.)	55	Lft.
305+90	308+65	Gore Striping Line Yellow Solid 8", Thermo.	800	Lft.
305+90	308+65	Trans. Gore Striping, Line Yellow Solid 24", Thermo.	200	Lft.
307+19		Detector Housing	1	Ea.
307+19		Traffic Detection Loops	2	Ea.
307+50		Monument, Type B (Do Not Disturb)		
308+65	310+15	Northbound Lane Line, White Solid 4", Paint	150	Lft.
308+65		Monument, Type B (Do Not Disturb)		
308+65		Trans. Marking, Thermo., Word "ONLY"	1	Ea.
309+04		Trans. Marking, Thermo., Lane Indication Arrow	1	Ea.
309+40		Trans. Marking, Thermo., Word "ONLY"	1	Ea.
309+90		Trans. Marking, Thermo., Lane Indication Arrow	1	Ea.
309+95		Detector Housing	2	Ea.
309+95		Traffic Detection Loops	8	Ea.
310+15		Trans. Marking for Stop Bar, Line White Solid 24", Thermo.	24	Lft.
310+75		Trans. Marking for Stop Bar, Line White Solid 24", Thermo. (Lt.)	26	Lft.
310+75		Trans. Marking for Stop Bar, Line White Solid 24", Thermo. (Rt.)	26	Lft.
310+75		Trans. Marking, Thermo., Lane Indication Arrow (Lt.)	1	Ea.
310+75		Trans. Marking, Thermo., Lane Indication Arrow (Rt.)	1	Ea.
310+75		Detector Housing (Lt.)	2	Ea.
310+75		Traffic Detection Loops (Lt.)	8	Ea.
310+75		Detector Housing (Rt.)	2	Ea.
310+75		Traffic Detection Loops (Rt.)	8	Ea.

CURB RAMP TABLE

CURB RAMP TABLE

Curb Ramp Description	Number	Size (sys)	Area (sys)
Type A	0.00	11.10	0.00
Type B	0.00	30.60	0.00
Type C	0.00	3.50	0.00
Type D	0.00	3.50	0.00
Type E	0.00	10.70	0.00
Type F	0.00	23.30	0.00
Type G	13.00	6.00	78.00
Type H	0.00	7.70	0.00
Type K	0.00	11.10	0.00
Type L	0.00	9.30	0.00

TOTAL = 78.00

*** NOTE: IF SITE INFEASIBILITIES OR VARYING FIELD CONDITIONS EXIST FOR CONSTRUCTING A PLANNED STANDARD CURB RAMP, USE OF A DIFFERENT STANDARD CURB RAMP SHALL BE AS DIRECTED BY THE PROJECT ENGINEER/ SUPERVISOR. CURB RAMP TRANSITIONS WILL BE PROVIDED FOR DRIVES & ENTRANCES. UNDISTRIBUTED ITEMS OF SIDEWALK, CURB & SODDING WILL BE PROVIDED FOR CONSTRUCTION OF RAMPS. UNDISTRIBUTED QUA. ARE AS FOLLOWS: SIDEWALK REMOVE AND REPLACE - 10 SYS., CURB, REMOVE AND REPLACE--10 LFT., SODDING -- 10 SYS.**

**** NOTE: SEE CURB RAMP PAY LIMIT DETAIL FOR LIMITS OF PAYMENT FOR TYPICAL CURB RAMPS FROM STD.**

DESCRIPTION	QUA.	UNIT
CURB RAMP, CONCRETE, (TYPE) G	78	SYS.
SIDEWALK, CONCRETE, REMOVE (UNDISTRIBUTED)	10	SYS.
CURB, CONCRETE, REMOVE (UNDISTRIBUTED)	10	LFT.
SIDEWALK, CONCRETE (UNDISTRIBUTED)	10	SYS.
CURB, CONCRETE, A (UNDISTRIBUTED)	10	LFT.
SODDING (UNDISTRIBUTED)	10	SYS.

PAVEMENT MARKINGS TABLE TOTALS

Description	Quantity	Unit
Transverse Markings, Thermoplastic, Stop Bar, White, 24"	275	Lft.
Line, Paint, Solid, Yellow, 4"	30,677	Lft.
Line, Paint, Broken, Yellow, 4"	5,506	Lft.
Line, Paint, Solid, White, 4"	64,062	Lft.
Line, Paint, Broken, White, 4"	1,730	Lft.
Line, Thermoplastic, Solid, White, 8"	2,050	Lft.
Line, Thermoplastic, Solid, Yellow, 8"	2,960	Lft.
Transverse Markings, Thermoplastic, Yellow for Crosshatch, 24"	600	Lft.
Transverse Markings, Thermoplastic, White for Crosshatch, 24"	662	Lft.
Snowplowable Raised Pavement Marker, Remove	630	Ea.
Transverse Markings, Thermoplastic, Lane Indication Arrow	20	Ea.
Transverse Markings, Thermoplastic, Word "ONLY"	13	Ea.
Transverse Markings, Thermoplastic, RXR	4	Ea.
Detector Housing, Single	14	Ea.
Traffic Detection Loops	48	Ea.
Sawcut for Roadway Loop and Sealant	1,920	Lft.
Signal Cable, Roadway Loop, 1C/14 Ga.	6,000	Lft.
Signal Cable, 2C/16 Ga., Shielded	600	Lft.
Transverse Markings, Thermoplastic, White for Crosswalk, 8"	390	Lft.
Temporary Pavement Markings, Removable, 4"	4,000	Lft.

QUANTITY TABLES

QUANTITIES FOR MILLING AND RESURFACING ROADWAY

DESCRIPTION	MILLING, ASPHALT, 1.5" (yd ²)	MILLING, ASPHALT, SCARIFICATION (yd ²)	165 LBS/YD ² QC/QA HMA, 3, 70, SURFACE, 9.5 mm (TONS)	ULTRATHIN BONDED WEARING COURSE, 9.5 mm (yd ²)	JOINT ADHESIVE (Lft.)	TACK COAT (TONS)
S.R. 135 and I-64 Detail Area		14,500.0		14,500.0		
Mainline		83,931.3		83,931.3		
Left Shoulder		6,322.2		6,322.2		
Right Shoulder		6,322.2		6,322.2		
S.R. 135 Palymra Detail Mainline	9,155.6		755.3		2,150.0	2.5
S.R. 135 Palymra Detail Left Shoulder	50.0		4.1		2,150.0	0.0
S.R. 135 Palymra Detail Right Shoulder	200.0		16.5		2,150.0	0.1
S.R. 135 and U.S. 150 Intersection	800.0		66.0		400.0	0.2
TOTALS	10,206	111,076	842	111,076	6,850	3

MISCELLANEOUS ITEMS AND PAVEMENT QUANTITIES TOTALS

DESCRIPTION	QUA.	UNIT
Construction Sign, Type A	55	Ea.
Construction Sign, Type C	10	Ea.
Milling, Asphalt, 1.5"	10,206	Sys.
Milling, Asphalt, Scarification	111,076	Sys.
QC/QA HMA 3, 70, Surface, 9.5mm	842	Tons
Ultrathin Bonded Wearing Course, 9.5 mm	111,076	Sys.
Asphalt for Tack Coat	3	Tons
HMA for Patching, Type C (Undistributed)	200	Tons
Milled HMA Corrugations	86,045	Lft.
Joint Adhesive	6,850	Lft.
Liquid Asphalt Sealant	6,850	Lft.
Milling, Asphalt, Approach (For U.S. 150 Intersection)	3,000	Sys.
HMA for Approaches, Type C (For U.S. 150 Intersection)	250	Tons